

POWERTIP TECH. CORP.

DISPLAY DEVICES FOR BETTER ELECTRONIC DESIGN

液晶之友 电话: 020-33819057
Http://www.lcdfriends.com

Specification For Approval

Customer : _____

Model Type : LCD MODULE

Sample Code : PS320240FRC-DNNC01

Mass Production Code : _____

Edition : 0

Customer Sign	Sales Sign	Checked By (QA)	Approved By	Prepared By

Revision Record

Date(y/m/d)	Rev.	Description	Note	Page
2003/3/12	0	New sample		

Contents

1. SPECIFICATIONS

- 1.1 Features
- 1.2 Mechanical Specifications
- 1.3 Absolute Maximum Ratings
- 1.4 DC Electrical Characteristics
- 1.5 Optical Characteristics
- 1.6 Backlight Characteristics

2. MODULE STRUCTURE

- 2.1 Counter Drawing
- 2.2 Interface Pin Description
- 1.3 Timing Characteristics
- 1.4 Display pattern

3. QUALITY ASSURANCE SYSTEM

- 3.1 Quality Assurance Flow Chart
- 3.2 Inspection Specification

4. RELIABILITY TEST

- 4.1 Reliability Test Condition

5. PRECAUTION RELATING PRODUCT HANDLING

- 5.1 Safety
- 5.2 Handling
- 5.3 Storage
- 5.4 Terms of Warranty



1. SPECIFICATIONS

1.1 Features

Item	Standard Value
Display Type	320 RGB* 240 Dots
LCD Type	FSTN, Transmissive, Negative, Normal Temp.
Driver Type	LCD Module : 1/240 Duty, 1/16.5 Bias
Viewing Direction	6 O' clock
Backlight	CCFL B/L
Weight	180 g
Other	8 bit parallel data input

1.2 Mechanical Specifications

Item	Standard Value	Unit
Outline Dimension	156.0 (L) * 114.8 (w) * 8.5 (H)(Max)	mm
Viewing Area	118.18 (L) * 89.38 (w)	mm
Active Area	115.18 (L) * 86.38 (w)	mm
Dot Size	0.33 (L) * 0.09 (w)	mm
Dot Pitch	0.36 (L) * 0.12 (w)	mm

1.3 Absolute Maximum Ratings

Item	Symbol	Condition	Min.	Max.	Unit
Power Supply Voltage	V_{DD}	$V_{SS} = 0V$	-0.3	6.5	V
	V_{LCD}		0	30	V
Input Voltage	V_{IN}	-	-0.3	V_{DD}	V
Operating Temperature	T_{OP}	-	0	50	°C
Storage Temperature.	T_{ST}	-	-20	60	°C
Humidity	H_D	Ta 50°C	20	85	%RH



POWERTIP TECHNOLOGY CORPORATION

DISPLAY DEVICES FOR BETTER ELECTRONIC DESIGN

1.4 DC Electrical Characteristics

$$V_{DD} = 5.0 \text{ V}, V_{SS} = 0 \text{ V}, T_a = 25^\circ \text{C}$$

Item	Symbol	Condition	Min.	Typ.	Max.	Unit
Logic Supply Voltage	V_{DD}	-	2.7	5.0	5.5	V
“H” Input Voltage	V_{IH}	-	$0.8V_{DD}$	-	V_{DD}	V
“L” Input Voltage	V_{IL}	-	V_{SS}	-	$0.2 V_{DD}$	V
Supply Current	I_{DD}	$V_{DD} = 5 \text{ V}, V_{LCD} - V_{SS} = 25.3 \text{ V}, \text{Frame} = 70 \text{ Hz}$	-	0.7	4.0	mA
	I_{LCD}		-	2.7	11.0	
LCD Driver Voltage	V_{OP}	$V_{LCD} - V_{SS} (0^\circ \text{C})$	25.8	26.3	26.8	V
		$V_{LCD} - V_{SS} (25^\circ \text{C})$	24.8	25.3	25.8	
		$V_{LCD} - V_{SS} (50^\circ \text{C})$	23.9	24.4	24.9	

1.5 Optical Characteristics

$$\text{LCD Panel : } 1/240 \text{ Duty}, 1/16.5 \text{ Bias}, V_{OP} = 23.0 \text{ V}, T_a = 25^\circ \text{C}$$

Item	Symbol	Conditions	Min.	Typ.	Max.	Reference	
View Angle	θ	$C \geq 2.0, \varnothing = 0^\circ$	-41	-	21	Notes 1 & 2	
Contrast Ratio	C	$\theta = 0^\circ, \varnothing = 0^\circ$	-	12.8	-	Note 3	
Response Time(rise)	t_r	$\theta = 0^\circ, \varnothing = 0^\circ$	-	108	-	Note 4	
Response Time(fall)	t_f	$\theta = 0^\circ, \varnothing = 0^\circ$	-	502	-	Note 4	
Color Tone (CIE Coordinate)	R	X	$\theta = 0^\circ, \varnothing = 0^\circ$	0.47	0.52	0.57	
		Y		0.32	0.37	0.42	
	G	X		0.28	0.33	0.38	
		Y		0.44	0.49	0.54	
	B	X		0.14	0.19	0.24	
		Y		0.15	0.20	0.25	
	W	X		0.28	0.33	0.38	
		Y		0.29	0.34	0.39	



POWERTIP TECHNOLOGY CORPORATION

DISPLAY DEVICES FOR BETTER ELECTRONIC DESIGN

Note 1: Definition of angles θ and \varnothing

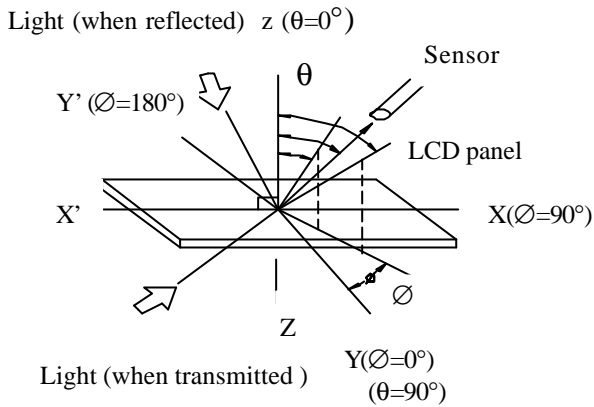

Note 2: Definition of viewing angles θ_1 and θ_2

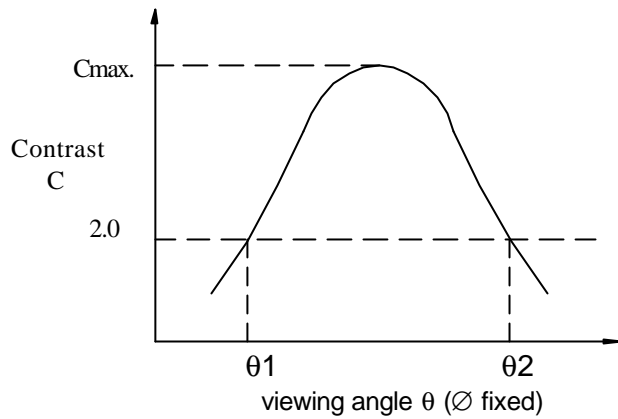

Note : Optimum viewing angle with the naked eye and viewing angle θ at C_{max} . Above are not always the same

Note 3: Definition of contrast C

$$C = \frac{\text{Brightness of unselected dot (B2)}}{\text{Brightness of selected dot (B1)}}$$

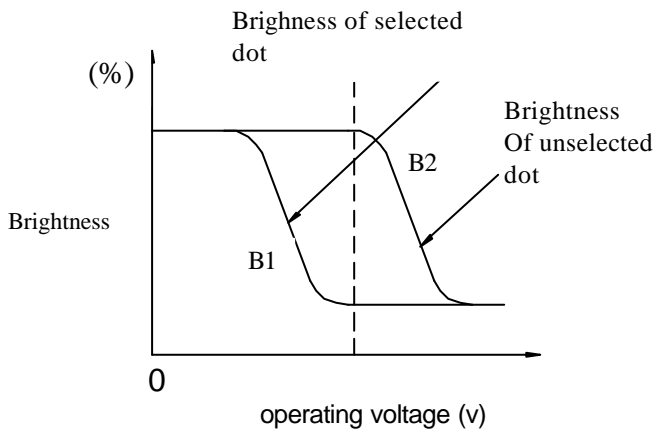

Note 4: Definition of response time

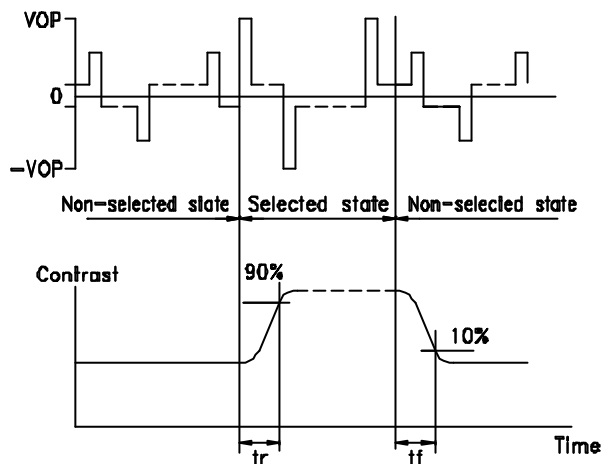

Note: Measured with a transmissive LCD panel which is displayed 1 cm^2

V_{OPR} : Operating voltage f_{FRM} : Frame frequency
 t_r : Response time (rise) t_f : Response time (fall)

1.6 Backlight Characteristics

LCD Module with CCFL Backlight

Electrical Characteristics

Item	Spec	Unit	Condition
Start Voltage	500	Vrms	25°C
Tube Current	5	mA	
Life Time (IL= 5 mA)	20000	Hr	
Driver Frequency	50	KHz	
Operating Temperature	0 ~ 50	°C	
Storage Temperature	-20 ~ 60	°C	5~90% RH

CCFL B/L Pin Assignment

Item	SYMBOL	Min.	Typ.	Max.	Unit	REMARK
FREQUENCY	F	40	50	60	KHZ	
DISCHARGING TUBE CURRENT	I _{rms}	4.5	5.0	-	mArms	
DISCHARGING TUBE VOLTAGE	VL	-	500	-	Vrms	

FL Connector : BHR-03VS-1 (JST)



POWERTIP TECHNOLOGY CORPORATION

DISPLAY DEVICES FOR BETTER ELECTRONIC DESIGN

2. MODULE STRUCTURE

2.1 Counter Drawing

* See Appendix

2.2 Interface Pin Description

PIN	SIGNAL NAME	Level	DESCRIPTION
1	FLM	H/L	Signal input
2	CL1	H - > L	Display data latch Pulse
3	CL2	H - > L	Display data shift Pulse
4	/DISPOFF	H/L	Enable Driver On (H) or Off (L)
5	V _{DD}	-	Logic system power supply pin
6	V _{SS}	-	Signal Ground (0V)
7	V _{LCD}	-	Power supply for LCD (+V)
8~15	DB0~DB7	H/L	Display data

Note : In our suggestion that FLM =70Hz , If there are some flicker and ripple phenomenon. Please setting the frame frequency in your set.

Interface	Pin	Signal	Function
CCFL Back Light	1	HV+	Power supply for CCFL back light (AC Signal)
	2~3	NC	No connection
	4	HV-	Power supply for CCFL back light (AC Signal)

FL Connector : BHR-03VS-1(JST)

Contrast Adjust

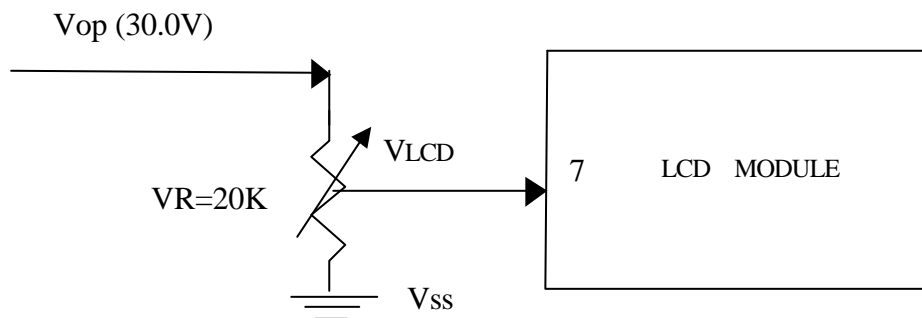

POWERTIP TECHNOLOGY CORPORATION
DISPLAY DEVICES FOR BETTER ELECTRONIC DESIGN

2.3 Timing Characteristics

Interface Timing chart

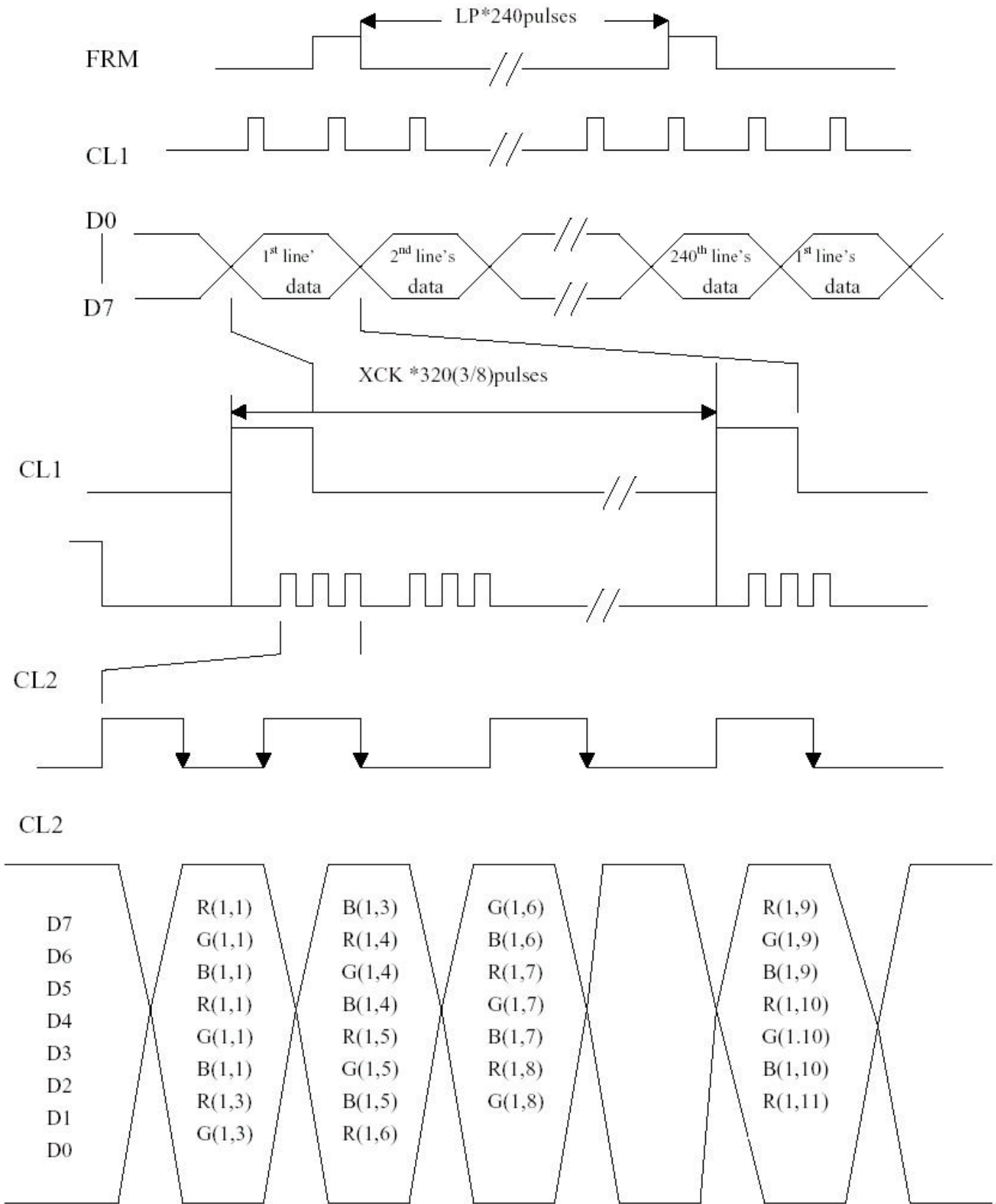

Common and Segment Interface Timing Chart

ITEM	symbol	Test Condition	Min.	Typ.	Max.	Units
Clock Cycle	tC	Fig.1	500			ns
SCP Pulse Width	tSWH,tSWL	Fig.1	240			ns
Data Set Up Time	tDSU	Fig.1 & 2	240			ns
Data Hold Time	tDHD	Fig.1 & 2	240			ns
SCP Rise/Fall Time	tr,tf	Fig.1 & 2			50	ns
LP Rise Time	tLRP	Fig. 1	240			ns
LP Fall Time	tLFP	Fig. 1	240			ns
LP Pulse Width	tLW	Fig. 1	240			ns
SCP To LP Delay Time	tSL	Fig. 1	50			ns
LP To SCP Delay Time	tLS	Fig. 1	100			ns
LP "H" Pulse Width	tCWH	Fig. 2	40			ns
LP "L" Pulse Width	tCWL	Fig. 2	170			ns

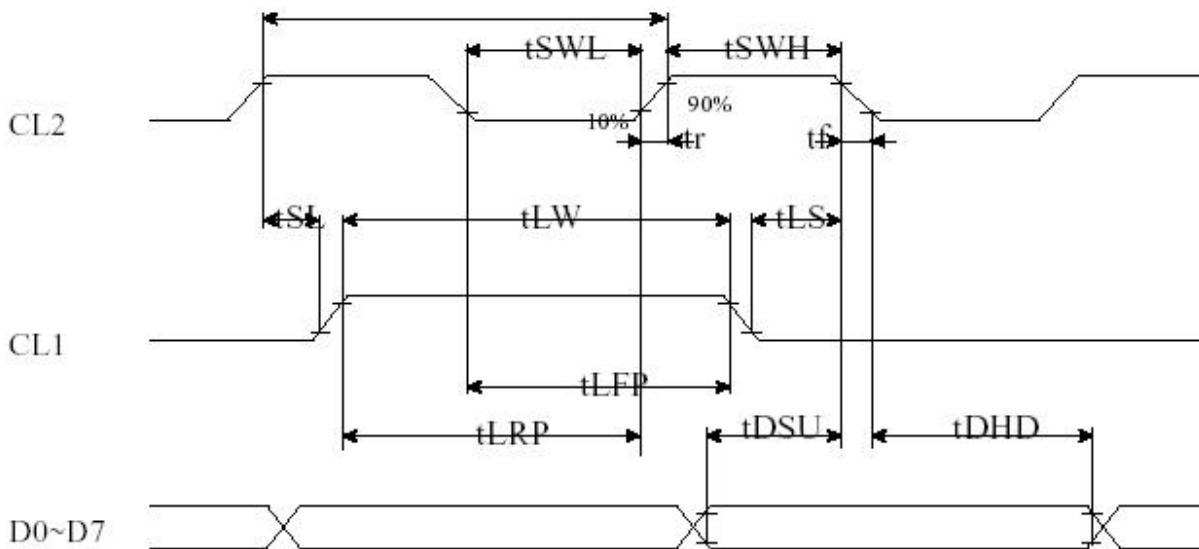

Fig 1. SEGMENT TIMING

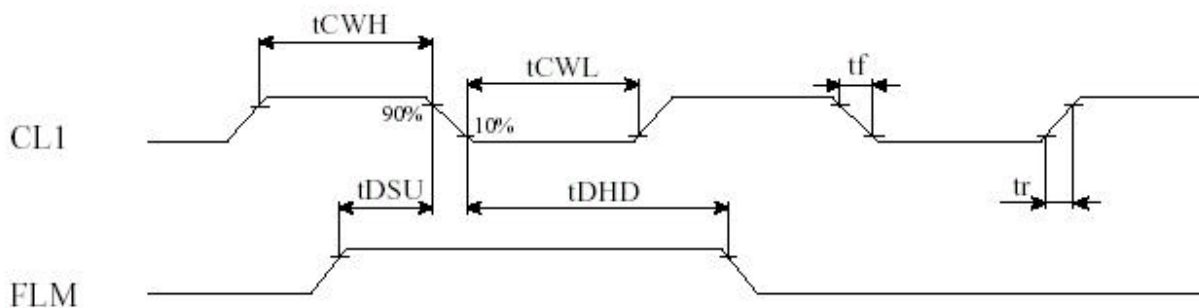
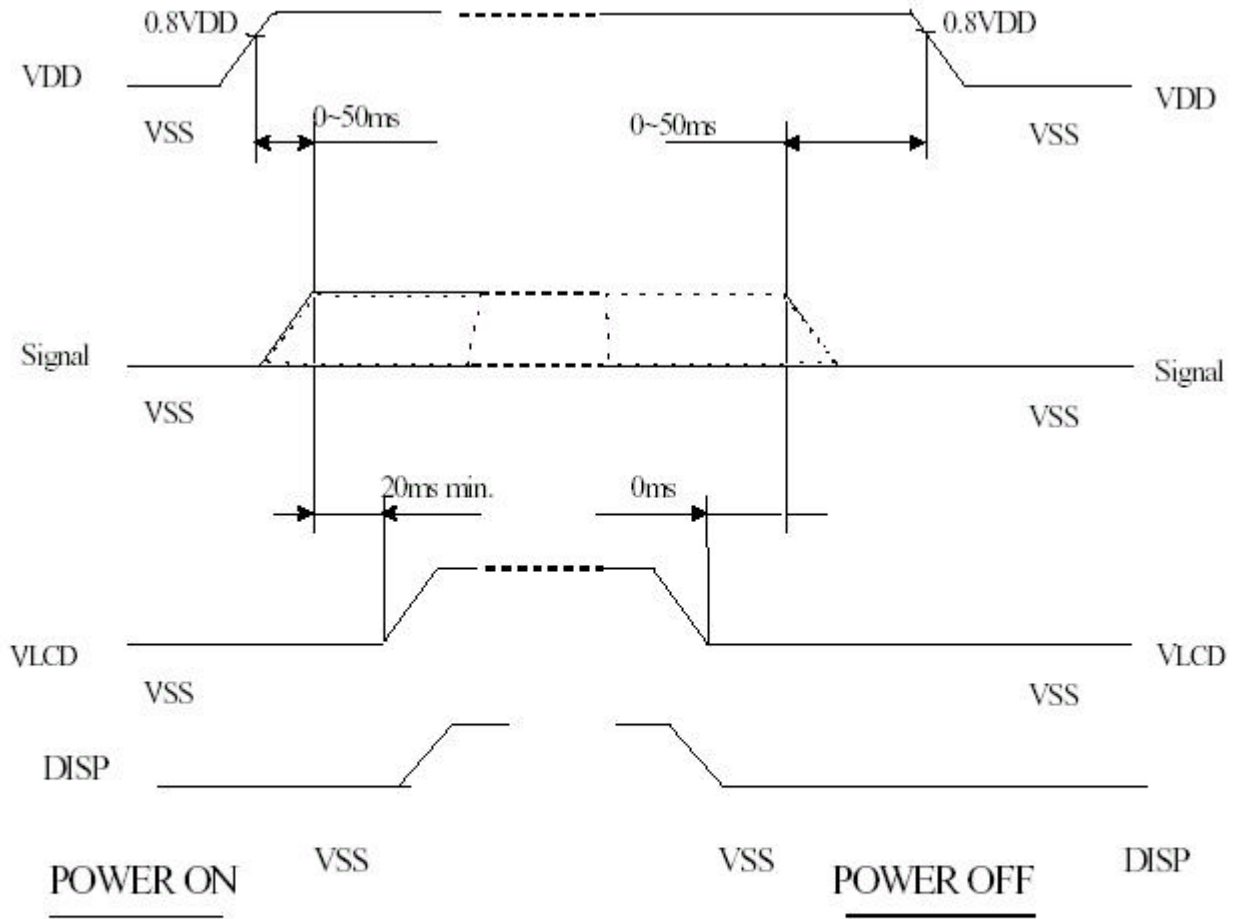

Fig 2 COMMON TIMING

Power On/Off Timing



POWERTIP TECHNOLOGY CORPORATION
 DISPLAY DEVICES FOR BETTER ELECTRONIC DESIGN



The missing pixels may occur when the LCM is driven beyond above power interface timing sequence.

2-4 Display Pattern

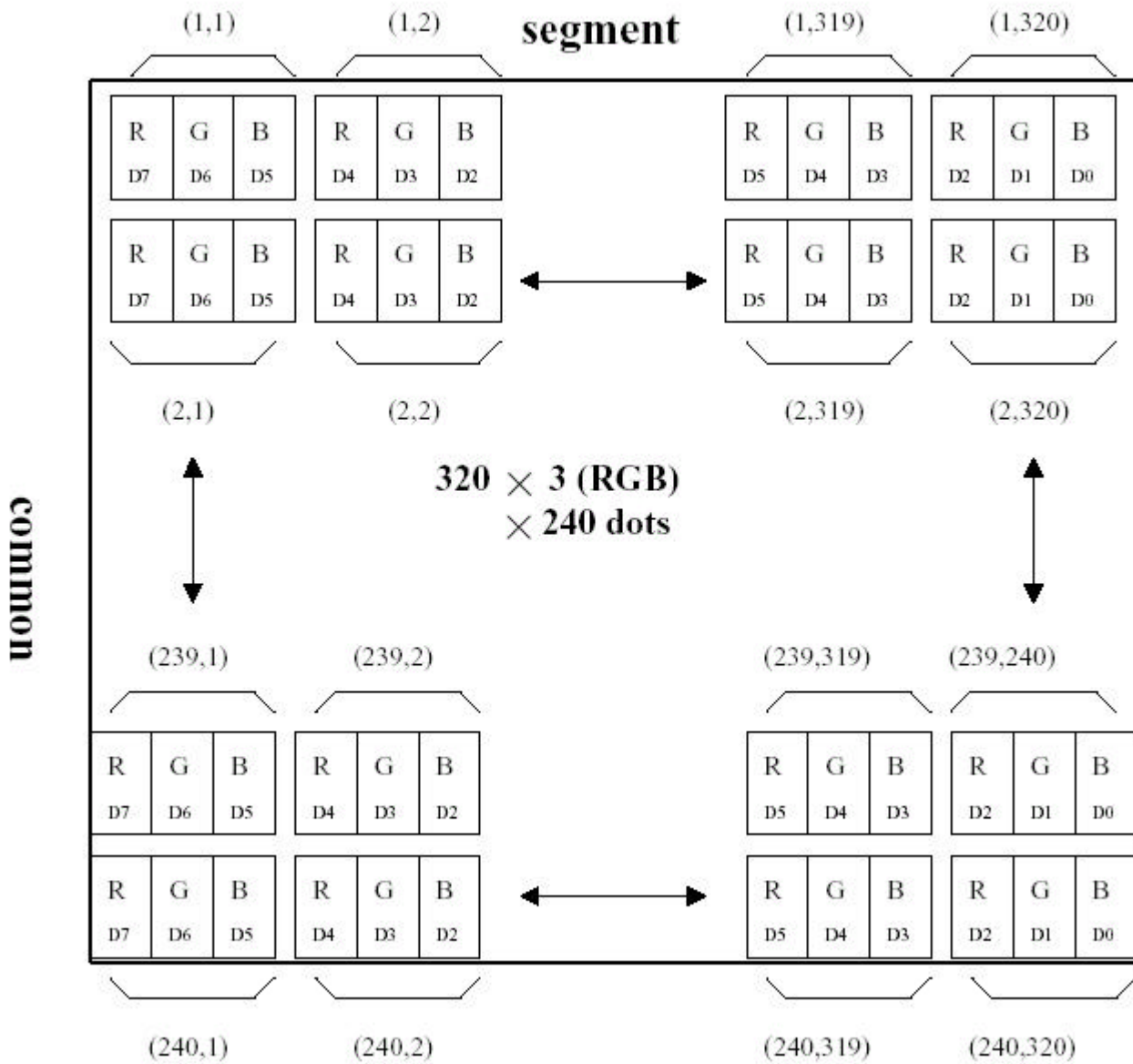

POWERTIP TECHNOLOGY CORPORATION

DISPLAY DEVICES FOR BETTER ELECTRONIC DESIGN

3. QUALITY ASSURANCE SYSTEM

3.1 Quality Assurance Flow Chart

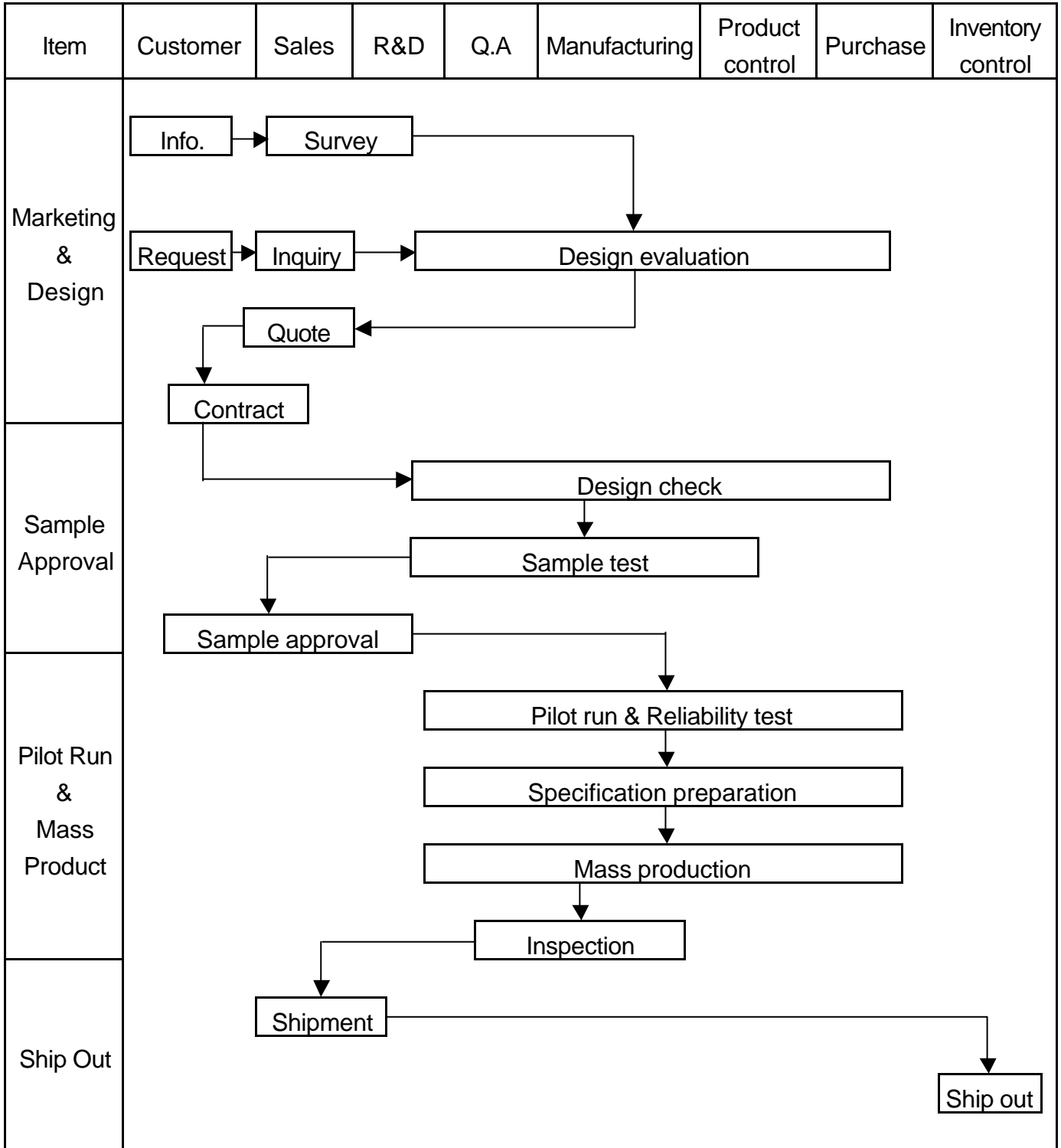

<p>Sales Service</p>	<pre> graph TD Info[Info.] --> Claim[Claim] Claim --> Failure[Failure analysis] Failure --> Report[Analysis report] Failure --> Action[Corrective action] Action --> Tracking[Tracking] </pre>
<p>Q.A Activity</p>	<ol style="list-style-type: none"> 1. ISO 9001 Maintenance Activities 2. Process improvement proposal 3. Equipment calibration 4. Education And Training Activities 5. Standardization Management

3.2 Inspection Specification

Inspection Standard : MIL-STD-105E Table Normal Inspection Single Sampling Level 。

Equipment : Gauge、MIL-STD、Powertip Tester、Sample。

IQC Defect Level : Major Defect AQL 0.65; Minor Defect AQL 1.0。

FQC Defect Level : 100% Inspection。

OUT Going Defect Level : Sampling。

Specification :

NO	Item	Specification	Judge	Level
1	Part Number	Inconsistent with the P/N on the flow chart of production	N.G.	Major
2	Quantity	Inconsistent Q'TY with the flow chart of production	N.G.	Major
3	Electronic characteristics A=(L + W) ÷ 2	Display short	N.G.	Major
		Missing line	N.G.	Major
		Dot missing A > 1/2 Dot size	N.G.	Major
		No function	N.G.	Major
		Out put data error	N.G.	Major
4	Appearance A=(L + W) ÷ 2	Material difference with flow chart	N.G.	Major
		LCD Assembled in opposite direction	N.G.	Major
		Bezel assembled in opposite direction	N.G.	Major
		Shadow within LCD V./A + 1.0 mm	N.G.	Major
	Dirty particle (Include scratch、bubble)	Dirty particle A > 0.4 mm	N.G.	Minor
		Dirty particle length > 3.0mm And 0.01mm < Width 0.05mm (Width > 0.05mm Measure by area)	N.G.	Minor
		Without protective film	N.G.	Minor
		Conductive rubber over bezel	N.G.	Minor
5	PCB Appearance A=(L + W) ÷ 2	Burned PCB	N.G.	Major
		Green paint stripped & visible circuit A > 1.0mm (Finish coat not counted in)	N.G.	Minor
		A particle across the circuit	N.G.	Minor
		Circuit split > 1/2 Circuit width	N.G.	Minor
		Any circuit risen	N.G.	Minor
		0.2mm < Tin ball area A 0.4mm And Q'TY > 4 Pieces	N.G.	Minor
		Tin ball area A > 0.4mm	N.G.	Minor



POWERTIP TECHNOLOGY CORPORATION

DISPLAY DEVICES FOR BETTER ELECTRONIC DESIGN

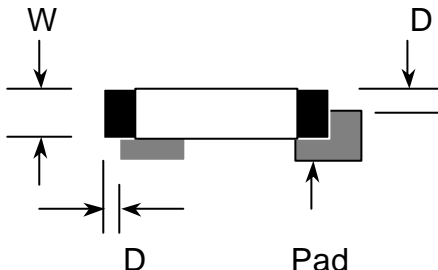
NO	Item	Specification	Judge	Level
6	Molding appearance $A=(L+W) \div 2$	Too soft : Shape by touch changed	N.G.	Major
		Insufficient epoxy : IC circuit or IC pad visible	N.G.	Minor
		Excessive epoxy : Diameter > 20mm Or High > 2.5mm	N.G.	Minor
		Pin hole through to IC and A > 0.2mm	N.G.	Minor
7	Bezel appearance $A=(L+W) \div 2$	Angle between frame and TAB > 45 +10	N.G.	Minor
		Electroplate strip A > 1.0mm (Top view only)	N.G.	Minor
		Rust (Top view only)	N.G.	Minor
		Crack	N.G.	Minor
8	Backlight electric characteristics $A=(L+W) \div 2$	Error backlight color	N.G.	Major
		No function	N.G.	Major
		Any LED dot no function	N.G.	Major
		PIN soldering without tin A > 1/2 solder pad	N.G.	Minor
		Solder PIN high > 1.5mm	N.G.	Minor
9	LCD Appearance $A=(L+W) \div 2$	Polarize rise over V/A	N.G.	Minor
10	Assembly parts $A=(L+W) \div 2$	Components mark unclearly	N.G.	Minor
		Components' distance more than 0.7mm from the PCB	N.G.	Minor
		Error position ,not in center $D > 1/4W$	N.G.	Minor
				
		Non- solder area > Twice solder area	N.G.	Minor
		Flux area A > 1/4 solder area	N.G.	Minor
		Component broken	N.G.	Minor



4. RELIABILITY TEST

4.1 Reliability Test Condition

NO	Item	Test Condition		Applicable Standard
1	High Temperature Storage	Storage At 80 ± 2 96~100 hrs Surrounding Temperature , Then Storage At Normal Condition 4hrs.		MIL-202E
2	Low Temperature Storage	Storage At -30 ± 2 96~100 hrs Surrounding Temperature, Then Storage At Normal Condition 4hrs.		MIL-202E
3	High Temperature Humidity Storage	1.Storage 96~100 hrs 60 ± 2 , 90~95%RH Surrounding Temperature, Then Storage At Normal Condition 4hrs .(Polarizer may fail in this environment). or 2.Storage 96~100 hrs 40 ± 2 , 90~95%RH Surrounding Temperature, Then Storage At Normal Condition 4 hrs.		MIL-202E
4	Temperature Cycling	-20 25 70 25 (30Mins) (5Mins) (30Mins) (5Mins) 10 Cycle		MIL-202E
5	Vibration	10~55Hz (1 Minute) 1.5mm X,Y And Z Direction * (Each 2hrs)		MIL-202E
6	Drop Test	Packing Weight (Kg)	Drop High (Cm)	MIL-810E
		0 ~ 45.4	122	
		45.4 ~ 90.8	76	
		90.8 ~ 454	61	
		Over 454	46	



POWERTIP TECHNOLOGY CORPORATION

DISPLAY DEVICES FOR BETTER ELECTRONIC DESIGN

5. PRECAUTION RELATING PRODUCT HANDLING

5.1 SAFETY

- 5.1.1 If the LCD panel breaks , be careful not to get the liquid crystal to touch your skin.
- 5.1.2 If the liquid crystal touches your skin or clothes , please wash it off immediately by using soap and water.

5.2 HANDLING

- 5.2.1 Avoid any strong mechanical shock which can break the glass.
- 5.2.2 Avoid static electricity which can damage the CMOS LSI—When working with the module , be sure to ground your body and any electrical equipment you may be using.
- 5.2.3 Do not remove the panel or frame from the module.
- 5.2.4 The polarizing plate of the display is very fragile. So , please handle it very carefully , do not touch , push or rub the exposed polarizing with anything harder than an HB pencil lead (glass , tweezers , etc.)
- 5.2.5 Do not wipe the polarizing plate with a dry cloth , as it may easily scratch the surface of plate.
- 5.2.6 Do not touch the display area with bare hands , this will stain the display area.
- 5.2.7 Do not use ketonics solvent & aromatic solvent. Use with a soft cloth soaked with a cleaning naphtha solvent.

5.3 STORAGE

- 5.3.1 Store the panel or module in a dark place where the temperature is 25 ± 5 and the humidity is below 65% RH.
- 5.3.2 Do not place the module near organics solvents or corrosive gases.
- 5.3.3 Do not crush , shake , or jolt the module.



5.4 TERMS OF WARRANTY

5.4.1 Applicable warrant period

The period is within thirteen months since the date of shipping out under normal using and storage conditions.

5.4.2 Unaccepted responsibility

This product has been manufactured to your company' s specification as a part for use in your company' s general electronic products. It is guaranteed to perform according to delivery specifications. For any other use apart from general electronic equipment , we cannot take responsibility if the product is used in medical devices , nuclear power control equipment , aerospace equipment , fire and security systems or any other applications in which there is a direct risk to human life and where extremely high levels of reliability are required.



POWERTIP TECHNOLOGY CORPORATION

DISPLAY DEVICES FOR BETTER ELECTRONIC DESIGN

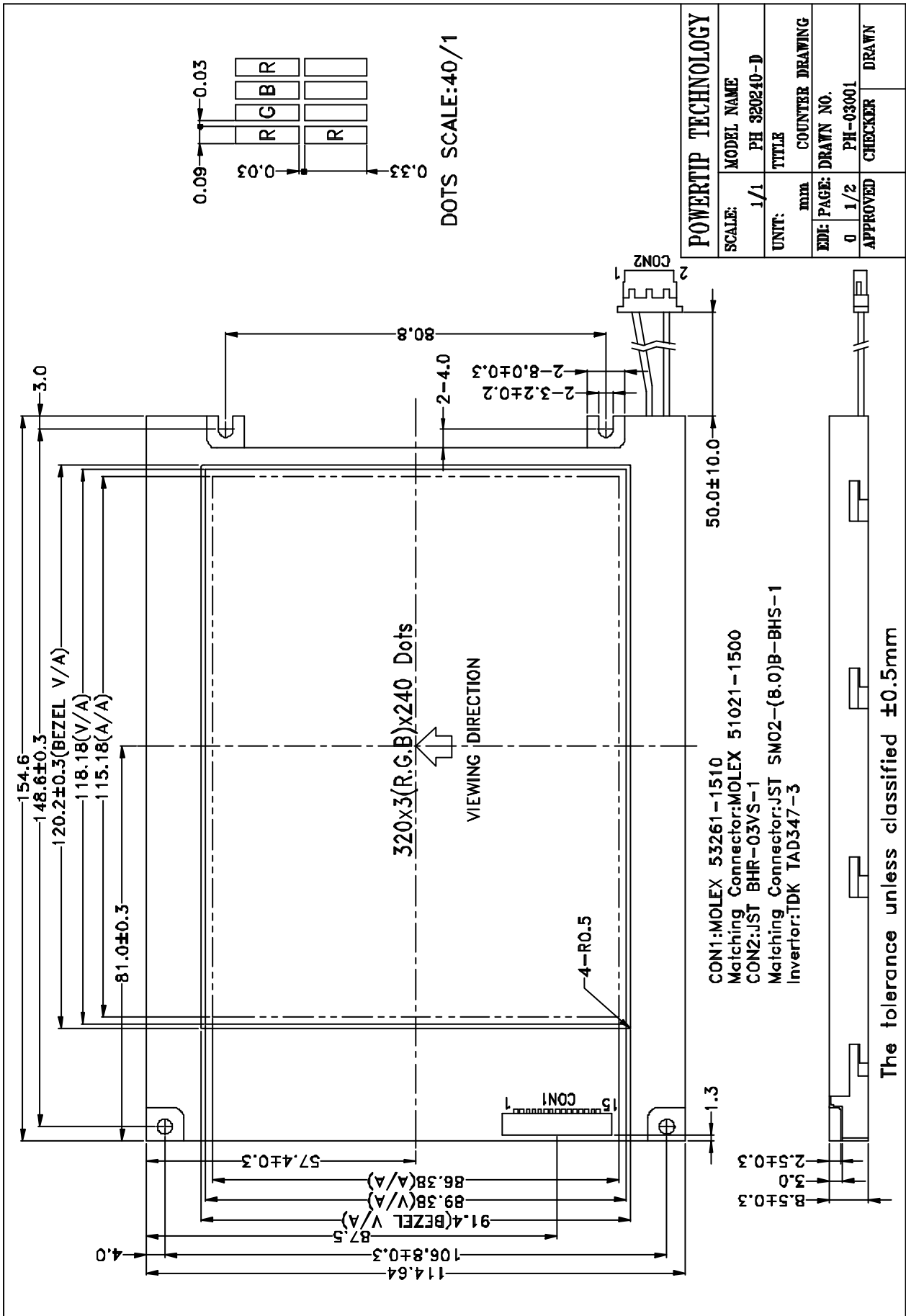

POWER TIP TECHNOLOGY CORPORATION
 DISPLAY DEVICES FOR BETTER ELECTRONIC DESIGN

CON1 Interface pin assignment

PIN NO.	SIGNAL
1	FRM
2	CL1
3	CL2
4	D.OFF
5	VDD
6	VSS
7	VLCD
8	DB7
9	DB6
10	DB5
11	DB4
12	DB3
13	DB2
14	DB1
15	DB0

CON2

CCFL B/L pin assignment

PIN NO.	SIGNAL
1	HV+
-	NC
2	HV-

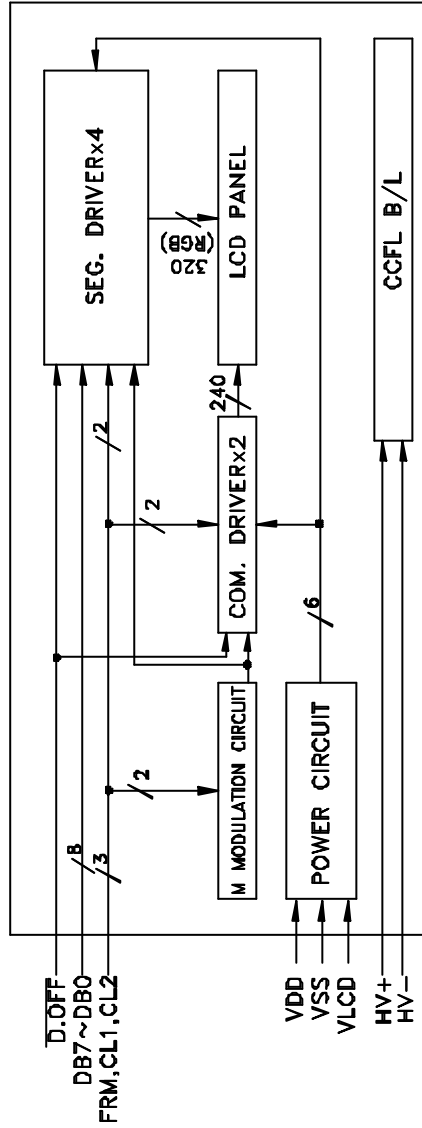

POWERTIP TECHNOLOGY	
SCALE:	MODEL NAME
N/A	PH 320240-D
UNIT:	TITLE
0	COUNTER DRAWING
2/2	EDJ: PAGE: DRAWN NO.
PH-03001	APPROVED
CHECKER	DRAWN

