

Features

- N-Channel, 5V Logic Level Control
- Enhancement mode
- Very low on-resistance @ $V_{GS}=4.5\text{ V}$
- Fast Switching
- 100% Avalanche test
- Pb-free lead plating; RoHS compliant



Part ID	Package Type	Marking	Tape and reel information
VSI090N10MS	TO-251	090N10	75pcs/Tube

V_{DS}	100	V
$R_{DS(on),typ@VGS=10V}$	78	m Ω
$R_{DS(on),typ@VGS=4.5V}$	82	m Ω
I_D	15	A

TO-251

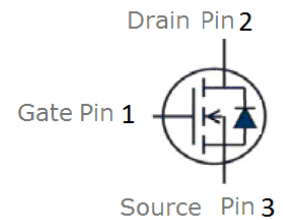

Maximum ratings, at $T_j=25\text{ }^\circ\text{C}$, unless otherwise specified

Symbol	Parameter	Rating	Unit	
$V_{(BR)DSS}$	Drain-Source breakdown voltage	100	V	
V_{GS}	Gate-Source voltage	± 20	V	
I_D	Continuous drain current@ $V_{GS}=10V$	$T_C = 25^\circ\text{C}$	15	A
		$T_C = 70^\circ\text{C}$	9.6	A
I_{DM}	Pulse drain current tested ①	$T_C = 25^\circ\text{C}$	40	A
P_D	Maximum power dissipation	$T_C = 25^\circ\text{C}$	30	W
I_S	Diode Continuous Forward Current	$T_C = 25^\circ\text{C}$	15	A
I_{AS}	Avalanche Current Max	$L=0.5\text{mH}$	11	A
E_{AS}	Avalanche energy, single pulsed ②		9	mJ
T_{STG}, T_J	Storage and operating temperature range		-55 to 175	$^\circ\text{C}$
Thermal characteristics				
$R_{\theta JA}$	Thermal Resistance Junction-Ambient	60	$^\circ\text{C/W}$	
$R_{\theta JC}$	Thermal Resistance-Junction to Case	5	$^\circ\text{C/W}$	

Typical Electrical Characteristics

Symbol	Parameter	Condition	Min.	Typ.	Max.	Unit
Static Electrical Characteristics @ T_J = 25°C (unless otherwise stated)						
V _{(BR)DSS}	Drain-Source Breakdown Voltage	V _{GS} =0V, I _D =250μA	100	--	--	V
I _{DSS}	Zero Gate Voltage Drain Current(Tc=25°C)	V _{DS} =100V, V _{GS} =0V	--	--	1	μA
	Zero Gate Voltage Drain Current(Tc=125°C)	V _{DS} =100V, V _{GS} =0V	--	--	100	μA
I _{GSS}	Gate-Body Leakage Current	V _{GS} =±20V, V _{DS} =0V	--	--	±100	nA
V _{GS(TH)}	Gate Threshold Voltage	V _{DS} =V _{GS} , I _D =250μA	1.0	2.0	3.0	V
R _{DS(ON)}	Drain-Source On-State Resistance ^③	V _{GS} =10V, I _D =10A	--	78	90	mΩ
R _{DS(ON)}	Drain-Source On-State Resistance ^③	V _{GS} =4.5V, I _D =5A	--	82	100	mΩ
Dynamic Electrical Characteristics @ T_J = 25°C (unless otherwise stated)						
C _{iss}	Input Capacitance	V _{DS} =30V, V _{GS} =0V, f=1MHz	--	525	--	pF
C _{oss}	Output Capacitance		--	41	--	pF
C _{rss}	Reverse Transfer Capacitance		--	36	--	pF
R _g	Gate Resistance		--	2.6	--	Ω
Q _g	Total Gate Charge	V _{DS} =50V, I _D =3A, V _{GS} =10V	--	15.6	--	nC
Q _{gs}	Gate-Source Charge		--	3.2	--	nC
Q _{gd}	Gate-Drain Charge		--	4.4	--	nC
Switching Characteristics						
t _{d(on)}	Turn-on Delay Time	V _{DD} =50V, I _D =1A, R _G =6.8Ω, V _{GS} =4.5V	--	8	--	nS
t _r	Turn-on Rise Time		--	4.5	--	nS
t _{d(off)}	Turn-Off Delay Time		--	26	--	nS
t _f	Turn-Off Fall Time		--	3.8	--	nS
Source- Drain Diode Characteristics @ T_J = 25°C (unless otherwise stated)						
V _{SD}	Forward on voltage	I _{SD} =10A, V _{GS} =0V	--	0.89	1.20	V
t _{rr}	Reverse Recovery Time	T _J =25°C, I _{sd} =10A, V _{GS} =0V di/dt=500A/μs	--	26	--	nS
Q _{rr}	Reverse Recovery Charge		--	115	--	nC

NOTE:

- ① Repetitive rating; pulse width limited by max. junction temperature
- ② Limited by T_{Jmax}, starting T_J = 25°C, L = 0.5mH, R_G = 25Ω, I_{AS} = 6A, V_{GS} = 10V. Part not recommended for use above this value.
- ③ Pulse width ≤ 300μs; duty cycle ≤ 2%.

Typical Characteristics

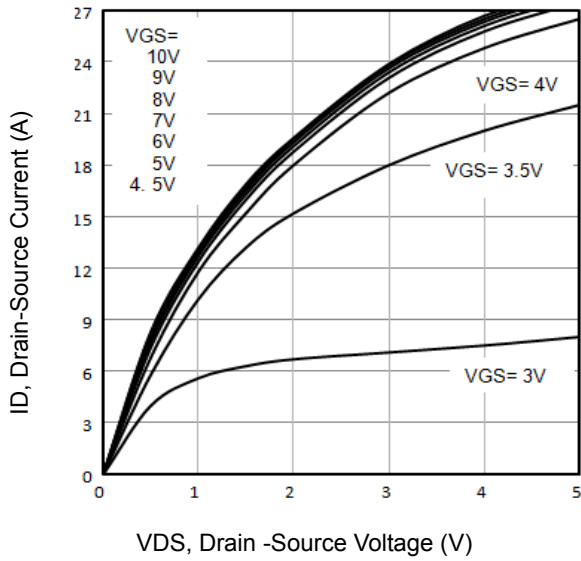

Fig1. Typical Output Characteristics

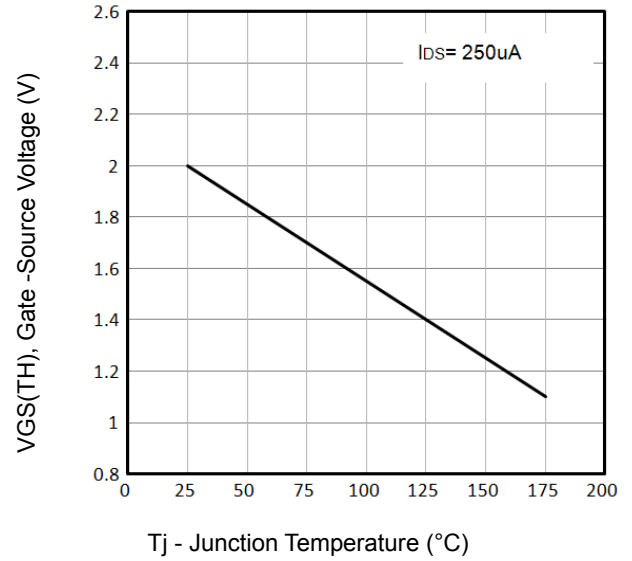

Fig2. $V_{GS(TH)}$ Gate-Source Voltage Vs. T_j

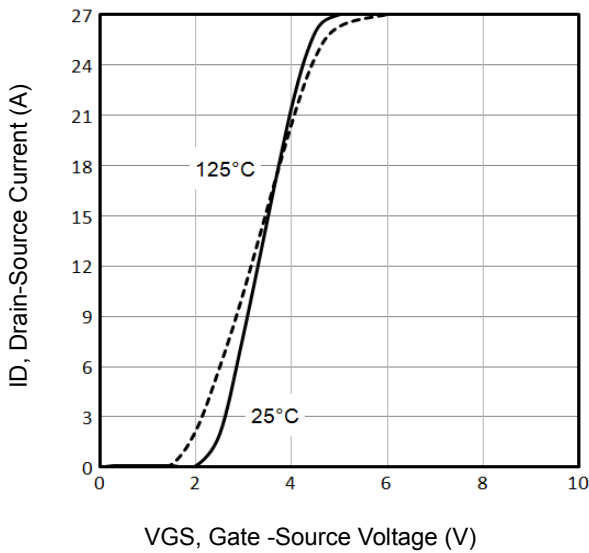

Fig3. Typical Transfer Characteristics

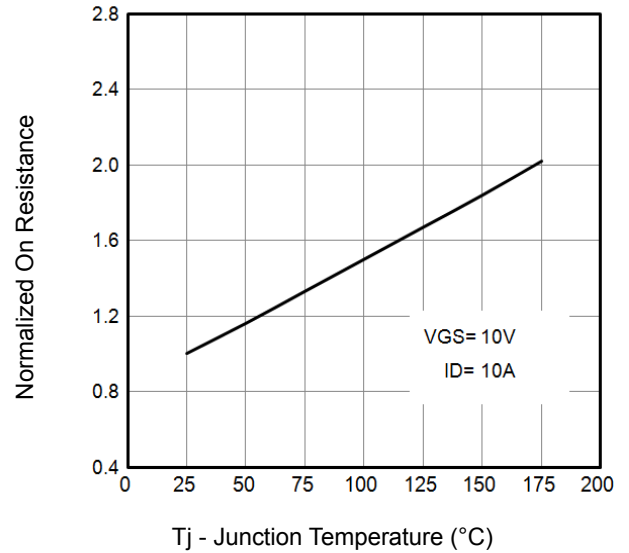

Fig4. Normalized On-Resistance Vs. T_j

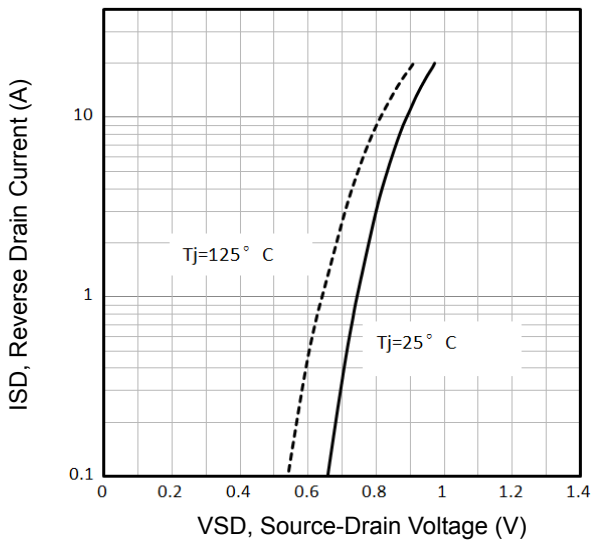

Fig5. Typical Source-Drain Diode Forward Voltage

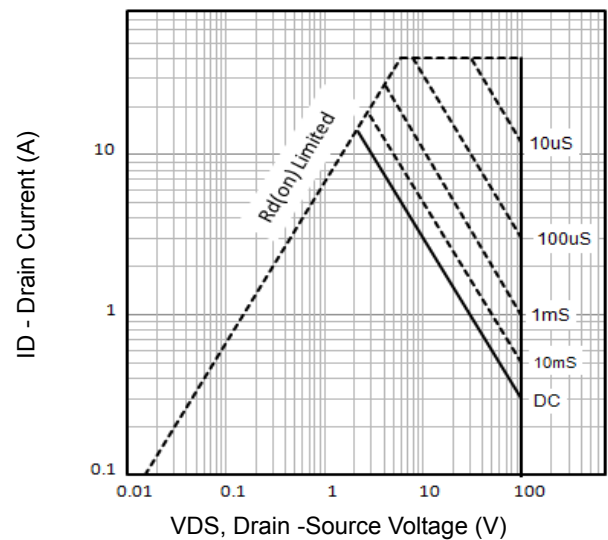

Fig6. Maximum Safe Operating Area

Typical Characteristics

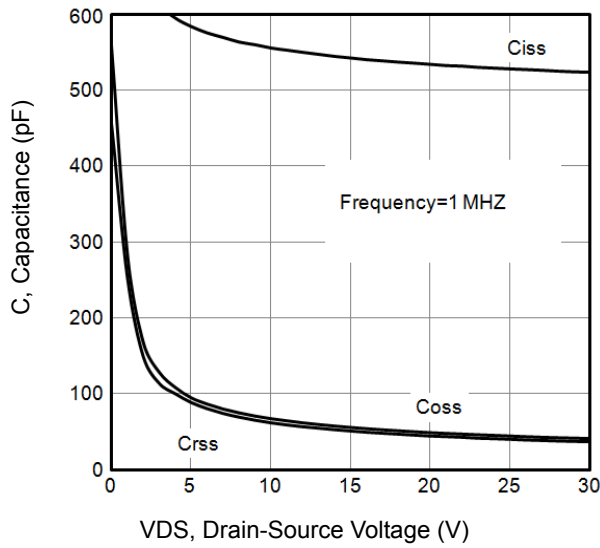

Fig7. Typical Capacitance Vs. Drain-Source Voltage

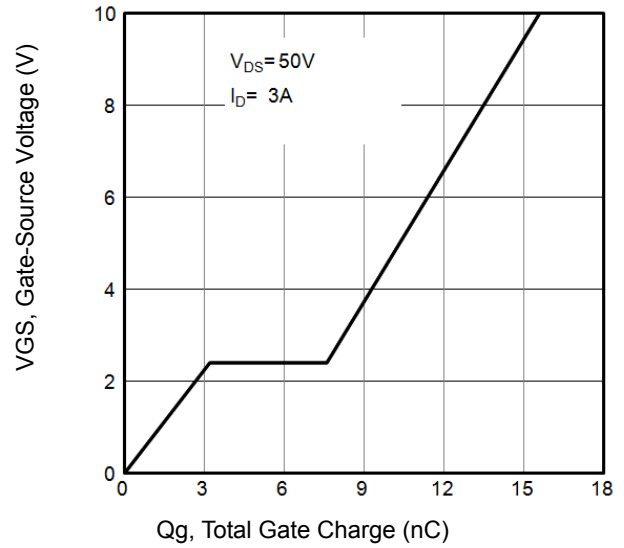

Fig8. Typical Gate Charge Vs. Gate-Source Voltage

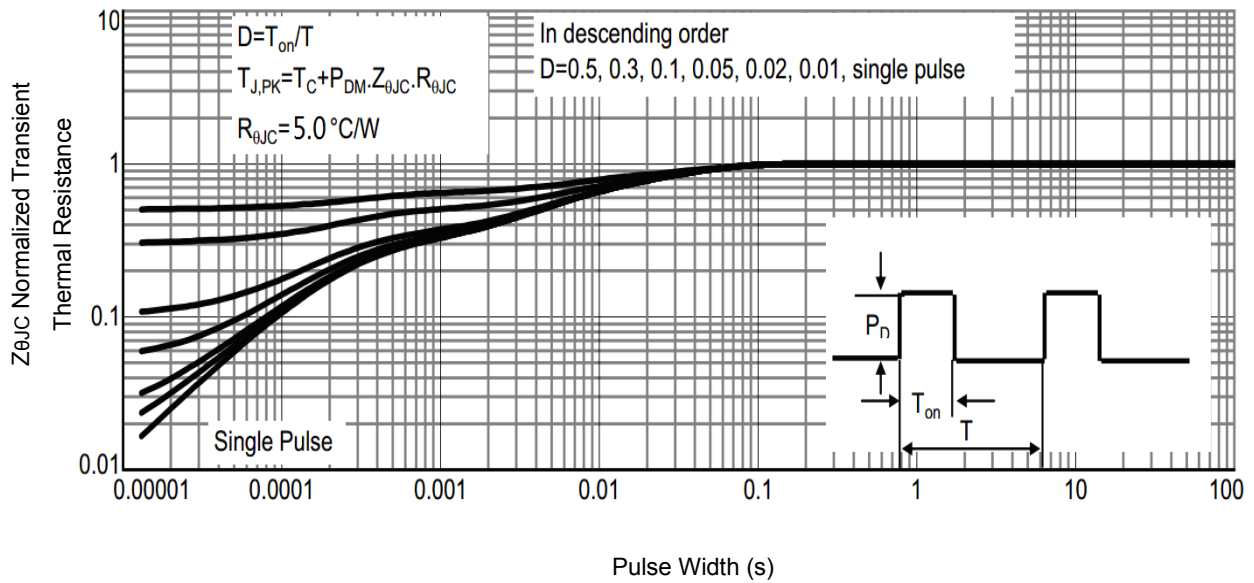

Fig9. Normalized Maximum Transient Thermal Impedance

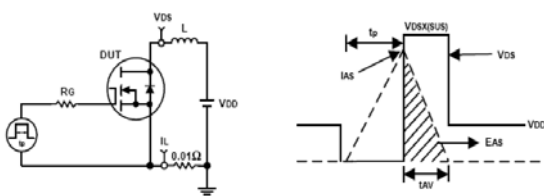

Fig10. Unclamped Inductive Test Circuit and waveforms

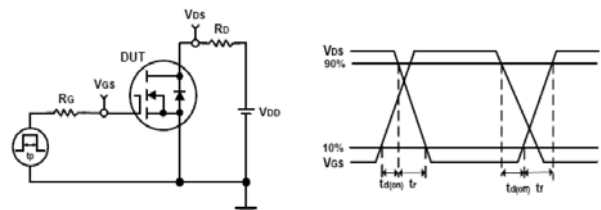
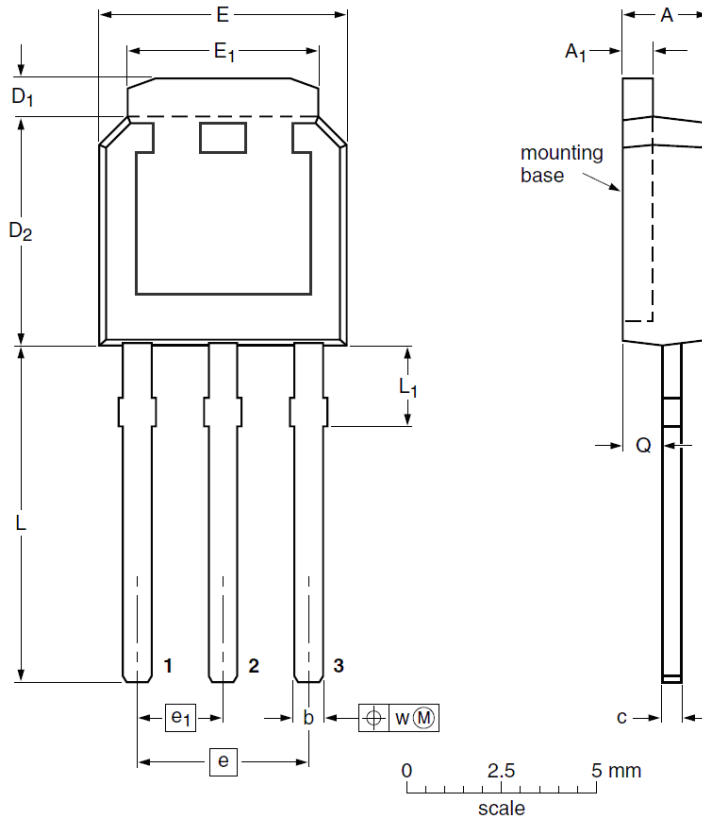

Fig11. Switching Time Test Circuit and waveforms

TO-251 Package Outline



DIMENSIONS (unit : mm)

Label	Min	Typ	Max	Label	Min	Typ	Max
A	2.22	2.30	2.38	A ₁	0.46	0.55	0.93
b	0.71	0.78	0.89	c	0.46	0.51	0.56
D ₁	0.96	1.02	1.10	D ₂	5.98	6.05	6.22
E	6.47	6.60	6.73	E ₁	5.20	5.33	5.55
e	--	4.57	--	e ₁	--	2.28	--
L	9.20	9.38	9.60	L ₁	--	2.70	--
Q	1.00	1.05	1.10	w	--	0.30	--

Customer Service

Sales and Service:

sales@vgsemi.com

Vanguard Semiconductor CO., LTD

TEL: (86-755) -26902410

FAX: (86-755) -26907027

WEB: www.vgsemi.com