



# Ultra Low Phase Noise VCXO VBLD861-Series



2111 Comprehensive Drive

Aurora, Illinois 60505

Phone: 630-851-4722

Fax: 630-851-5040

www.conwin.com

## Description:

The Connor-Winfield RoHS compliant VBLD861 is a 3.3V Voltage Controlled Crystal Oscillator (VCXO) with LVC MOS output. The VBLD861 is designed with a 3rd overtone crystal for ultra-low phase noise and jitter performance.

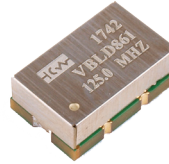

## Features:

- 3.3 Vdc Operation
- Pull Range:  $\pm 20$ ppm
- Temperature Range Options:  
0 to 85°C, 0 to 70°C,  
-40 to 85°C, and -20 to 70°C
- Low Jitter: 60fs Typical
- LVC MOS Output
- 9x14mm SMT Package
- Tape and Reel Packaging
- RoHS Compliant / Lead Free

## Package Outline

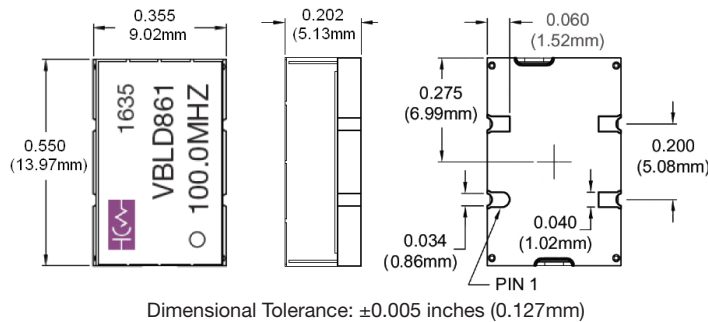

## Suggested Pad Layout

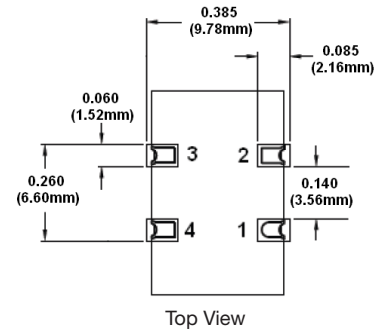

## Pad Connections

- 1: Control Voltage (Vc) \_\_\_\_\_
- 2: Ground \_\_\_\_\_
- 3: Output \_\_\_\_\_
- 4: Supply Voltage (Vdd) \_\_\_\_\_

## Ordering Information

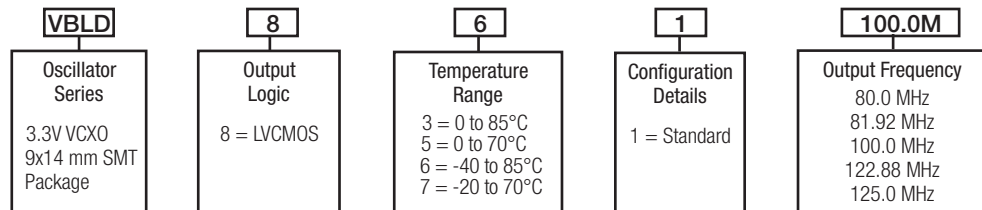

Example Part Numbers:  
VBLD861-100.0M  
VBLD861-081.92M





## Absolute Maximum Ratings

Parameter	Minimum	Nominal	Maximum	Units	Notes
Storage Temperature	-40	-	85	°C	
Supply Voltage (Vdd)	-0.5	-	4.6	Vdc	
Control Voltage (Vc)	-0.5	-	Vdd + 0.5	Vdc	

## Operating Specifications

Parameter	Minimum	Nominal	Maximum	Units	Notes
Center Frequency: (Fo)	80	-	125	MHz	
Operating Temperature Range					
Option 3	0	-	85	°C	
Option 5	0	-	70	°C	
Option 6	-40	-	85	°C	
Option 7	-20	-	70	°C	
Frequency Stability vs Temperature	-	±10	-	PPM	
Frequency Stability vs Supply Voltage	-0.2	-	0.2	PPM	3.3V+/-5%
Frequency Stability vs Aging (10 Yrs)	-	-	±5	PPM	
Supply Voltage: (Vdd)	3.135	3.3	3.465	Vdc	
Supply Current: (Idd)	-	15	30	mA	
Jitter @ Fo=100 MHz					
Period Jitter	-	3.0	5.0	ps RMS	
Integrated Phase Jitter	-	60	100	fs RMS	1
Typical SSB Phase Noise @ Fo=100 MHz					
@ 10 Hz offset	-	-80	-	dBc/Hz	
@ 100 Hz offset	-	-110	-	dBc/Hz	
@ 1 kHz offset	-	-140	-	dBc/Hz	
@ 10 kHz offset	-	-155	-	dBc/Hz	
@ 100 kHz offset	-	-162	-	dBc/Hz	
@ 1 MHz offset	-	-165	-	dBc/Hz	
Start-Up Time	-	-	10	ms	

## Input Characteristics

Parameter	Minimum	Nominal	Maximum	Units	Notes
Control Voltage Range (Vc)	0.3	1.65	3.0	Vdc	
Pull Slope at Vc=1.65V	-	15	-	ppm/V	
Pull Range at 25°C	-	±20	-	ppm	
Absolute Pull Range (APR)	±5	-	-	ppm	2
Monotonic Linearity	-10	-	10	%	
DC Input Impedance	50K	-	-	Ohm	3
Modulation Bandwidth (3dB)	10	-	-	kHz	

## LVC MOS Output Characteristics

Parameter	Minimum	Nominal	Maximum	Units	Notes
Load	-	15	-	pF	
Voltage (High) Voh	0.9Vdd	-	-	Vdd	
(Low) Vol	-	-	0.1Vdd	Vdd	
Duty Cycle at 50% Level	45	50	55	%	
Rise / Fall Time: 20% to 80%	-	-	2	ns	

### Notes:

- BW= 12 kHz to 20 MHz
- Absolute Pull Range (APR) is the minimum guaranteed pull range of the VCXO under all conditions over lifetime operation including calibration @ 25°C, frequency stability vs. the change in temperature, frequency vs. change in supply voltage, frequency vs. change in load, shock and vibration and 10 years aging. The APR is referenced to (Fo). Positive transfer function.
- Measured from pin 1 to ground.

Bulletin	VX671
Page	2 of 4
Revision	04
Date	07 June 2018

## Package Characteristics:

<b>Package</b>	Non-hermetic package consisting of FR4 substrate and grounded metal cover.
----------------	--

## Environmental Characteristics

<b>Shock</b>	500 G's 1ms, Halfsine, 3 shocks per direction, per MIL-STD 202G, Method 213B Test Condition D.
<b>Sinusoidal Vibration</b>	0.06" D.A. or 10G's Peak, 10 to 500 Hz, per MIL-STD-202G, Method 204D, Test Condition A.
<b>Random Vibration</b>	5.35 G's rms. 20 to 2000 Hz per MIL-STD-202G, Method 214, Test Condition 1A, 15 minutes each axis.
<b>Moisture</b>	10 cycles, 95% RH, Per MIL-STD-202G, Method 112.
<b>Marking Permanency</b>	Per MIL-STD-202G, Method 215J.

<b>Solder Process Recommendations:</b>	RoHS compliant, lead free. See solder profile on page 4.
<b>In-line reflow:</b>	Refer to recommended reflow pre-heat and reflow temperatures on page 4. Component solder is Pb free high temperature eutectic alloy with a melting point of 221°C.
<b>In-line oven profile:</b>	We recommend using KIC profiler or similar device placing one of the thermocouples on the device to insure that the internal package temperature does not exceed 221°C.
<b>Removal of device:</b>	If for any reason the device needs to be removed from the board, use a temperature controlled repair station with profile monitoring capabilities. Following a monitored profile will insure the device is properly pre-heated prior to reflow. Refer to IPC 610E for inspection guidelines.

<b>Recommended Cleaning Process:</b> (If required)	Device is non-hermetic. <b>Do not submerge the device.</b> We recommend in-line warm water wash with air knife and drying capabilities. If cleaner does not have drying capability, then use hot air circulated oven. Boards should be placed in the oven vertically for good water runoff. <b>Device must be dried properly prior to use!</b> <b>Note:</b> If saponifier is used make sure the device is rinsed properly to insure all residues are removed. PH of saponifier should not exceed 10.
<b>Drying Temperature:</b>	Between 85 to 100°C.
<b>Drying Time:</b>	Time will vary depending on the board size.

## Typical Frequency vs Temperature Fo=100MHz

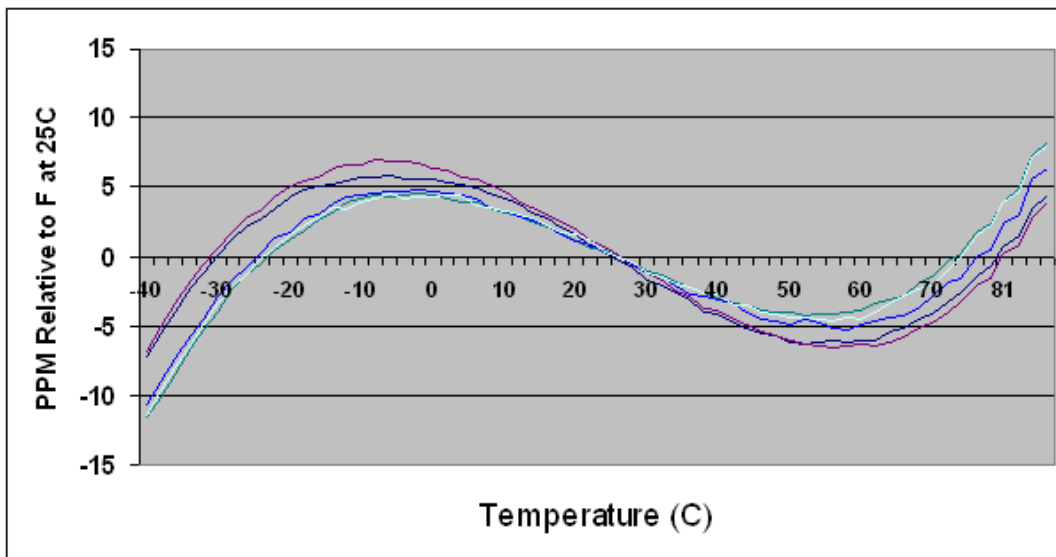

## Typical Phase Noise Fo = 100MHz

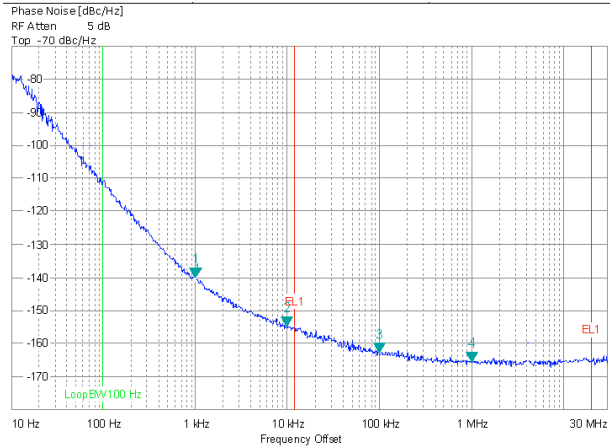

## Output Waveform

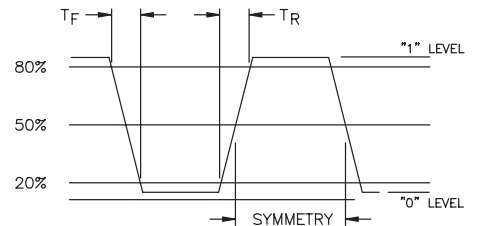

## Test Circuit

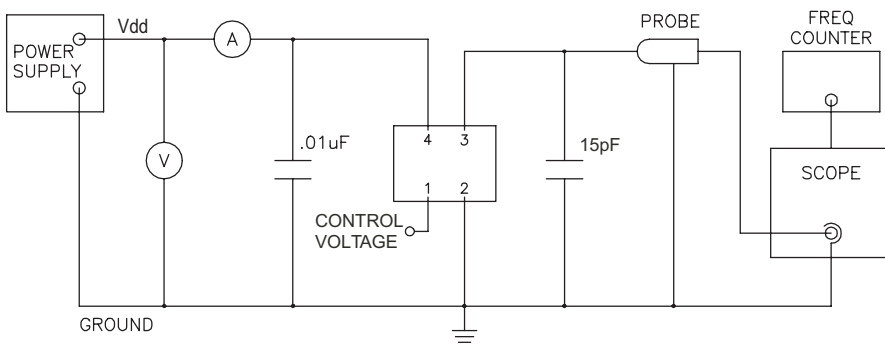

## Solder Profile

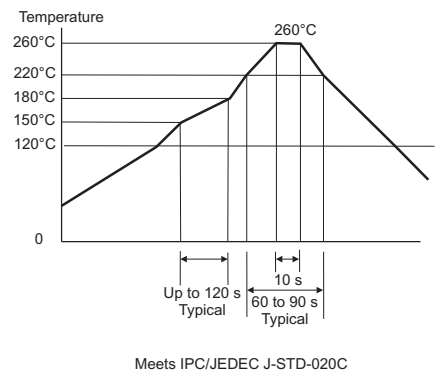

## Tape and Reel Information

MEETS EIA-481A & EIAJ-1009B  
 500 PCS/REEL MAXIMUM

→ DIRECTION OF FEED (CUSTOMER)

