

TFT LCD Approval Specification

MODEL NO.: V201V2 - T02

Customer: _____ Approved by: _____ Note:
--

www.jxlcd.com

LCD TV Head Division	
AVP	郭振隆

QRA Dept.	TVHD / PDD		
	DDIII	DDII	DDI
Approval	Approval	Approval	Approval
陳永一	李汪洋	藍文錦	林文聰

LCD TV Marketing and Product Management Division	
Product Manager	徐子祥 陳立宜

- CONTENTS -

REVISION HISTORY	-----	3
1. GENERAL DESCRIPTION	-----	4
1.1 OVERVIEW		
1.2 FEATURES		
1.3 APPLICATION		
1.4 GENERAL SPECIFICATIONS		
1.5 MECHANICAL SPECIFICATIONS		
2. ABSOLUTE MAXIMUM RATINGS	-----	5
2.1 ABSOLUTE RATINGS OF ENVIRONMENT		
2.2 ELECTRICAL ABSOLUTE RATINGS		
2.2.1 TFT LCD MODULE		
2.2.2 BACKLIGHT UNIT		
3. ELECTRICAL CHARACTERISTICS	-----	7
3.1 TFT LCD MODULE		
3.2 BACKLIGHT UNIT		
3.2.1 CCFL CHARACTERISTICS		
4. BLOCK DIAGRAM	-----	10
4.1 TFT LCD MODULE		
4.2 BACKLIGHT UNIT		
5. INTERFACE PIN CONNECTION	-----	11
5.1 TFT LCD MODULE		
5.2 COLOR DATA INPUT ASSIGNMENT		
6. INTERFACE TIMING	-----	13
6.1 INPUT SIGNAL TIMING SPECIFICATIONS		
6.2 POWER ON/OFF SEQUENCE		
7. OPTICAL CHARACTERISTICS	-----	15
7.1 TEST CONDITIONS		
7.2 OPTICAL SPECIFICATIONS		
8. PACKAGING	-----	19
8.1 PACKING SPECIFICATIONS		
8.1 PACKING METHOD		
9. DEFINITION OF LABELS	-----	21
9.1 CMO MODULE LABEL		
10. PRECAUTIONS	-----	22
10.1 ASSEMBLY AND HANDLING PRECAUTIONS		
10.2 SAFETY PRECAUTIONS		
10.3 SAFETY REGULATION		
11. MECHANICAL CHARACTERISTICS	-----	23

REVISION HISTORY

Version	Date	Page (New)	Section	Description
Ver 2.0	Feb. 4,'04	All	All	Approval Specification was first issued.
Ver 2.1	Mar. 25,'04	6 8 10 13 15 22	2.2 3.2.1 4.2 6.1 7.1 10.3	Add 2.2.2 Backlight unit chart Remove power consumption parameter Remove Min. Lamp Turn On Voltage Change Max. Lamp Turn On Voltage: 3000 V _{RMS} → 1600 V _{RMS} (Ta = 0 °C) 3000 V _{RMS} → 1320 V _{RMS} (Ta = 25 °C) Add Note (3) and Note (8) Backlight unit block diagram shows all lamps Add Input data term, Setup time and Hold time Change Test Condition: inverter frequency 33KHz → 61KHz Add SAFETY REGULATION
Ver 2.2	Apr. 30,'04	8 9 13	3.2.1 3.2.1 6.1	Min. Lamp Life Time: 50K → 50,000 Typ. Lamp Life Time: 60K → 60,000 Return cable Pin#1 wire color : Gray → Pink Note (8) is revised as: Backlight unit turn on voltage is 1500V _{RMS} (Max) when Ta = 0 °C, 1150V _{RMS} (Max) when Ta = 25 °C. Input Signal Spec : Frame Rate Min. : 47 (Hz) Input Data Term –Typ. Setup Time: 10 → - Input Data Term –Typ. Hold Time: 10 → - Add De Term Input Signal Timing Diagram is revised.
		17	7.2	Note(4) add : "Gray to gray value is optimized in NTSC video system. In other video system, video quality will depend on signal quality level."
Ver 2.3	Nov. 22,'04	10 11 23 24	4.1 5.1 11 11	Input connector : Hirose FH12-50S-0.5SH → P-TWO AF7501-N2G1Z Connector Part No. : FH12-50S-0.5SH(Hirose) → AF7501-N2G1Z (P-TWO) The Drawing was modified. The Drawing was modified.

1. GENERAL DESCRIPTION

1.1 OVERVIEW

V201V2-T02 is a 20.1" TFT Liquid Crystal Display module with 12-CCFL Backlight unit and 1ch-TTL interface. This module supports 640 x 480 VGA format and can display true 16.7M colors (8-bit/color).

1.2 FEATURES

- High brightness (500 nits)
- High contrast ratio (600:1)
- Fast response time
- High color saturation NTSC 75%
- VGA (640 x 480 pixels) resolution
- DE (Data Enable) only mode
- TTL interface

1.3 APPLICATION

- TFT LCD TV

1.4 GENERAL SPECIFICATIONS

Item	Specification	Unit	Note
Active Area	408 (H) x 306 (V) (20.1" diagonal)	mm	(1)
Bezel Opening Area	412 (H) x 310 (V)	mm	
Driver Element	a-si TFT active matrix	-	-
Pixel Number	640 x R.G.B. x 480	pixel	-
Pixel Pitch(Sub Pixel)	0.2125 (H) x 0.6375 (V)	mm	-
Pixel Arrangement	RGB vertical stripe	-	-
Display Colors	16.7M	color	-
Display Operation Mode	Transmissive mode / Normally black	-	-
Surface Treatment	Hardness : 3H, Haze : 40% Anti-reflective coating < 2% reflection	-	-

1.5 MECHANICAL SPECIFICATIONS

Item		Min.	Typ.	Max.	Unit	Note
Module Size	Horizontal(H)	435.7	436.0	436.4	mm	(1)
	Vertical(V)	329.0	329.3	329.7	mm	
	Depth(D)	-	36.78	37.78	mm	with PCB Cover
Weight		-	2000	2100	g	

Note (1) Please refer to the attached drawings for more information of front and back outline dimensions.

2. ABSOLUTE MAXIMUM RATINGS

2.1 ABSOLUTE RATINGS OF ENVIRONMENT

Item	Symbol	Value		Unit	Note
		Min.	Max.		
Storage Temperature	T _{ST}	-20	+60	°C	(1)
Operating Ambient Temperature	T _{OP}	0	50	°C	(1), (2)
Shock (Non-Operating)	S _{NOP}	-	50	G	(3), (5)
Vibration (Non-Operating)	V _{NOP}	-	1.0	G	(4), (5)

Note (1) Temperature and relative humidity range is shown in the figure below.

- (a) 90 %RH Max. (Ta ≤ 40 °C).
- (b) Wet-bulb temperature should be 39 °C Max. (Ta > 40 °C).
- (c) No condensation.

Note (2) The maximum operating temperature is based on the test condition that the surface temperature of display area is less than or equal to 60 °C with LCD module alone in a temperature controlled chamber. Thermal management should be considered in your product design to prevent the surface temperature of display area from being over 60 °C. The range of operating temperature may degrade in case of improper thermal management in your product design.

Note (3) 11 ms, half sine wave, 1 time for ± X, ± Y, ± Z.

Note (4) 10 ~ 500 Hz, 10 min, 1 time each X, Y, Z.

Note (5) At testing Vibration and Shock, the fixture in holding the module has to be hard and rigid enough so that the module would not be twisted or bent by the fixture.

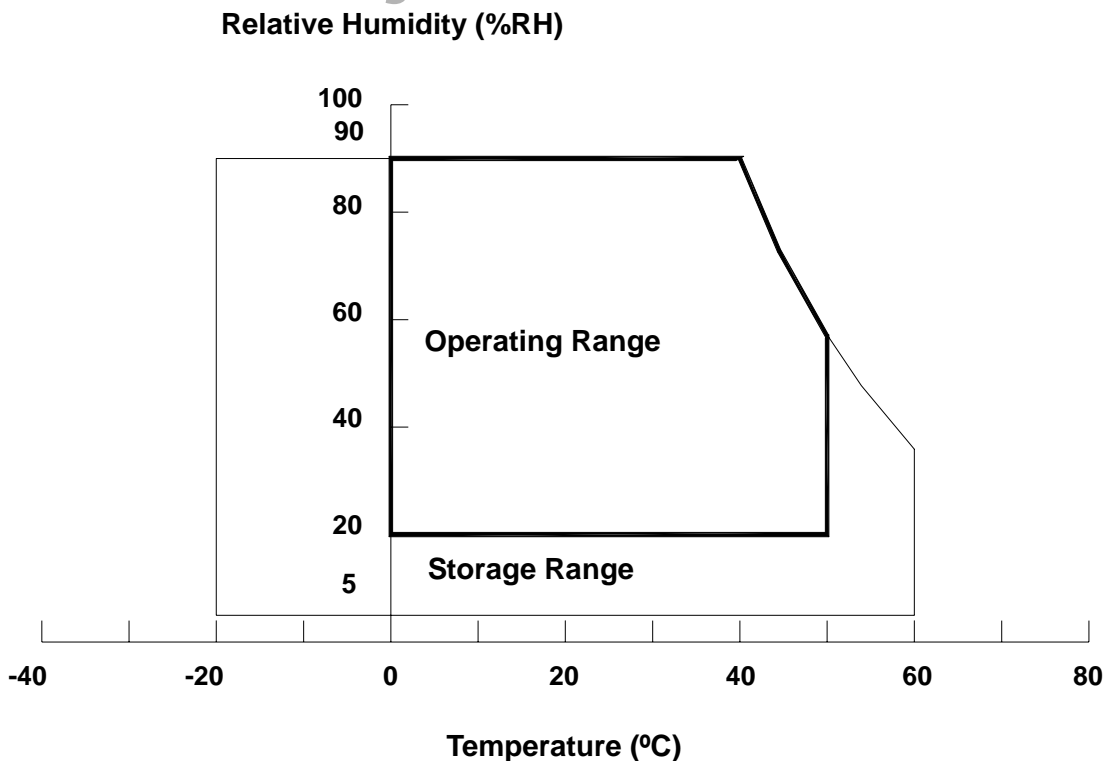

2.2 ELECTRICAL ABSOLUTE RATINGS

2.2.1 TFT LCD MODULE

Item	Symbol	Value		Unit	Note
		Min.	Max.		
Power Supply Voltage	Vcc	-0.3	+5.5	V	

2.2.2 BACKLIGHT UNIT

Item	Symbol	Min.	Type	Max.	Unit	Note
Lamp Voltage	V _L	-	-	3000	V _{RMS}	
Lamp Current	I _L	-	-	4.5	mA _{RMS}	
Lamp Frequency	F _L	-	-	70	KHz	

www.jxlcd.com

3. ELECTRICAL CHARACTERISTICS

3.1 TFT LCD MODULE

Ta = 25 ± 2 °C

Parameter	Symbol	Value			Unit	Note
		Min.	Typ.	Max.		
Power Supply Voltage	V _{CC}	4.5	5.0	5.5	V	(1)
Ripple Voltage	V _{RP}	-	150	-	mV	(2)
Rush Current	I _{RUSH}	-	1.9	2.5	A	
Power Supply Current	White	-	0.5	0.6	A	(3)
	Black	-	0.4	-	A	
	Vertical Stripe	-	0.4	0.5	A	
TTL input high threshold voltage	V _{IH}	2.7	-	3.6	V	
TTL input low threshold voltage	V _{IL}	-0.3	-	0.7	V	

Note (1) The module should be always operated within above ranges.

Note (2) Measurement Conditions:

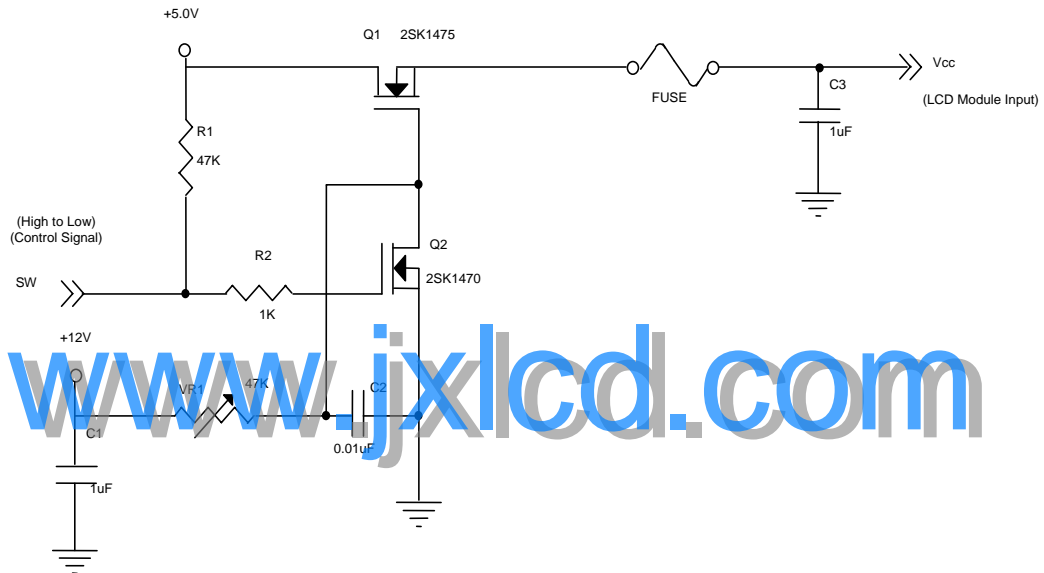

Vcc rising time is 470μs

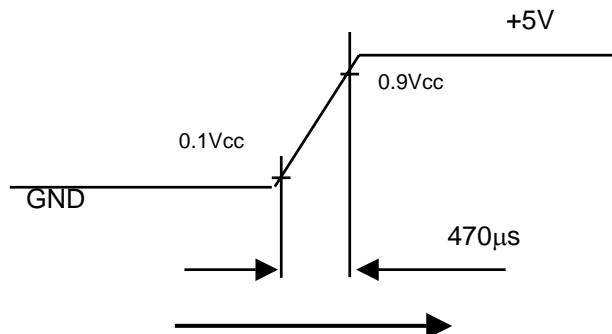

Note (3) The specified power supply current is under the conditions at $V_{CC} = 5\text{ V}$, $T_a = 25 \pm 2\text{ }^\circ\text{C}$, $f_v = 60\text{ Hz}$, whereas a power dissipation check pattern below is displayed.

a. White Pattern



Active Area

b. Black Pattern



Active Area

c. Vertical Stripe Pattern

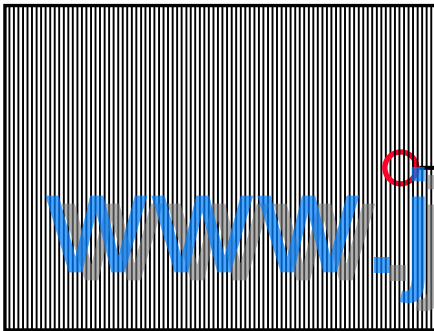

Active Area

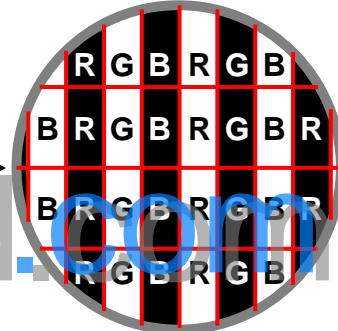

www.jxlcd.com

3.2 BACKLIGHT UNIT

3.2.1 CCFL CHARACTERISTICS

 $T_a = 25 \pm 2\text{ }^\circ\text{C}$

Parameter	Symbol	Value			Unit	Note
		Min.	Typ.	Max.		
Lamp Input Voltage	V_L	733	815	896	V_{RMS}	$I_L = 4.2\text{mA}$
Lamp Current	I_L	3.9	4.2	4.5	mA_{RMS}	
Lamp Turn On Voltage	V_S	-	-	1600	V_{RMS}	$T_a = 0\text{ }^\circ\text{C}$ (8)
		-	-	1320	V_{RMS}	$T_a = 25\text{ }^\circ\text{C}$ (8)
Operating Frequency	F_L	60	61	62	KHz	(3)
Lamp Life Time	L_{BL}	50,000	60,000	-	Hrs	

Note (1) Lamp current is measured by utilizing high frequency current meters as shown below:

Note (2) The voltage shown above should be applied to the lamp for more than 1 second after startup.

Otherwise the lamp may not be turned on.

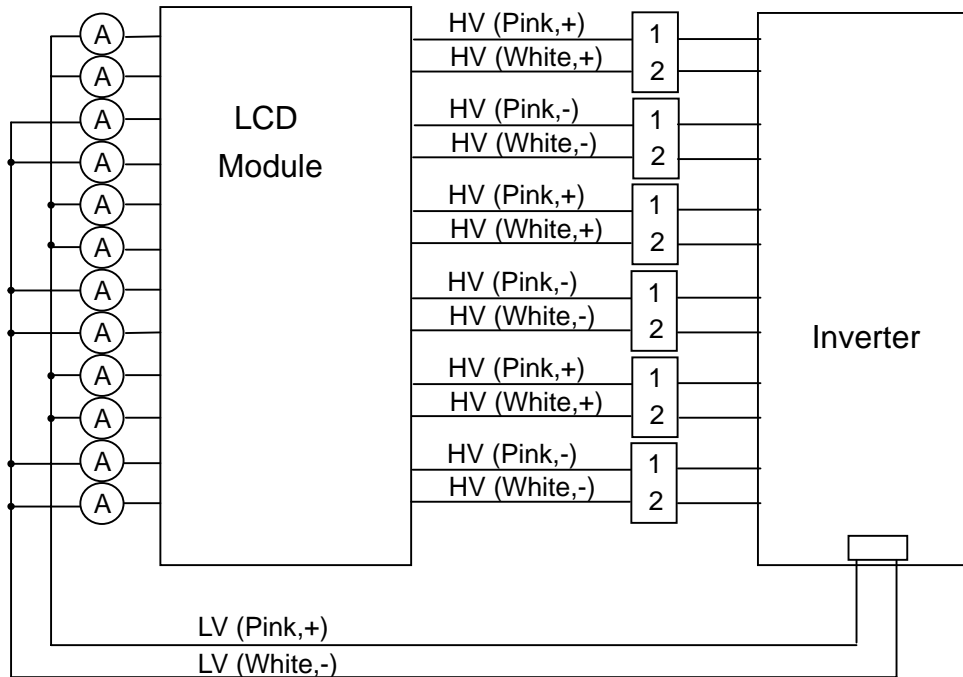

Note (3) The better oscillating frequency range for lamp application is from 40kHz to 70kHz. The oscillating frequency can be choose excluding the range $61 \pm 1\text{KHz}$. But the noise interference phenomena cannot be eliminated completely.

Note (4) The lamp frequency may produce interference with horizontal synchronous frequency from the display, and this may cause line flow on the display. In order to avoid interference, the lamp frequency should be detached from the horizontal synchronous frequency and its harmonics as far as possible.

Note (5) $P_L = (I_{\text{lamp1}} - I_{\text{lamp6}} I_L \times V_L) / 0.8$, P_L is based on the inverter efficiency, which is 80%.

Note (6) The lifetime of a lamp is defined as the time in which it continues to operate under the condition $T_a = 25 \pm 2^\circ\text{C}$ and $I_L = 4.2 \text{ mArms}$ until one of the following events occurs:

- (a) When the brightness becomes equal or less than 50% of its original value.
- (b) When the effective discharge length becomes equal or less than 80% of its original value.
 (Effective discharge length is defined as an area that has equal or more than 70% brightness compared to the brightness at the center point.)

Note (7) The waveform of the voltage output of inverter must be area-symmetric and the design of the inverter must have specifications for the modularized lamp. The performance of the Backlight, such as lifetime or brightness, is greatly influenced by the characteristics of the DC-AC inverter for the lamp. All the parameters of an inverter should be carefully designed to avoid producing too much current leakage from high voltage output of the inverter. When designing or ordering the inverter please make sure that a poor lighting caused by the mismatch of the Backlight and the inverter (miss-lighting, flicker, etc.) never occurs. If the above situation is confirmed, the module should be operated in the same manners when it is installed in your instrument.

Note (8) Backlight unit turn on voltage is $1500V_{\text{RMS}}$ (Max) when $T_a = 0^\circ\text{C}$, $1150V_{\text{RMS}}$ (Max) when $T_a = 25^\circ\text{C}$.

4. BLOCK DIAGRAM

4.1 TFT LCD MODULE

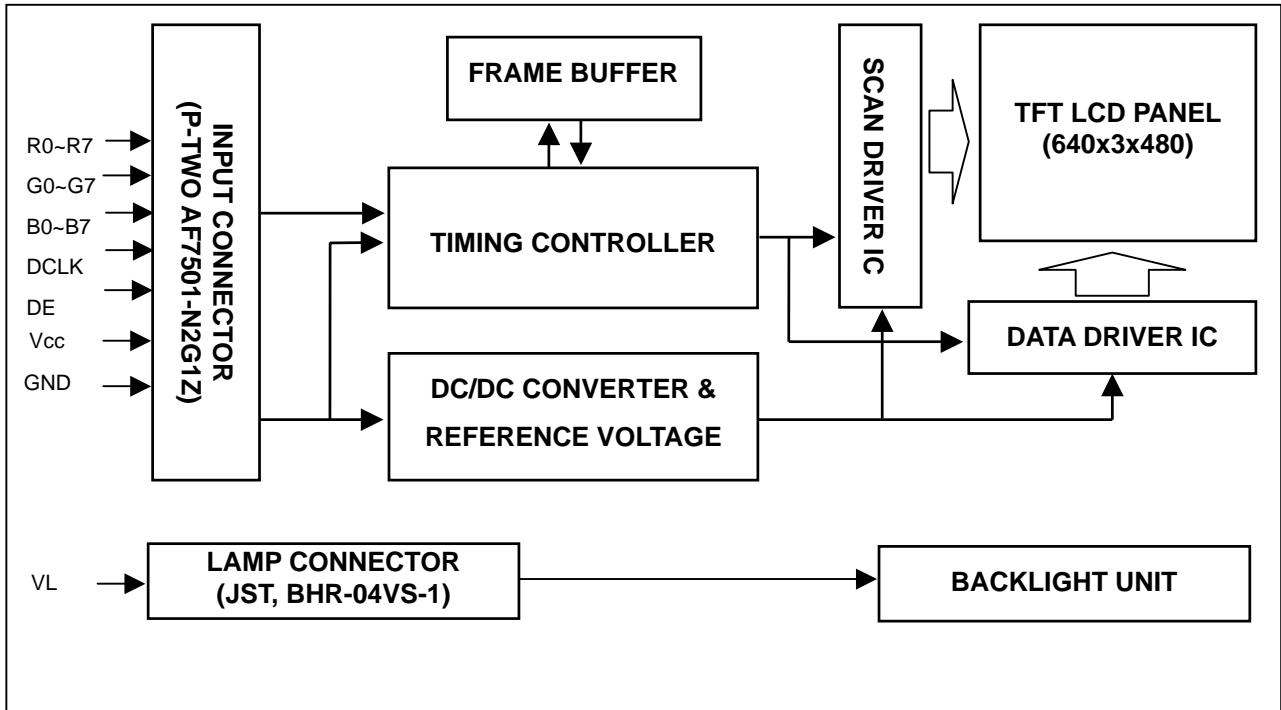

4.2 BACKLIGHT UNIT

www.jxlcd.com

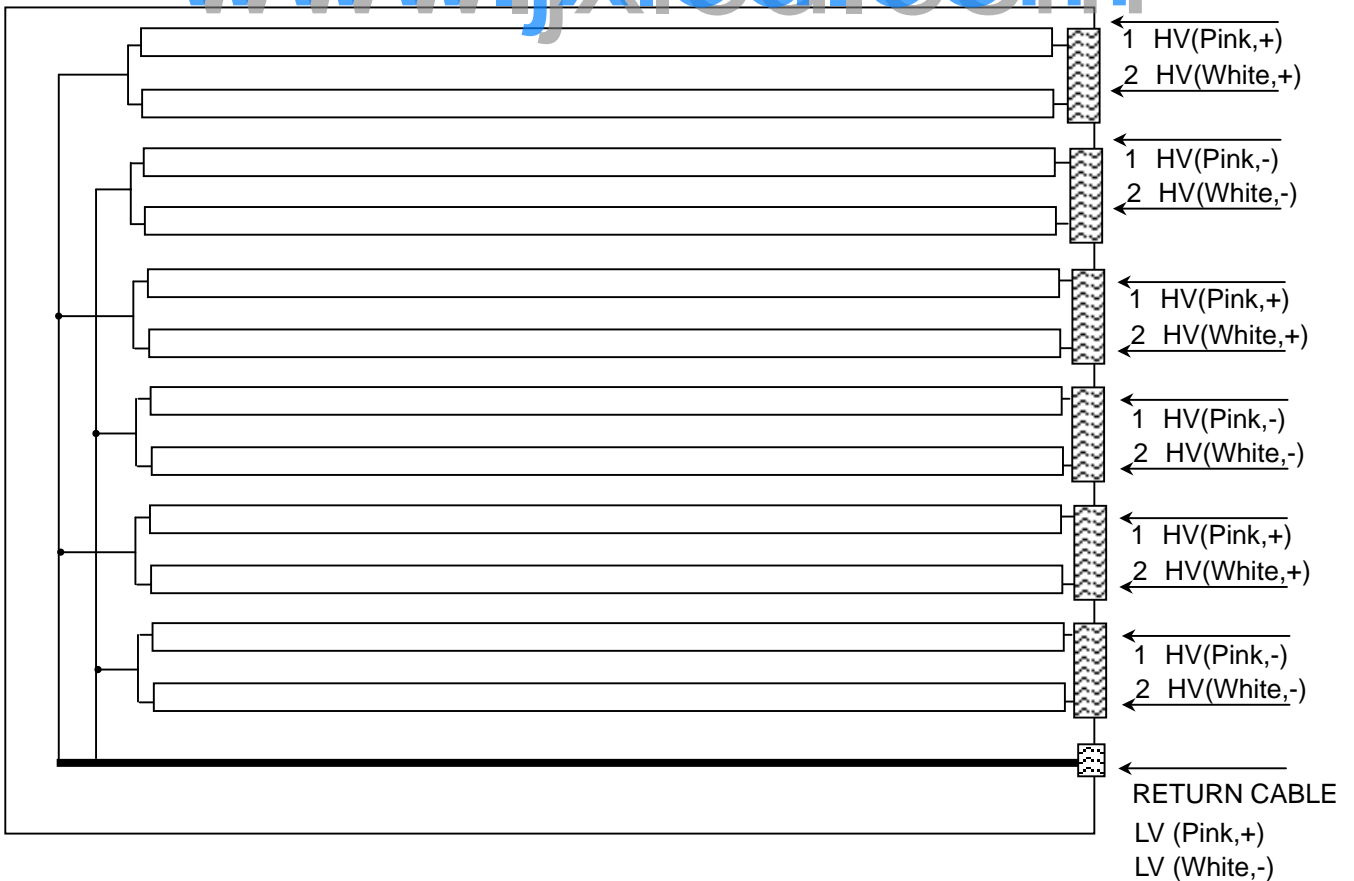

5. INTERFACE PIN CONNECTION

5.1 TFT LCD MODULE

Pin assignment

Pin	Name	Description	Pin	Name	Description
1	NC	No Connection	26	R0	Red Data
2	NC	No Connection	27	GND	Ground
3	NC	No Connection	28	G7	Green Data (G7:MSB)
4	GND	Ground	29	G6	
5	GND	Ground	30	G5	
6	VCC	Power Input (+5.0V)	31	G4	
7	VCC		32	GND	Ground
8	VCC		33	G3	Green Data
9	VCC		34	G2	
10	GND	Ground	35	G1	
11	NC		36	G0	
12	NC		37	GND	Ground
13	GND	Ground	38	B7	Blue Data (B7:MSB)
14	DE	Data Enable	39	B6	
15	GND	Ground	40	B5	
16	DCLK	Dot Clock	41	B4	
17	GND	Ground	42	GND	Ground
18	R7	Red Data (R7:MSB)	43	B3	Blue Data
19	R6		44	B2	
20	R5		45	B1	
21	R4		46	B0	
22	GND	Ground	47	GND	Ground
23	R3	Red Data	48	GND	Ground
24	R2		49	NC	No Connection
25	R1		50	NC	No Connection

Note (1) Connector Part No.: AF7501-N2G1Z (P-TWO)

Note (2) NC pin has to keep high impedance

5.2 COLOR DATA INPUT ASSIGNMENT

The brightness of each primary color (red, green and blue) is based on the 8-bit gray scale data input for the color. The higher the binary input, the brighter the color. The table below provides the assignment of color versus data input.

Color		Data Signal																						
		Red								Green								Blue						
		R7	R6	R5	R4	R3	R2	R1	R0	G7	G6	G5	G4	G3	G2	G1	G0	B7	B6	B5	B4	B3	B2	B1
Basic Colors	Black	0	0	0	0	0	0	0	0	0	0	0	0	0	0	0	0	0	0	0	0	0	0	0
	Red	1	1	1	1	1	1	1	1	0	0	0	0	0	0	0	0	0	0	0	0	0	0	0
	Green	0	0	0	0	0	0	0	0	1	1	1	1	1	1	1	1	0	0	0	0	0	0	0
	Blue	0	0	0	0	0	0	0	0	0	0	0	0	0	0	0	0	1	1	1	1	1	1	1
	Cyan	0	0	0	0	0	0	0	0	1	1	1	1	1	1	1	1	1	1	1	1	1	1	1
	Magenta	1	1	1	1	1	1	1	1	0	0	0	0	0	0	0	0	1	1	1	1	1	1	1
	Yellow	1	1	1	1	1	1	1	1	1	1	1	1	1	1	1	1	0	0	0	0	0	0	0
	White	1	1	1	1	1	1	1	1	1	1	1	1	1	1	1	1	1	1	1	1	1	1	1
Gray Scale Of Red	Red(0) / Dark	0	0	0	0	0	0	0	0	0	0	0	0	0	0	0	0	0	0	0	0	0	0	
	Red(1)	0	0	0	0	0	0	0	1	0	0	0	0	0	0	0	0	0	0	0	0	0	0	
	Red(2)	0	0	0	0	0	0	1	0	0	0	0	0	0	0	0	0	0	0	0	0	0	0	
	⋮	⋮	⋮	⋮	⋮	⋮	⋮	⋮	⋮	⋮	⋮	⋮	⋮	⋮	⋮	⋮	⋮	⋮	⋮	⋮	⋮	⋮	⋮	
	Red(253)	1	1	1	1	1	1	0	1	0	0	0	0	0	0	0	0	0	0	0	0	0	0	
	Red(254)	1	1	1	1	1	1	1	0	0	0	0	0	0	0	0	0	0	0	0	0	0	0	
	Red(255)	1	1	1	1	1	1	1	1	0	0	0	0	0	0	0	0	0	0	0	0	0	0	
	Gray Scale Of Green	Green(0) / Dark	0	0	0	0	0	0	0	0	0	0	0	0	0	0	0	0	0	0	0	0	0	0
Green(1)		0	0	0	0	0	0	0	0	0	0	0	0	0	0	1	0	0	0	0	0	0	0	
Green(2)		0	0	0	0	0	0	0	0	0	0	0	0	0	1	0	0	0	0	0	0	0	0	
⋮		⋮	⋮	⋮	⋮	⋮	⋮	⋮	⋮	⋮	⋮	⋮	⋮	⋮	⋮	⋮	⋮	⋮	⋮	⋮	⋮	⋮		
Green(253)		0	0	0	0	0	0	0	1	1	1	1	1	1	0	1	0	0	0	0	0	0	0	
Green(254)		0	0	0	0	0	0	0	1	1	1	1	1	1	1	0	0	0	0	0	0	0	0	
Green(255)		0	0	0	0	0	0	0	1	1	1	1	1	1	1	1	0	0	0	0	0	0	0	
Gray Scale Of Blue		Blue(0) / Dark	0	0	0	0	0	0	0	0	0	0	0	0	0	0	0	0	0	0	0	0	0	0
	Blue(1)	0	0	0	0	0	0	0	0	0	0	0	0	0	0	0	0	0	0	0	0	0	1	
	Blue(2)	0	0	0	0	0	0	0	0	0	0	0	0	0	0	0	0	0	0	0	0	0	1	
	⋮	⋮	⋮	⋮	⋮	⋮	⋮	⋮	⋮	⋮	⋮	⋮	⋮	⋮	⋮	⋮	⋮	⋮	⋮	⋮	⋮	⋮		
	Blue(253)	0	0	0	0	0	0	0	0	0	0	0	0	0	0	0	1	1	1	1	1	1	0	
	Blue(254)	0	0	0	0	0	0	0	0	0	0	0	0	0	0	0	1	1	1	1	1	1	0	
	Blue(255)	0	0	0	0	0	0	0	0	0	0	0	0	0	0	0	1	1	1	1	1	1	1	

Note (1) 0: Low Level Voltage, 1: High Level Voltage

6. INTERFACE TIMING

6.1 INPUT SIGNAL TIMING SPECIFICATIONS

The input signal timing specifications are shown as the following table and timing diagram.

Signal	Item	Symbol	Min.	Typ.	Max.	Unit	Note
Clock	Frequency	1/Tc	20	25.175	30	MHz	-
Vertical Active Display Term	Frame Rate	Fr	47	60	65	Hz	-
	Total	Tv	500	525	550	Th	Tv=Tvd+Tvb
	Display	Tvd	480	480	480	Th	-
	Blank	Tvb	20	45	70	Th	-
Horizontal Active Display Term	Total	Th	700	800	900	Tc	Th=Thd+Thb
	Display	Thd	640	640	640	Tc	-
	Blank	Thb	60	160	260	Tc	-
Input data Term	Setup time	Ts	7	--	--	ns	
	Hold time	TH	7	--	--	ns	
DE Term	Setup time	T _{SDE}	7	--	--	ns	
	Hold time	T _{HDE}	7	--	--	ns	

Note: Because of this module is operated by DE only mode, Hsync and Vsync input signals should be set to low logic level or ground. Otherwise, this module would operate abnormally.

INPUT SIGNAL TIMING DIAGRAM

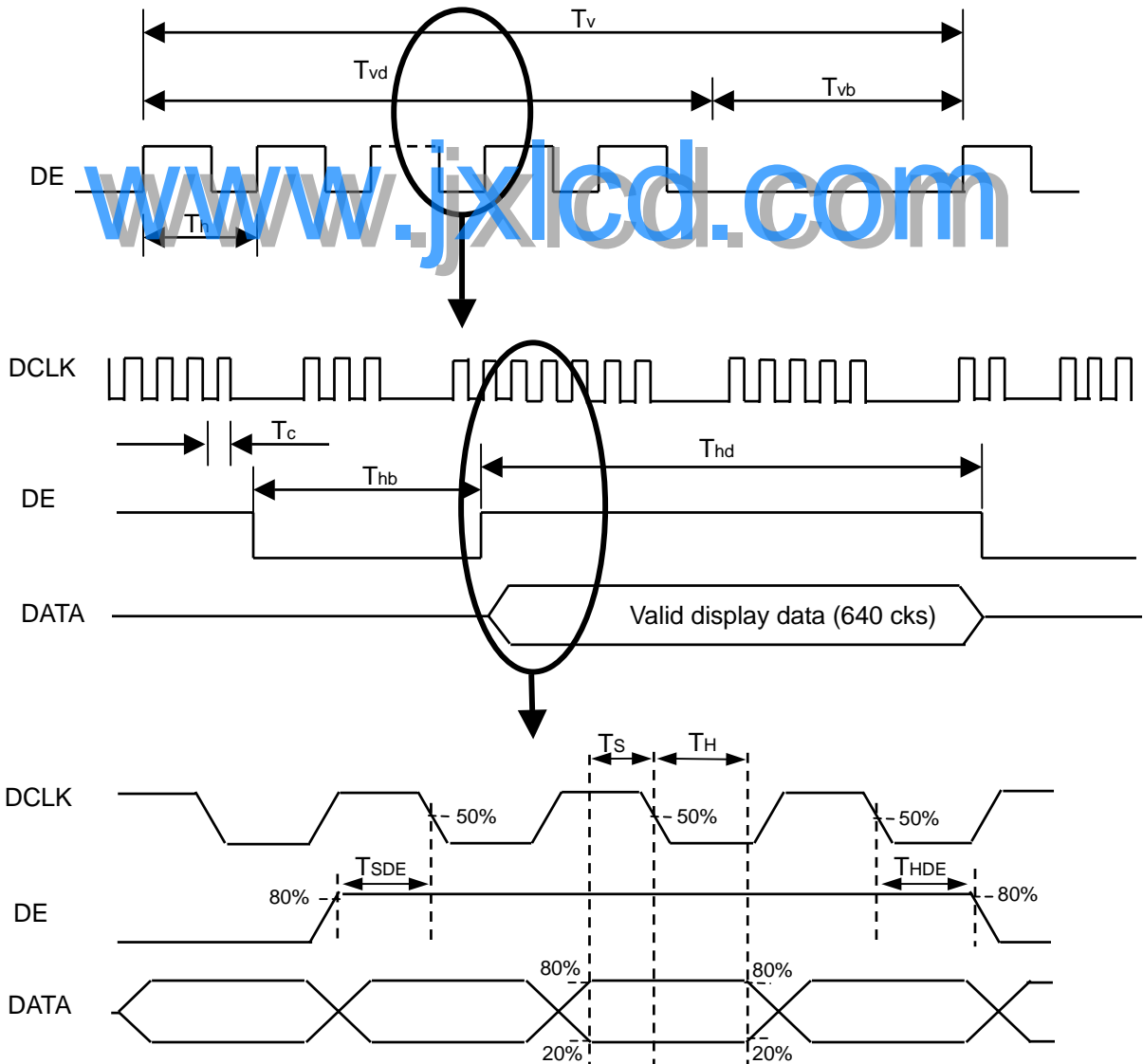

6.2 POWER ON/OFF SEQUENCE

To prevent a latch-up or DC operation of LCD module, the power on/off sequence should be as the diagram below.

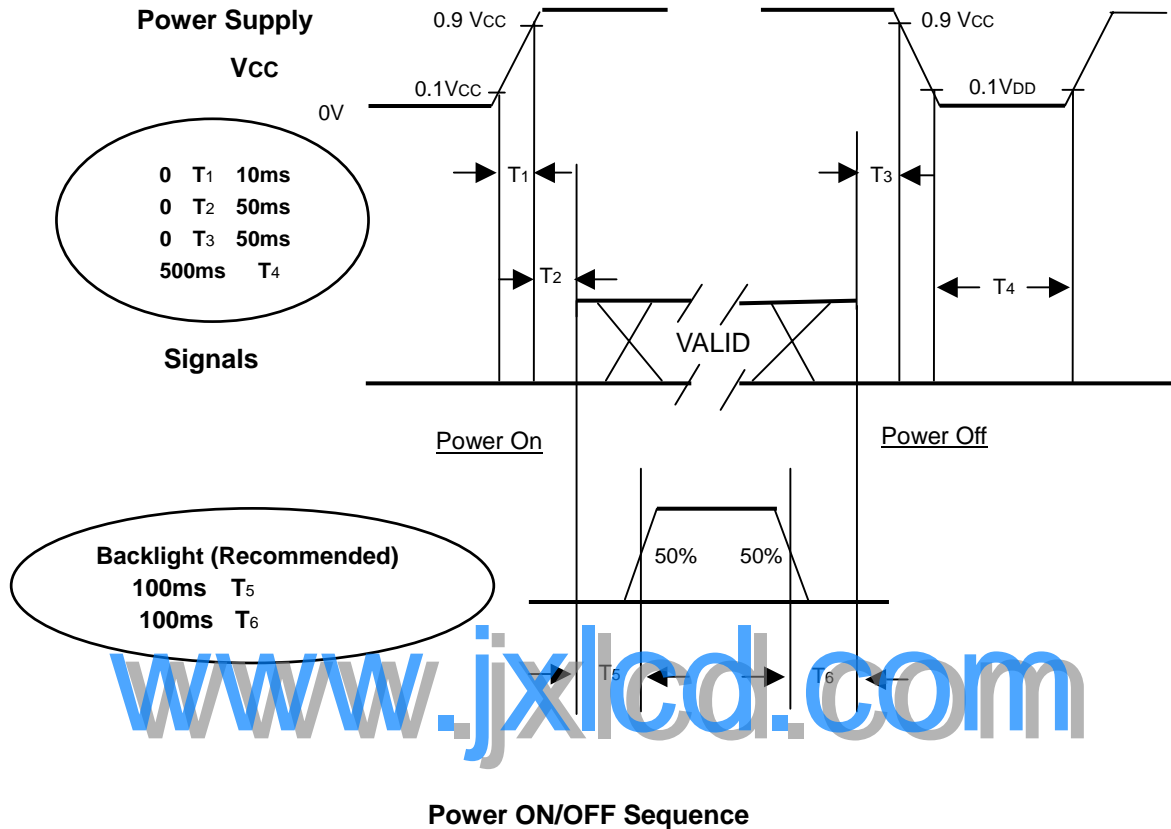

Note (1) The supply voltage of the external system for the module input should be the same as the definition of Vcc.

Note (2) Apply the lamp voltage within the LCD operation range. When the backlight turns on before the LCD operation or the LCD turns off before the backlight turns off, the display may momentarily become abnormal screen.

Note (3) In case of vcc = off level, please keep the level of input signals on the low or keep a high impedance.

Note (4) T4 should be measured after the module has been fully discharged between power off and on period.

Note (5) Interface signal shall not be kept at high impedance when the power is on.

7. OPTICAL CHARACTERISTICS

7.1 TEST CONDITIONS

Item	Symbol	Value	Unit
Ambient Temperature	T _a	25±2	°C
Ambient Humidity	H _a	50±10	%RH
Supply Voltage	V _{CC}	5.0	V
Input Signal	According to typical value in "3. ELECTRICAL CHARACTERISTICS"		
Inverter Current	I _L	4.2	mA
Inverter Driving Frequency	F _L	61	KHz
Inverter	DARFON / DELTA		

7.2 OPTICAL SPECIFICATIONS

The relative measurement methods of optical characteristics are shown in 7.2. The following items should be measured under the test conditions described in 7.1 and stable environment shown in Note (6).

Item	Symbol	Condition	Min.	Typ.	Max.	Unit	Note	
Contrast Ratio	CR	$\theta_x=0^\circ, \theta_y=0^\circ$ Viewing Normal Angle	450	600	-	-	Note(2)	
Response Time	T _R		-	15	25	ms	Note(3)	
	T _F		-	10	20	ms		
	Gray to gray			16.6	25		Note(4)	
Center Luminance of White	L _C		400	500	-	cd/m ²	Note(5)	
White Variation	δW		-	-	1.25	-	Note(8)	
Cross Talk	CT		-	-	4	%	Note(6)	
Color Chromaticity	Red		R _x	0.611	0.641	0.671	-	Color Chromaticity
	Green		R _y	0.300	0.330	0.360	-	
			G _x	0.236	0.266	0.296	-	
			G _y	0.568	0.598	0.628	-	
	Blue		B _x	0.114	0.144	0.174	-	
			B _y	0.038	0.068	0.098	-	
	White		W _x	0.242	0.272	0.302	-	
		W _y	0.248	0.278	0.308	-		
Color Gamut		72	75	-	%	NTSC		
Viewing Angle	Horizontal	θ _{x+}	80	85	-	Deg.	Viewing Angle	
		θ _{x-}	80	85	-			
	Vertical	θ _{y+}	80	85	-			
		θ _{y-}	80	85	-			

Note (1) Definition of Viewing Angle (θ_x, θ_y):

Viewing angles are measured by Eldim EZ-Contrast 160R

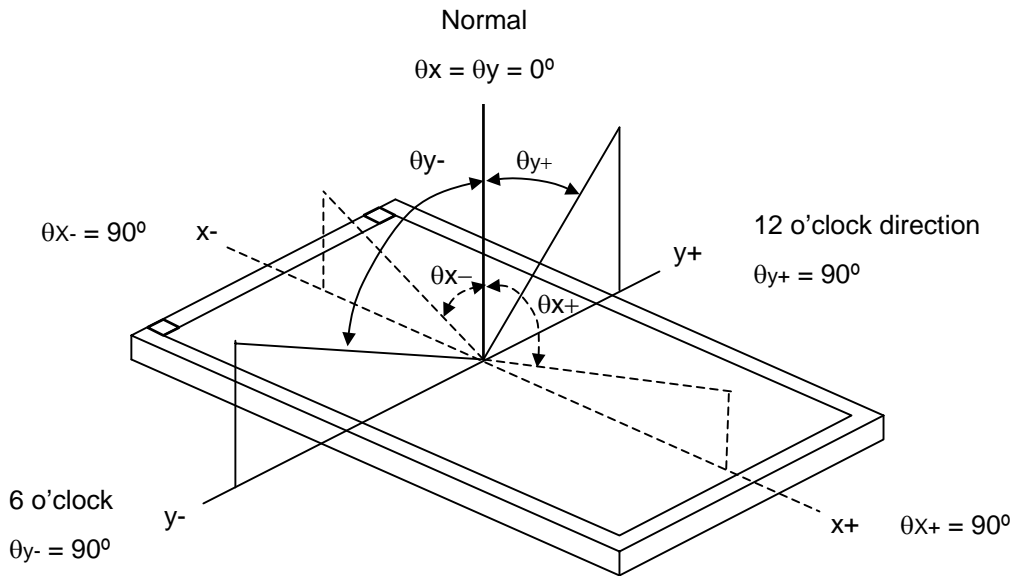

Note (2) Definition of Contrast Ratio (CR):

The contrast ratio can be calculated by the following expression.

$$\text{Contrast Ratio (CR)} = L_{255} / L_0$$

L_{255} : Luminance of gray level 255

L_0 : Luminance of gray level 0

$$\text{CR} = \text{CR} (5)$$

CR (X) is corresponding to the Contrast Ratio of the point X at the figure in Note (7).

Note (3) Definition of Response Time (T_R, T_F):

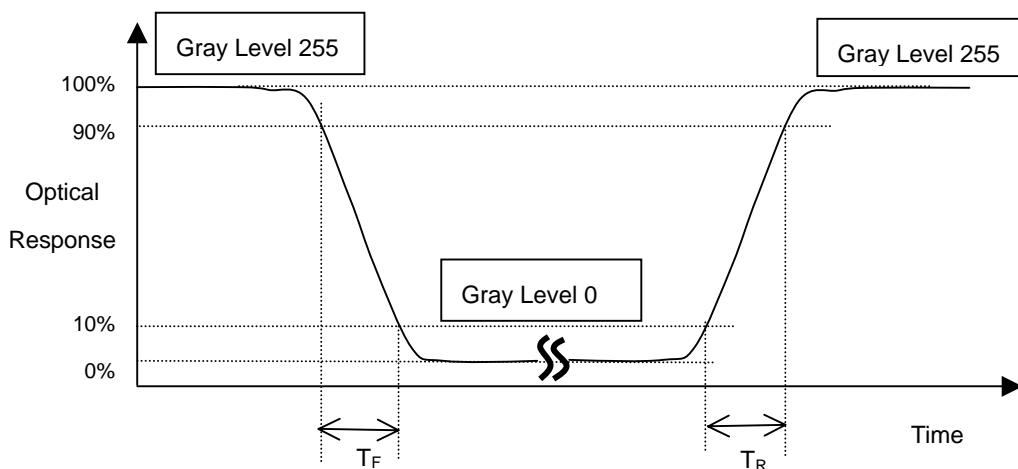

Note (4) Definition of Gray to Gray Switching Time:

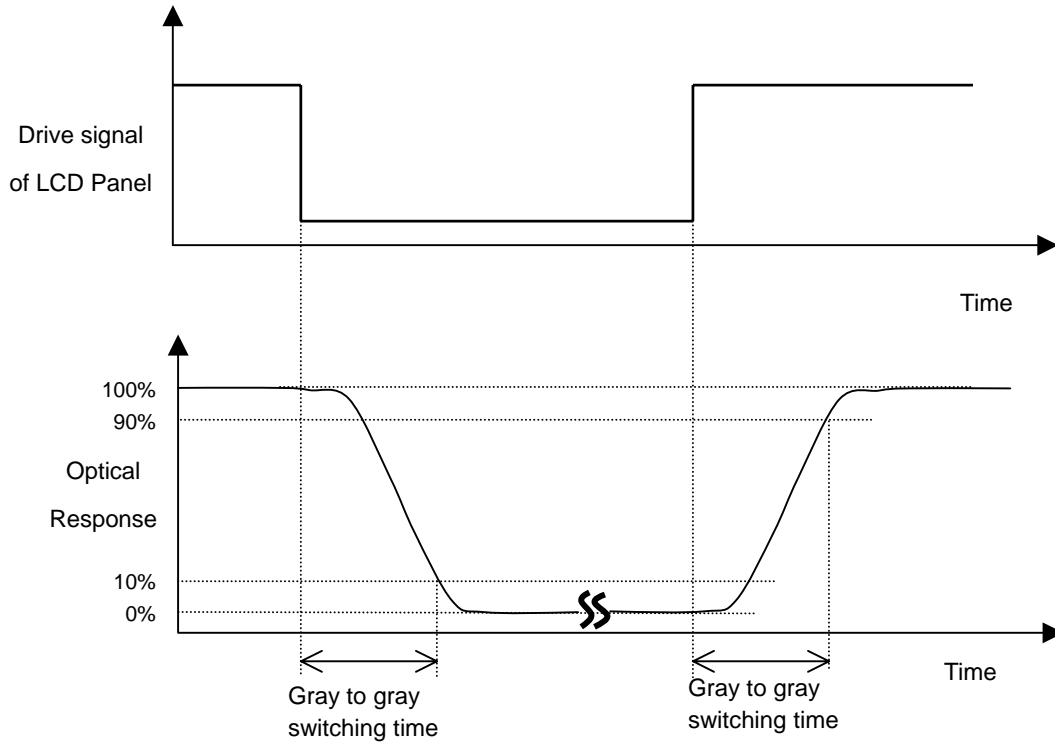

The driving signal means the signal of gray level 0, 63, 127, 191, 255.

Gray to gray value is optimized in NTSC video system. In other video system, video quality will depend on signal quality level.

Note (5) Definition of Luminance of White (L_C , L_{AVE}):

Measure the luminance of gray level 255 at center point and 5 points

$$L_C = L(5)$$

$$L_{AVE} = [L(1) + L(2) + L(3) + L(4) + L(5)] / 5$$

$L(x)$ is corresponding to the luminance of the point X at the figure in Note (7).

Note (6) Definition of Cross Talk (CT):

$$CT = |Y_B - Y_A| / Y_A \times 100 (\%)$$

Where:

Y_A = Luminance of measured location without gray level 0 pattern (cd/m^2)

Y_B = Luminance of measured location with gray level 0 pattern (cd/m^2)

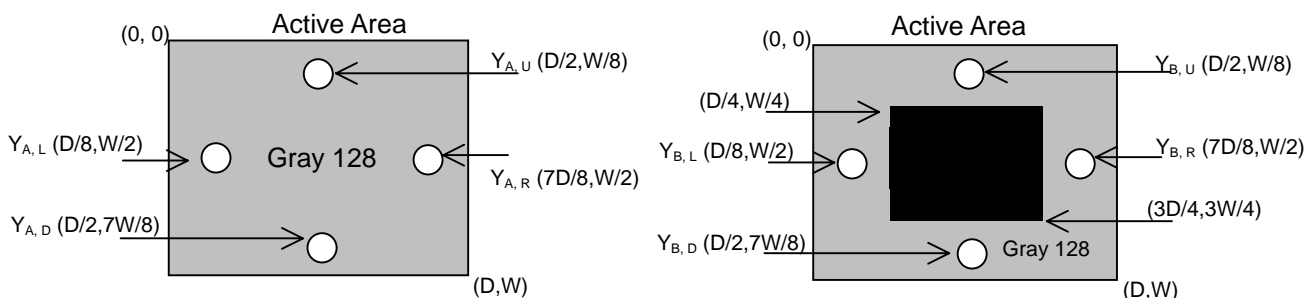

Note (7) Measurement Setup:

The LCD module should be stabilized at given temperature for 1 hour to avoid abrupt temperature change during measuring. In order to stabilize the luminance, the measurement should be executed after lighting Backlight for 1 hour in a windless room.

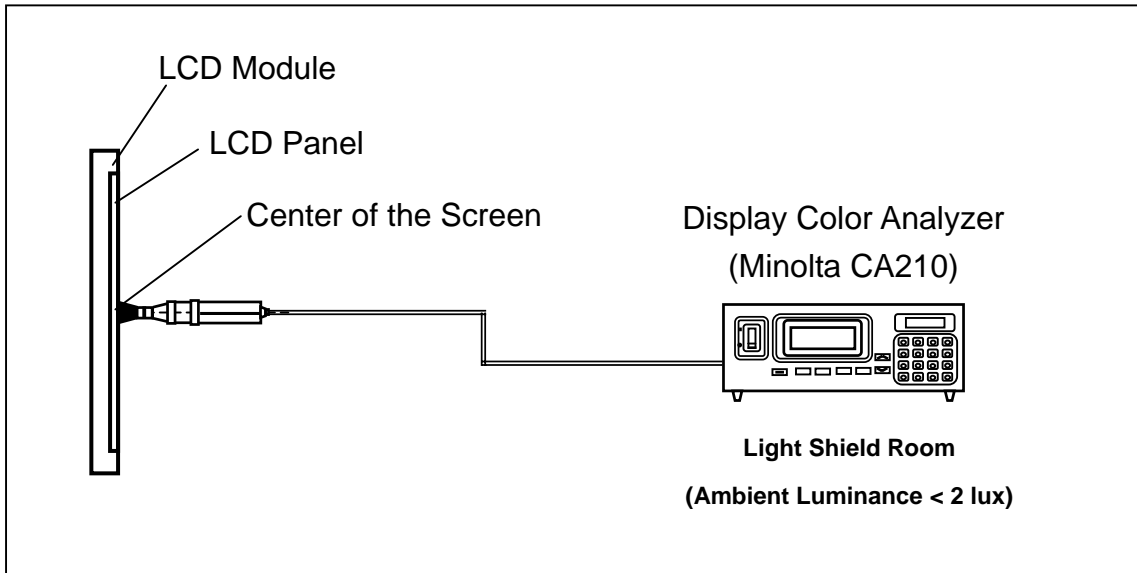

Note (8) Definition of White Variation (δW):

Measure the luminance of gray level 255 at 5 points

$$\delta W = \text{Maximum} [L(1), L(2), L(3), L(4), L(5)] / \text{Minimum} [L(1), L(2), L(3), L(4), L(5)]$$

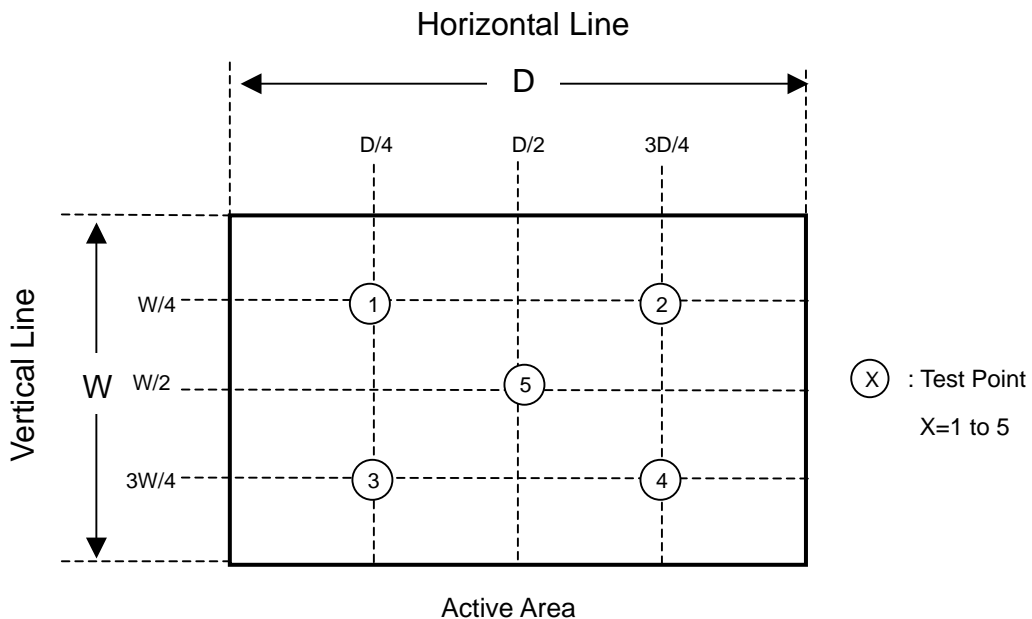

8. PACKAGING

8.1 PACKING SPECIFICATIONS

- (1) 5 TV LCD modules / 1 Box
- (2) Box dimensions : 535(L) X 357 (W) X 460 (H)
- (3) Weight : approximately 13Kg (5 modules per box)

8.2 PACKING Method

Figures 9-1 and 9-2 are the packing method

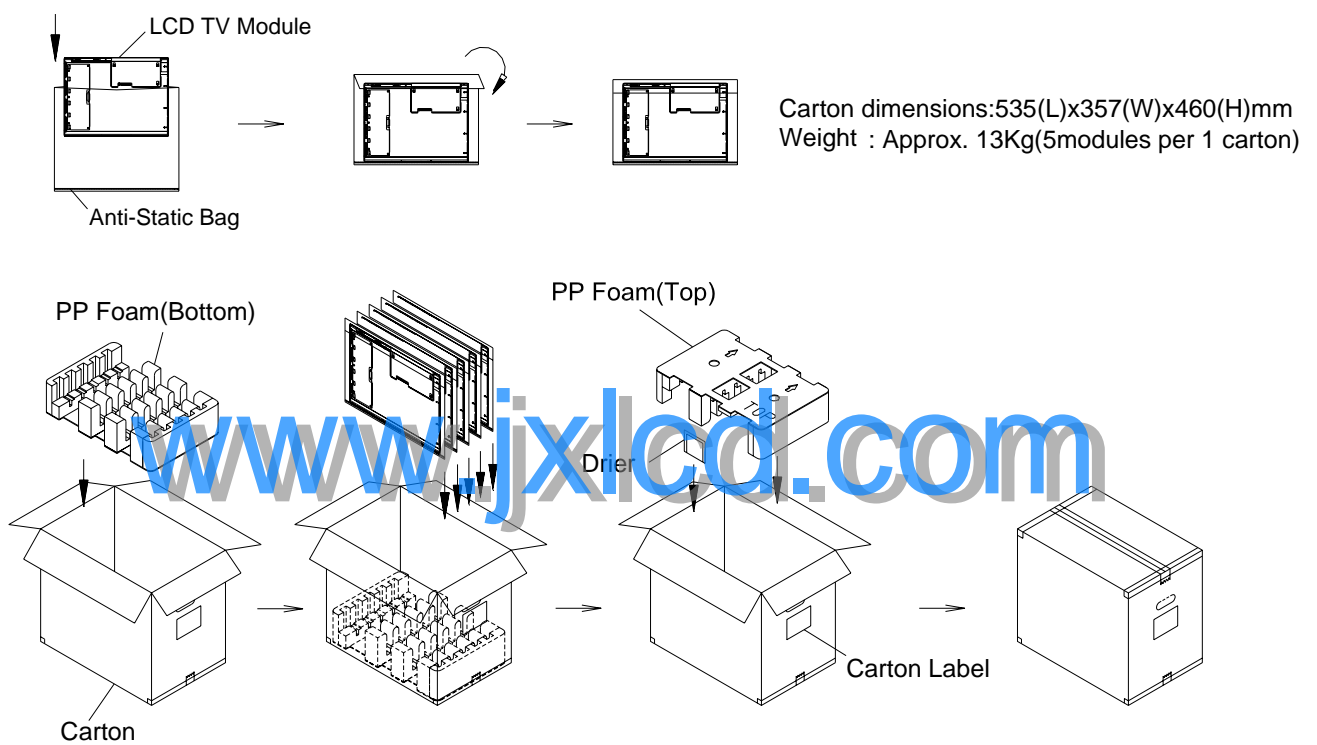
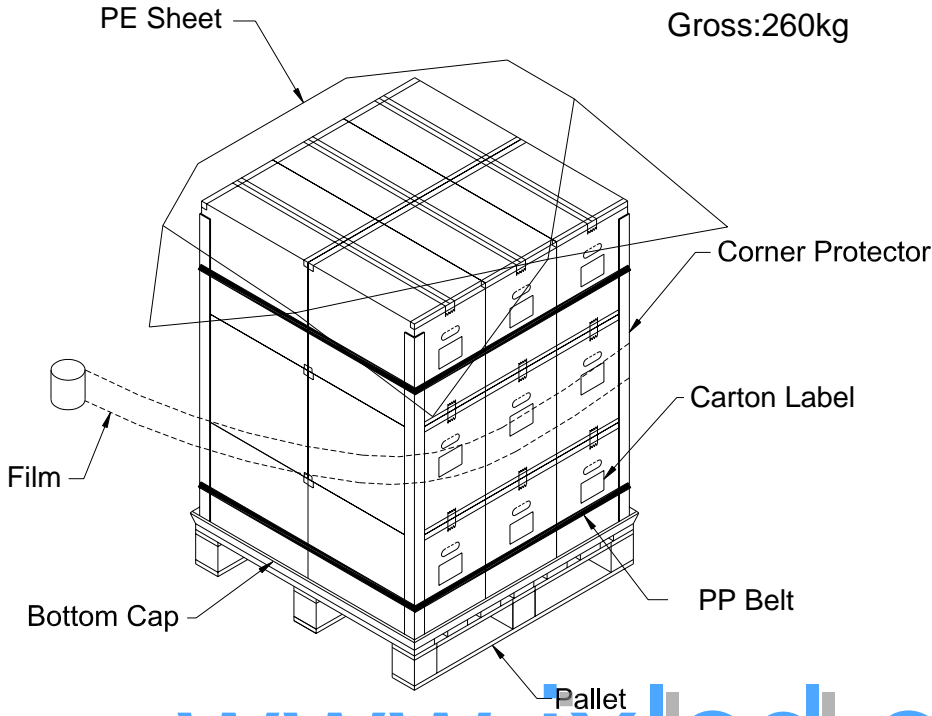

Figure.9-1 packing method

Corner Protector: L1350*50mm*50mm
Pallet: L1100*W1100*H135mm
Bottom Cap: L1100*W1100*H120mm
Pallet Stack: L1100*W1100*H1515mm
Gross: 260kg



www.jxlcd.com

Figure. 9-2 Packing method

9. DEFINITION OF LABELS

9.1 CMO MODULE LABEL

The barcode nameplate is pasted on each module as illustration, and its definitions are as following explanation.

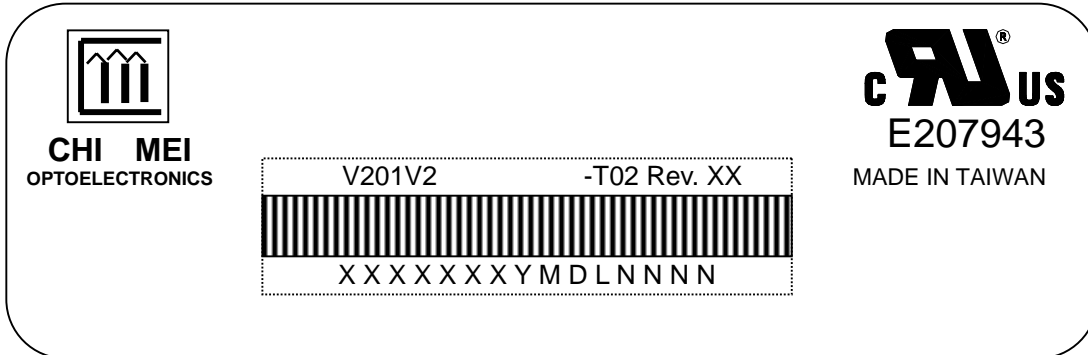

- (a) Model Name: V201V2-T02
- (b) Revision: Rev. XX, for example: A0, A1... B1, B2... or C1, C2...etc.
- (c) Serial ID: X X X X X X Y M D L N N N N

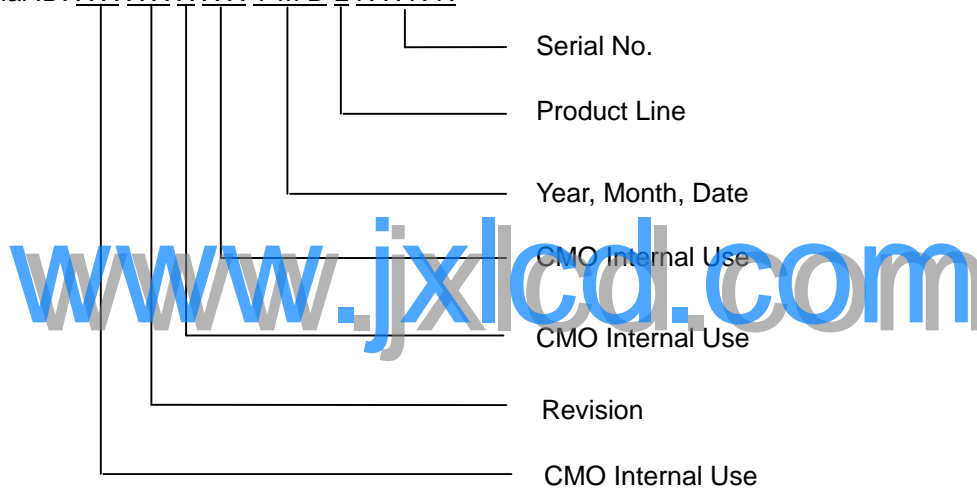

Serial ID includes the information as below:

- (a) Manufactured Date: Year: 0~9, for 2000~2009
 Month: 1~9, A~C, for Jan. ~ Dec.
 Day: 1~9, A~Y, for 1st to 31st, exclude I, O, and U.
- (b) Revision Code: Cover all the change
- (c) Serial No.: Manufacturing sequence of product
- (d) Product Line: 1 -> Line1, 2 -> Line 2, ...etc.

10. PRECAUTIONS

10.1 ASSEMBLY AND HANDLING PRECAUTIONS

- (1) Do not apply rough force such as bending or twisting to the module during assembly.
- (2) It is recommended to assemble or to install a module into the user's system in clean working areas.
The dust and oil may cause electrical short or worsen the polarizer.
- (3) Do not apply pressure or impulse to the module to prevent the damage of LCD panel and Backlight.
- (4) Always follow the correct power-on sequence when the LCD module is turned on. This can prevent the damage and latch-up of the CMOS LSI chips.
- (5) Do not plug in or pull out the I/F connector while the module is in operation.
- (6) Do not disassemble the module.
- (7) Use a soft dry cloth without chemicals for cleaning, because the surface of polarizer is very soft and easily scratched.
- (8) Moisture can easily penetrate into LCD module and may cause the damage during operation.
- (9) High temperature or humidity may deteriorate the performance of LCD module. Please store LCD modules in the specified storage conditions.
- (10) When ambient temperature is lower than 10°C, the display quality might be reduced. For example, the response time will become slow, and the starting voltage of CCFL will be higher than that of room temperature.

10.2 SAFETY PRECAUTIONS

- (1) The startup voltage of a Backlight is approximately 1000 volts. It may cause an electrical shock while assembling with the inverter. Do not disassemble the module or insert anything into the Backlight unit.
- (2) If the liquid crystal material leaks from the panel, it should be kept away from the eyes or mouth. In case of contact with hands, skin or clothes, it has to be washed away thoroughly with soap.
- (3) After the module's end of life, it is not harmful in case of normal operation and storage.

10.3 SAFETY REGULATION

- (1) V201V2 is certified with Safety Regulation UL6500. File E240708, Volume 1.
- (2) V201V2 is certified with Safety Regulation IEC 60065. Ref. Certif. No: JPTUV-007772.

11.MECHANICAL CHARACTERISTICS

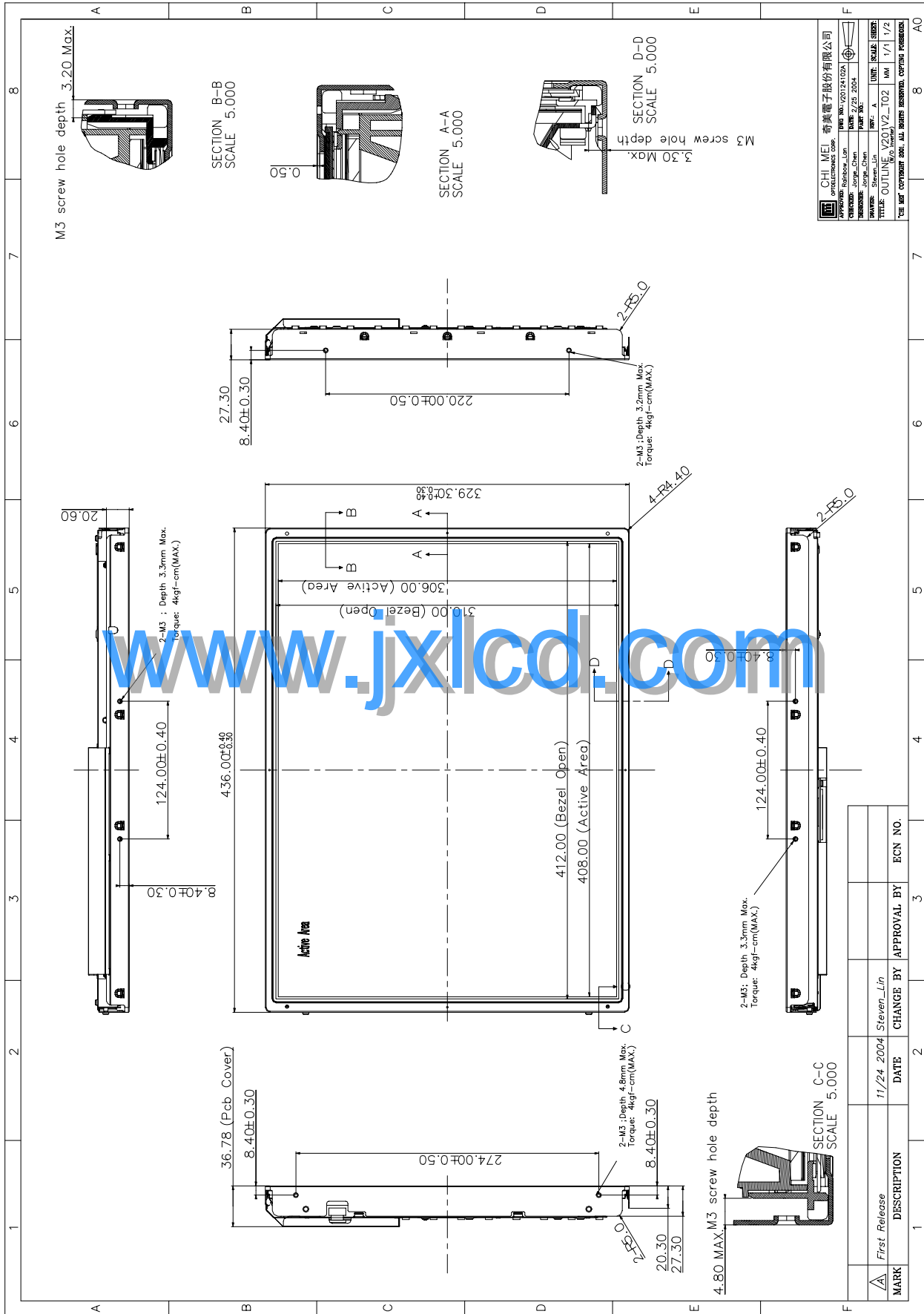

CHI MEI 奇美電子股份有限公司	DATE: 11/24/2004	UNIT: MM	SCALE: 1/1	SHEET: 1/2
APPROVED: Steven_Lin	DATE: 11/24/2004	UNIT: MM	SCALE: 1/1	SHEET: 1/2
DESIGNED: Steven_Lin	DATE: 11/24/2004	UNIT: MM	SCALE: 1/1	SHEET: 1/2
CHECKED: Steven_Lin	DATE: 11/24/2004	UNIT: MM	SCALE: 1/1	SHEET: 1/2
TITLE: OUTLINE V201V2-T02				
TUT NOT CORRECT ONE. ALL RIGHTS RESERVED. COPYRIGHTS RESERVED.				

MARK	DESCRIPTION	DATE	CHANGE BY	APPROVAL BY	ECN NO.
A	First Release	11/24/2004	Steven_Lin		

