

General

The X-ray thickness gage is used to measure the thickness of a strip continuously without contacting that strip. This gage uses the fact that the amount of radiation that passes through the strip varies with the thickness of that strip.

The TOSGAGE-7525 is a high quality thickness gage for cold rolling achieving outstanding safety, operability, accuracy and cost-performance developed over many years. It has the following features.

- Noise immunity is improved by digitizing the signals between the measuring head and the equipment cabinet.

- The operation-PC uses Windows® NT, and is a user-friendly PC.
- A newly-developed X-ray generator is used, providing extremely accurate measurement results with a quick response time. The TOSGAGE-7525 focuses X-ray beams finely in the strip width direction to improve thickness resolution in the strip width direction, and making it suited to measuring the shape of the section of measured materials.

The TOSGAGE-7525 can also be used as a AGC backup for when the fixed thickness gage (TOSGAGE-7521/7522) has failed.

Configuration

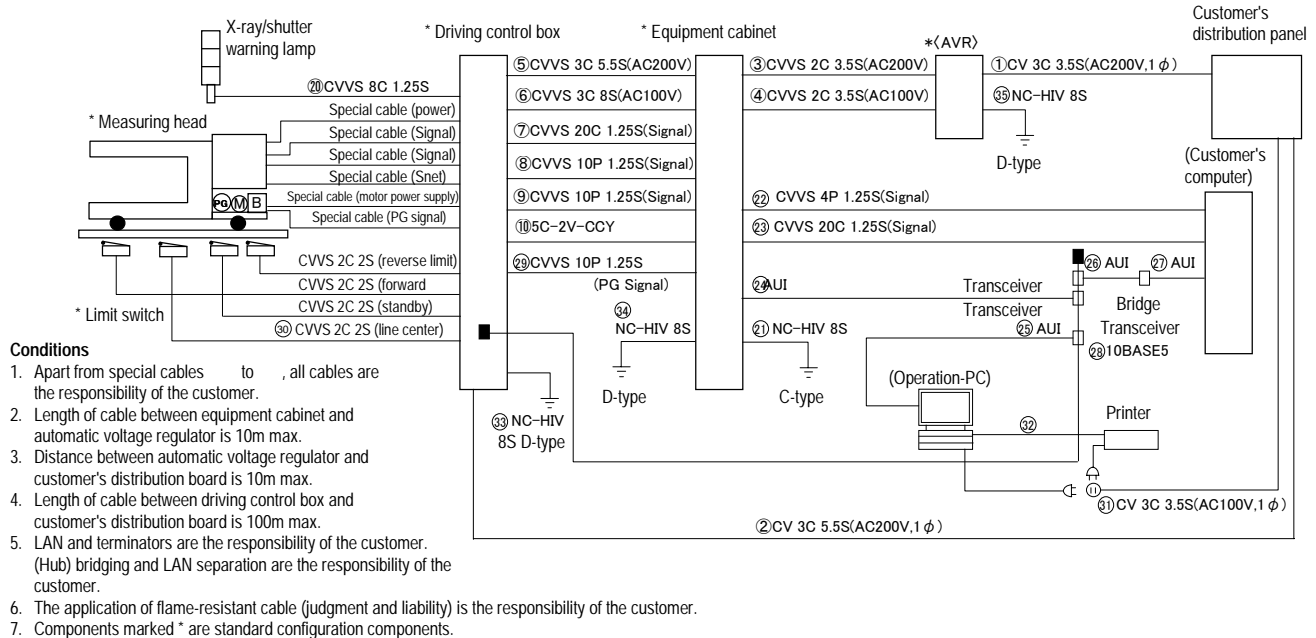

Figure 1 Configuration and Cable Connections

1. Standard Configuration

Measuring head	1
Equipment cabinet	1
Operation-PC	1
Automatic voltage regulator	1
Driving control box (also used as a junction box)	1
Standard accessories	1 set
Safety valve	(1)
Flow switch	(1)
Limit switches	(4)
Sample holder	(1)
Cable ducts	(1 set)
Special cable (20 m)	(1 set)
Hose (20 m)	(1 set)
Standard spare parts	(1 set)
Fuses/lamps	1 set

2. Optional Configuration

Measuring head peripheral equipment	
Rails	
Rack and rack mounting plate	
Hanger	
Hanger rails	
Test samples	
X-ray/shutter warning lamps 1 set (red/green)	

Piping parts

Air filter
Strainer
Reducing valve (for air)
Reducing valve (for nitrogen)
Nitrogen escape valve
Nitrogen cylinder
Air dryer
Cooling water supply unit
Oil mist separator
Flow rate gage (for cooling water)
Pressure switch (for air)
Pressure switch (for nitrogen)
Valve stand

Interface (for PI/O interface with purchaser's PC)

Indicator/recorder	
Wide angle indicator (110°)	
Recorder (hybrid-type)	

Cabinet (houses control panel, recorder, etc.)

Cables	Various types
Hoses	Various types

Accessories

Maintenance PC
Operation-PC printer

17-type monitor

Transceiver (with cables)

X-ray/shutter warning lamps (for three lamps)

3. Individual Unit Configuration

Measuring head

The C-Frame can be broadly divided into the X-ray generator, standard changer, and detector. Each component is an individual unit and can be replaced easily.

<Main components>

C-Frame

(standard: measuring air gap height 750mm, depth 2500mm)

X-ray generator

Generator control power supply

Standard changer

Detector (ionization chamber)

Ionization chamber power supply

C-Frame carriage drive unit (AC motor)

Air purge nozzle

Safety valve

Flow switch

DC power supply unit (+5V, +24V)

Cable duct

Air cooler

Driving control box (also used as junction box)

This is integrated with junction box of the past, so it features the necessary control display on the machine side.

<Main components>

Driving control box

X-ray and shutter ON/OFF switch

X-ray interlock

C-Frame carriage drive unit

Carriage forward/reverse/stop switch

Shutter and carriage drive interlock

Control location selection switch (local, remote)

Equipment cabinet

The FA control computer (V300) was developed for industrial measurement and control. It is a computer that features reliability and expandability (utilizes a VME bus).

<Main components>

- Equipment cabinet
- FA computer (V300)
- DC power supply unit (+24V)
- Circuit breaker (100V AC single phase)
- Circuit breaker (200V AC single phase)
- Isolated amplifier (for deviation output)

Operation-PC

Uses FA computer to display different kinds of settings, self-diagnosis and deviation trends. Communications are carried out via the microcomputer and Ethernet, settings are carried out via a microcomputer, and status detection information is sent and received.

<Main components>

- FA3100 main unit (Windows® NT)
- 15-type color monitor
- Keyboard
- Mouse
- Ethernet board
- Standard software package

Automatic voltage regulator

This is used to stabilize the power supply provided to the main unit of the thickness gage. Specify frequency of either 50 Hz or 60 Hz.

- Input** 200/220V AC ± 10%, 1φ
(100/110V AC is also possible)
- Output** 200V AC (0.8KVA), 1φ
100V AC (0.7KVA), 1φ
- Distortion** 5% max., capacity 1.6kVA

Special Cables

Special cable between driving control box and measuring head (20m).

Hoses

Special hose between customer's piping and measuring head (20m).

- Cooling water hose (neoprene, 3/4B)
- Air purge hose (neoprene, 1/2B, 3/4B)
- Nitrogen hose (neoprene, 1/4B)

Standard spare parts

- Fuses** 0.5A, 3A, 5A
- Lamps** 40W

Measuring head peripheral equipment

- X-ray/shutter warning lamp
- Limit switches

Documents

Contract Specifications	5 copies
Contract Drawings	5 copies
Test Report	5 copies
Operation Manual (including maintenance)	5 copies
Schematic Diagram	5 copies

Operating Principle

When the X-rays emitted from the X-ray generator pass through the material being measured, they are scattered and absorbed by that material. The X-rays that pass through the material are received by the detector (ionization chamber) and are converted into electrical signals (ionization current) proportional to the quantity of X-rays. These signals are subjected to A/D conversion at the integrated A/D converter before being sent to the microcomputer by the high-speed serial interface.

At the equipment cabinet, these signals are calculated by the microcomputer and then output as thickness signals.

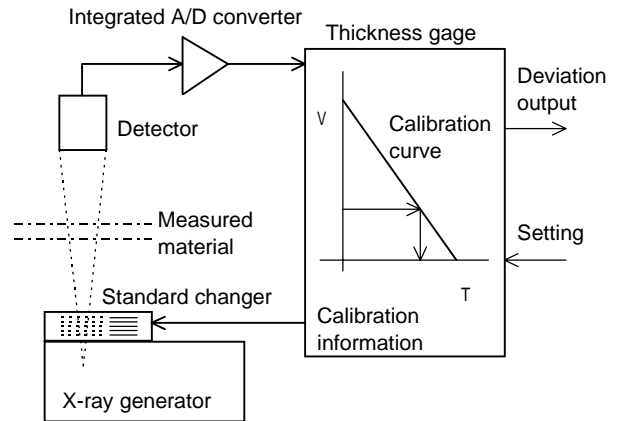

Figure 2 Operating Principle

Measurement Method

The TOSGAGE-7525 is a single-beam thickness gage that uses previously calibrated standard plates to create and store a calibration curve throughout the entire measurement range. The signals detected for the X-rays that have passed through the measuring material during measurements are applied to the calibration curve to derive the thickness.

As shown in the sample calibration curve shown below (Figure 3), the measurement range is divided into several individual measurement ranges. The calibration curve is expressed as a combination of the individual calibration curves in each measurement range.

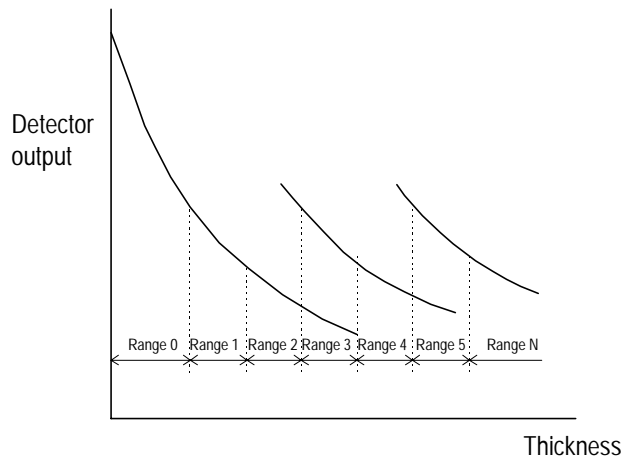

Figure 3 Calibration Curve

The X-ray generator, detector and other electrical circuits on the X-ray thickness gage are subject to drift as time passes, so the gage must be calibrated at periodical intervals. Two calibration methods are used for this purpose: Full calibration (in which all calibration curves in the entire measurement range are recreated) and Calibration (in which the calibration curve in only one measurement range is recreated). Full calibration requires about two minutes and calibration requires about five seconds. This combination of two calibration methods is a unique Toshiba innovation unlike the methods used by any other company. As the calibration curve is created by predetermined calibration points, Full calibration can be performed regardless of settings.

Using these two calibration methods, it is possible to, for example, perform Full calibration two to three times daily to maintain the measurement accuracy in the measurement range, and perform calibration near the nominal thickness during the short period of time when no strip is present in the X-ray beam (such as during coil changing, etc.) to eliminate drift. This allows setup to be performed with great precision when the strip is present in the X-ray beam.

When the calibration curve is created, standard plates are automatically inserted, the detector output is read in and the calibration data is calculated and stored in the microcomputer

memory. During measurement, the detector output is read in and then the thickness is calculated from the stored calibration curve and output in the form of analog or digital signal.

The microcomputer has a state-of-the-art 32-bit microprocessor for high-speed calculations.

Specifications

General Specifications

Measured materials: Mild steel strip

Measurement range: 1.00 to 16.00mm
(0.85 to 17.92mm pure steel equivalent)

Range for setting compensation:
± 15.00% (based on pure steel)

Setting accuracy:
± SQRT [(linearity)² + (reproducibility)² + (noise)²]

This is the accuracy when a test sample for accuracy test is used offline.

Measuring air gap height of 750mm and time constant of 30ms.

Linearity: Max. ± 0.1% of set thickness (2σ)

Reproducibility:
Max. ± 0.05% of set thickness or ± 0.05μm, whichever is greater (2σ)

Noise:

Thickness(mm)	Noise(%)
1 to 7.99	Max. ± 0.12%
8 to 13.99	Max. ± 0.20%
14 to 15.99	Max. ± 0.24%

(1.65)

Drift:

Max. ± (0.2% of set thickness + 0.5μm)/8h

Measuring head

Changes in air density to max. cooling water temperature variations ± 3°C and max. temperature variations around measuring head ± 5°C are not included.

Max. temperature variations around equipment cabinet/driving control box ± 5°C.

Response time:

Max. 30ms (response 63% when thickness of 2mm is changed in 100μm increments)

Calculation period: 10ms

Calibration time:

For full calibration Max. 150s

For calibration Max. 5s

For setup Max. 20ms

(Does not include writing time for settings, however)

Warm-up time:

1 hour or less from cold start

(Time taken for measuring to become possible after switching the power from OFF to ON)

0.5 hour or less from X-ray ON

(Time taken for measuring to become possible after switching the X-ray from OFF to ON)

Measuring air gap:

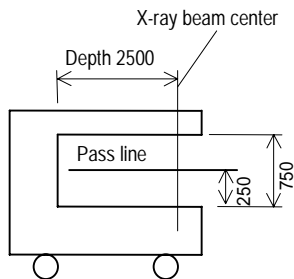

Edges of measured material:

Measurement of X-rays received by detector

(Edge) Measurement Method

Plate edge measurement accuracy:

Max. $\pm 1\text{mm}$

(Max. 100mm/s for carriage speed)

Carriage drive system: Inverter speed control

(Standard is 2-level selection: 30 and 100mm/s)

Carriage position measuring accuracy

(Reproducibility): Max. $\pm 1\text{mm}$

Allowable ambient temperature:

Measuring head

Designed to be suitable for strip temperature 1200°C .

Equipment cabinet/driving control box

0 to 40°C

(no condensation)

Operation-PC

5 to 35°C

(no condensation)

Power:

For main unit (instrument)

200V AC $\pm 10\%$, 50/60Hz, 2kVA single phase (100V AC can also be supported by an optional transformer)

For motorized carriage

200V AC $\pm 10\%$, 50/60Hz, 1kVA single phase

For operation-PC

100V AC $\pm 10\%$, 50/60Hz, 1kVA single phase

Cooling water:

Pure water or tap water passed through a 40 mesh filter

Pressure: 0.2 to 0.5Mpa

Flowrate: 10litter/min

Temperature: $25^{\circ}\text{C} \pm 10^{\circ}\text{C}$

(however, change in water temperature in one day shall be $\pm 3^{\circ}$ max.)

Tap water or filtrated industrial water

Pressure: 0.2 to 0.5Mpa

Flowrate: 30litter/min

Temperature: $25^{\circ}\text{C} \pm 10^{\circ}\text{C}$

Air:

Purified air containing no oil mist, that has been passed through a $10\mu\text{m}$ filter

Pressure: Approximately 0.6 to 0.7Mpa

Flowrate: 1.5m^3 [normal]/min

Temperature: $25^{\circ}\text{C} \pm 10^{\circ}\text{C}$

Nitrogen gas:

Pressure: Approximately 0.02Mpa

Purity: 99.99% min.

Cables:

Total length from measuring head to driving control box to equipment cabinet is 150m max.

Ground:

Less than 10 for circuit

Less than 100 for safety

Radiation leakage:

Max. $2.5\mu\text{SV/h}$ at surface of X-ray generator cover with shutter closed

Color: Toshiba standard paint color

Measuring head Heat-resistant paint (gray)

Equipment cabinet Munsell 5Y7/1

Operation-PC Manufacturer's standard color

Automatic voltage regulator Munsell 5Y7/1

Driving control box Munsell 5Y7/1

Indicator frame Munsell N1.5

Recorder frame Manufacturer's standard color

Others Manufacturer's standard color

Functional Specifications

Item	Standard Specifications	Special Order Specifications	Remarks
Setting location (Thickness setting, compensation setting, calibration, setup instruction, etc.)	Operation-PC	Purchaser's computer Equipment cabinet (maintenance-PC)	
Settings			
Thickness setting	7 digits mm	6 to 9 digits to mm	Up to 9 digits can be set mm
Compensation setting	4 digits with \pm sign \pm (%)	Code compensation Setting range 0 to 999	Code compensation consists of one of the following two types: (code) (compensation 1) (compensation 2) 20 +15% -15% 500 0% 0% 980 -15% +15%
Material code	2 digits		Select either one of material code or steel type code
Steel type code	2 digits		
Offgauge setting	3 bands	5 bands μm setting (μm) % setting (%) % setting (%)	
Strip width	Max. 5 digits mm		
Coil no.	Max. 16 digits (letters and numbers)		
Coil weight	None	Max. 6 digits (kg)	
Coil length	None	Max. 6 digits (m)	
Pass angle compensation	No compensation (pass angle 0°)	1 type; angle fixed	
Preset value	None	Up to 16 passes	
Calibration/Setup instruction	External (operation-PC) Full calibration Calibration (Setup + range calibration) Setup	External (purchaser's computer) Full calibration Calibration Setup Equipment cabinet (maintenance-PC)	
Deviation range selection	None	2-step changing by purchaser's computer Automatic changing (according to thickness setting)	
Deviation range value	Set to any value on operation-PC	Set to any value on purchaser's computer	1 μm unit
Time constant selection	0.01 second	Automatic changing (according to thickness setting)	
Time constant value	Set to any value on operation-PC	Set to any value on purchaser's computer	1ms unit
% deviation range selection	None	2-step changing by purchaser's computer Automatic changing (according to thickness setting)	
% deviation range value	None	Set to any value on operation-PC Set to any value on purchaser's computer	1% unit

Output Specifications

1. Standard Specifications

Item	Standard Specifications	Special Order Specifications	Remarks
Analog deviation output (μm or %)	For control 1 insulated output (AGC/purchaser's computer, etc.) 4 to 20 mA/maximum deviation range	For control $\pm 10\text{V}$ / max. deviation range For indicator/for recorder $\pm 10\text{V}$ / each deviation range	
Gage healthy (HEL) output	AND conditions shown below: X-ray ON Shutter open Not test mode Not initial mode Automatic mode Open collector output	AND conditions for standard specifications and user specifications	
Self-diagnostics	Displayed on operation-PC	Printer output from operation-PC	

2. Optional Specifications

PI/O input and output in addition to the standard specifications listed above is possible by installing an interface with an optional configuration.

Item	Standard Specifications	Special Order Specifications	Remarks
Settings Thickness Compensation Strip width	BCD 1 system Open collector Maximum load 24V DC, 50mA	BCD 1 system No-voltage relay contact Maximum load 48V DC, 0.1A	
Self-diagnostics	(1) Status output * Abnormal * Warning Open collector Maximum load 24V DC, 50mA	(1) Code output BCD 3 digits (2) Status output * Unmeasurable * Full calibration request Both (1) and (2) open collector or no-voltage relay contact	
Digital deviation output	None	14-bit binary output with +/- sign ± 16000 maximum deviation range Open collector output Maximum load 24V DC, 50mA	Output period 0.01 second
Digital absolute output	None	Max. 6 digits mm Open collector output Maximum load 24V DC, 50mA	Output period 1 second Can be changed in 0.01 second increments

Profile Measurement Specifications

1. Measurement Mode

Item	Scanning Pattern	Standard Specifications
Full-width profile scanning		In this mode the carriage is made to scan in a strip width direction by a start profile measurement command, thereby measuring the whole width profile. The speed of the carriage is 30mm/s on both edges, and 100mm/s at the center.
Edge profile scanning		In this mode the carriage is made to scan in a strip width direction by a start profile measurement command, thereby measuring the edge profile. WS (or DS) edge distance is set beforehand from the customer's computer.
Center measurement		This mode measures the center of the strip continuously in a longitudinal direction. It is used as backup for AGC thickness gages (center measurement).

2. Data Processing

The profile data processing shown below is carried out, and it is displayed on the operation-PC.

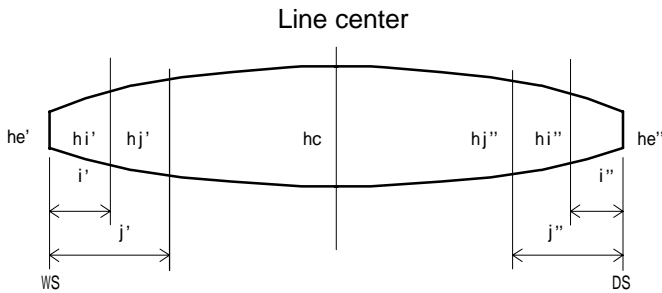

Figure 4 Section in Strip Width Direction

Note:

- Edge distance settings i' , i'' , and j' , j'' are the same.
- i can be set from 5 to 50mm (i can be set at 5 locations)
- j can be set from 50 to 100mm (edge drop standard)
- $i < j$ (in these specifications the initial settings are $i = 25\text{mm}$, $j = 75\text{mm}$.)

1) Crown Value

Crown value, WS crown value, DS crown value are calculated from the measurements of center plate thickness, WS side specified measurement points and DS side specified measurement points.

Crown values are calculated as follows:

- Crown value: $chi = hc - (hi' + hi'')/2$
- WS crown value: $chi' = hc - hi'$
- DS crown value: $chi'' = hc - hi''$

2) Wedge Value

Wedge value is calculated from the measured thickness at WS side specified measurement points and DS side specified measurement points.

The formula for calculation is shown below.

$$Whi = hi'' - hi'$$

3) Edge Drop Amount

Edge drop amount is calculated from the measured width between two points specified on the WS side and DS side.

Calculations are made as follows.

- WS edge drop amount: $eh' = hj' - hi'$
- DS edge drop amount: $eh'' = hj'' - hi''$

Example of Display on Operation-PC Screen

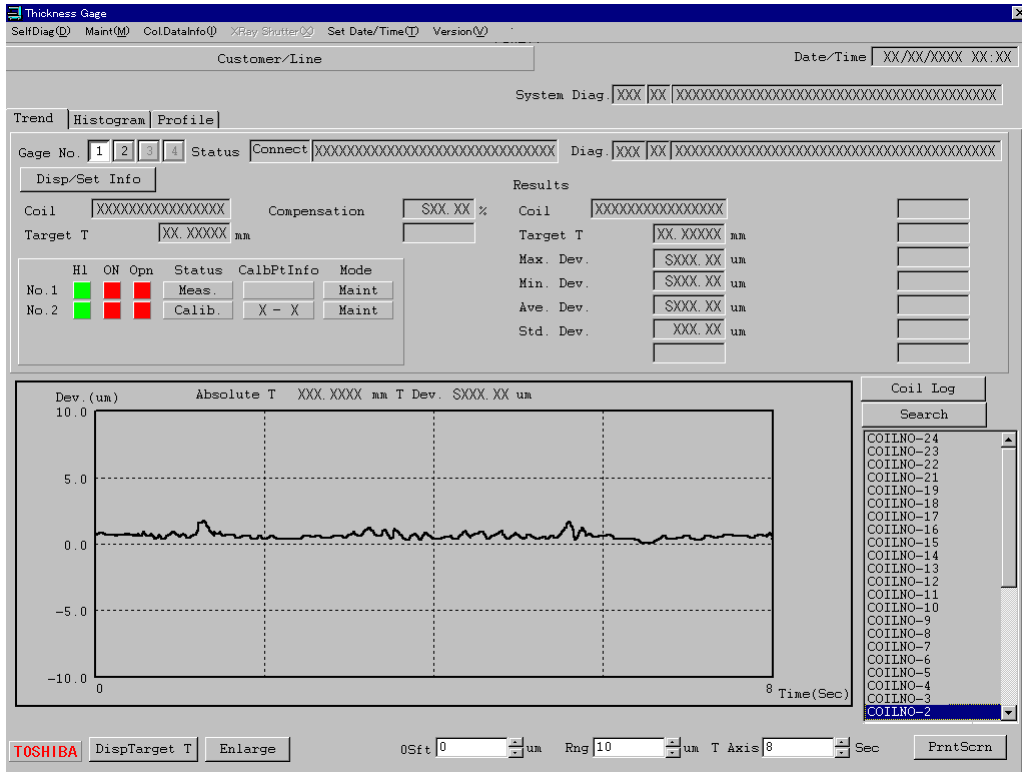

Figure 5 Thickness Deviation Trend Screen

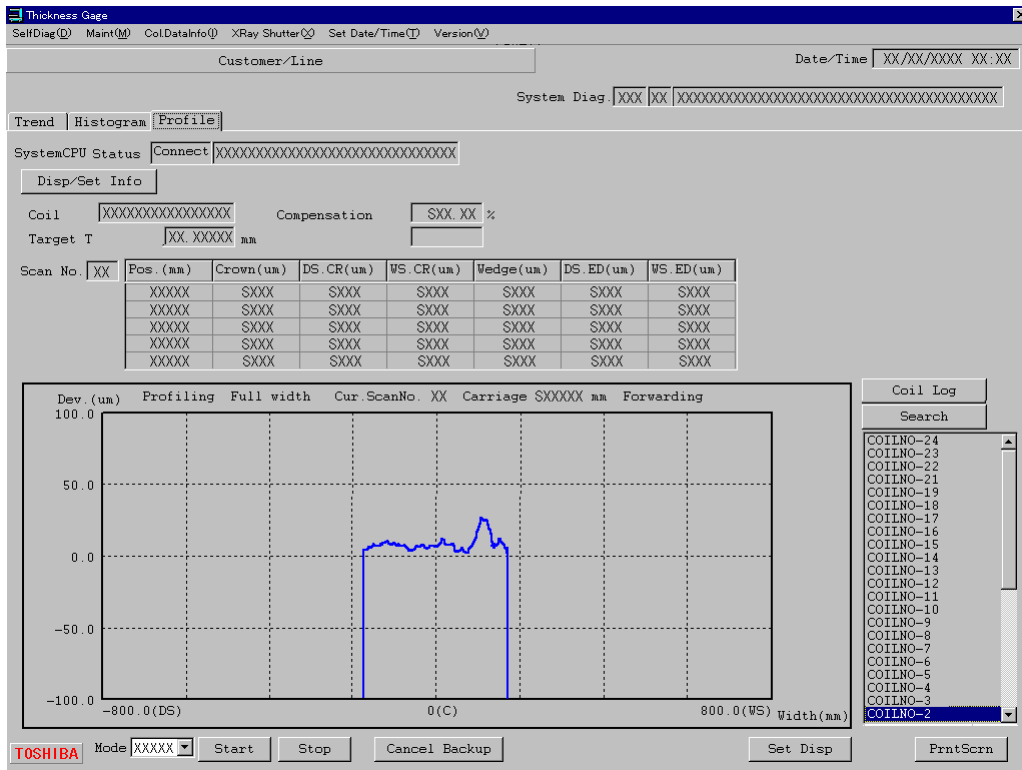

Figure 6 Thickness Deviation Profile Screen

External Dimensions

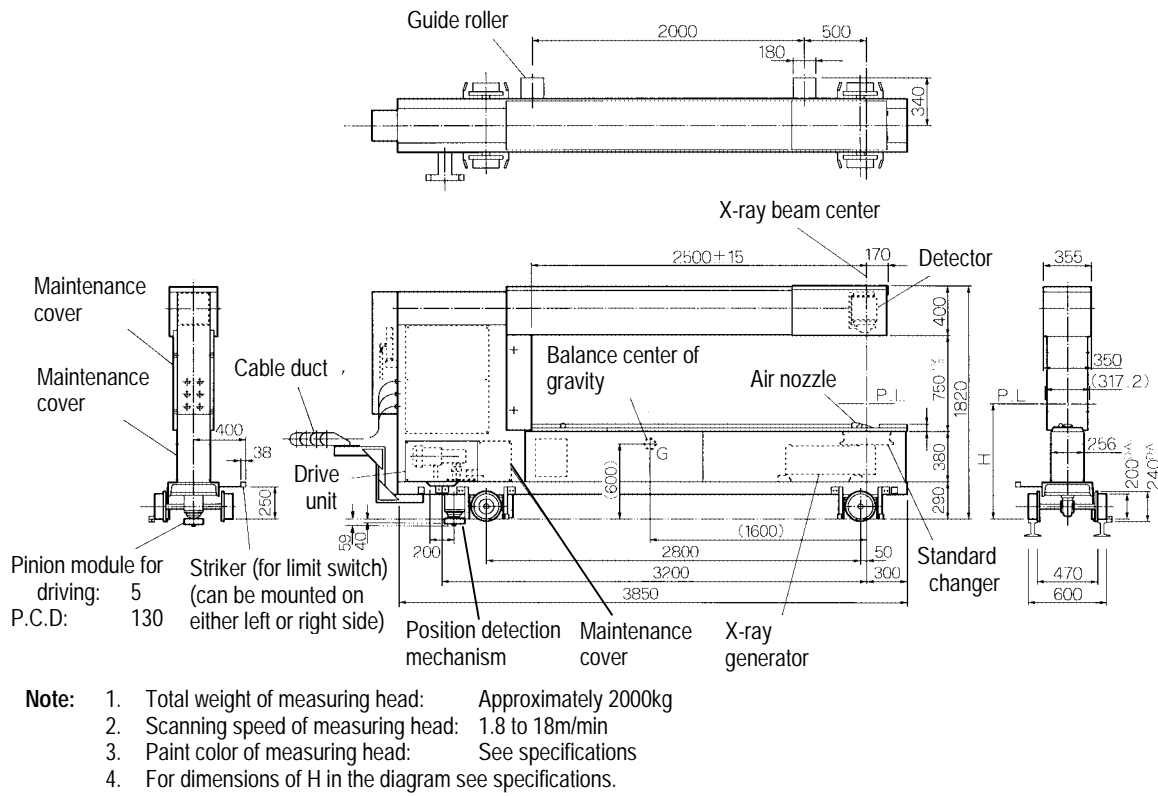

Figure 7 External Dimensions of Measuring Head (unit: mm)

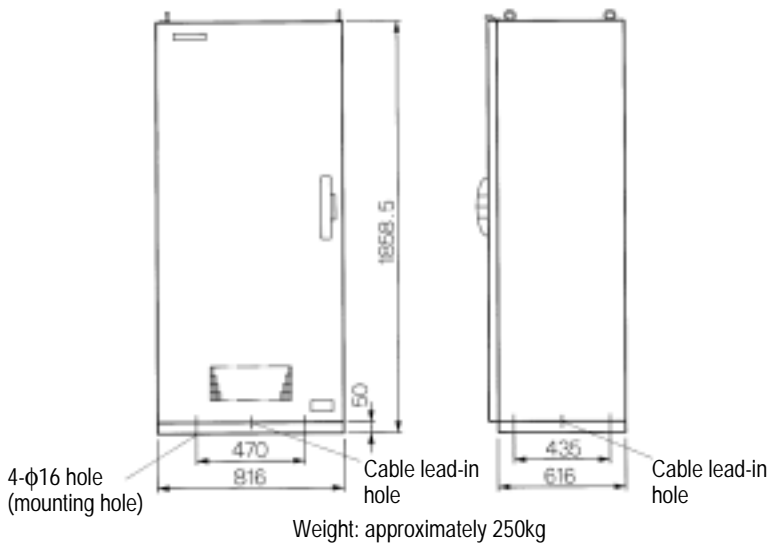

Figure 8 External Dimensions of Equipment Cabinet (unit: mm)

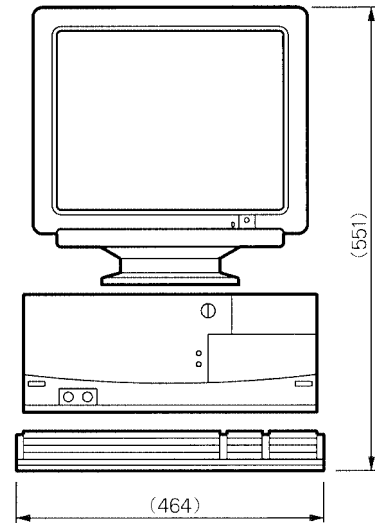

Figure 9 External Dimensions of Operation-PC (unit: mm)

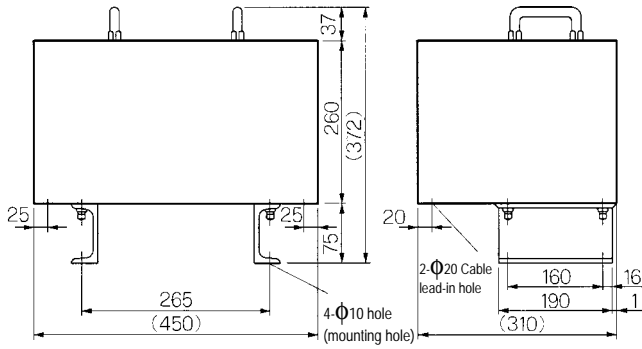
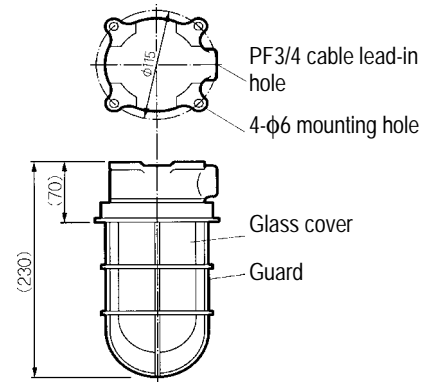

Figure 10 External Dimensions of Automatic Voltage Regulator (unit: mm)



Applicable lamp 110V AC, 40W

Figure 12 External Dimensions of Warning Lamp (unit: mm)

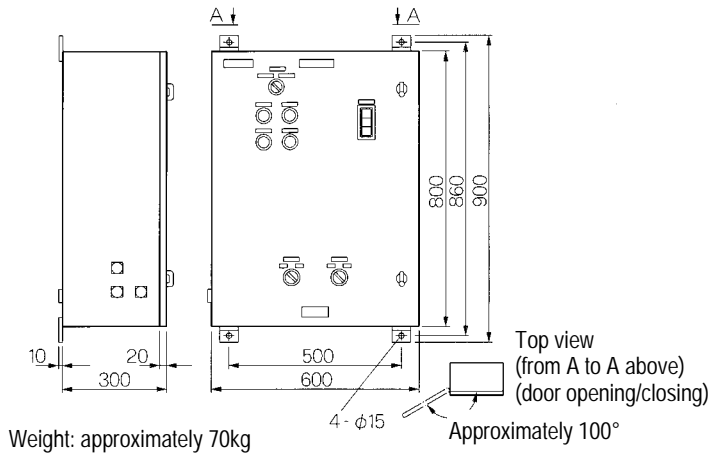

Figure 11 External Dimensions of Driving Control Box (unit: mm)

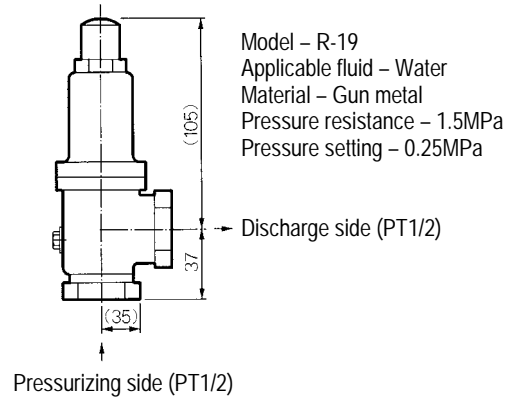
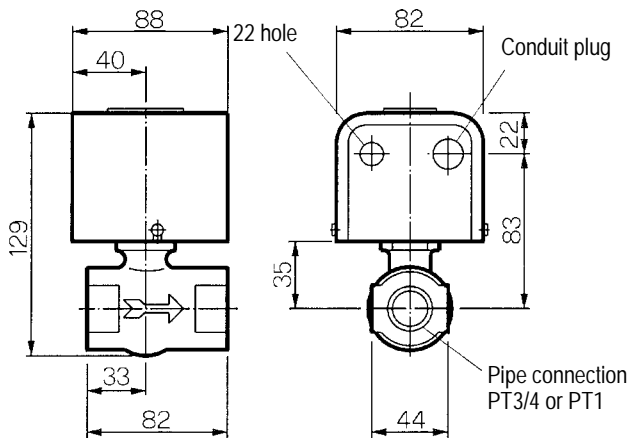

Figure 13 External Dimensions of Safety Valve (Unit: mm)



P. no.	Model no.	Connection port dia.	Switch
001	FS5-J-3/4	PT3/4	SPDT (1)
002	FS5-J-1	PT1	microswitch

Max. operating pressure: 1.03MPa
 Max. operating temperature: 120°C
 Material of parts contacting fluids: Chrome yellow, carbon, ethylene-propylene rubber
 Fluid: Water (acid, alkaline or oils cannot be used)
 Weight: 1.7kg
 Color: Black wrinkle finish

Figure 14 External Dimensions of Flow Switch (unit: mm)

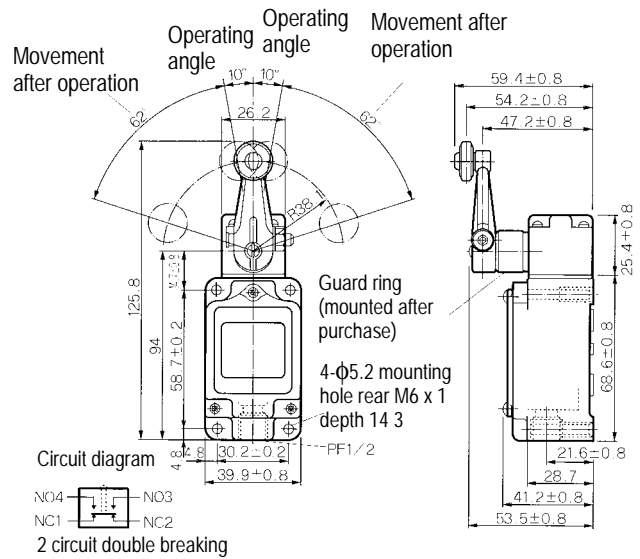
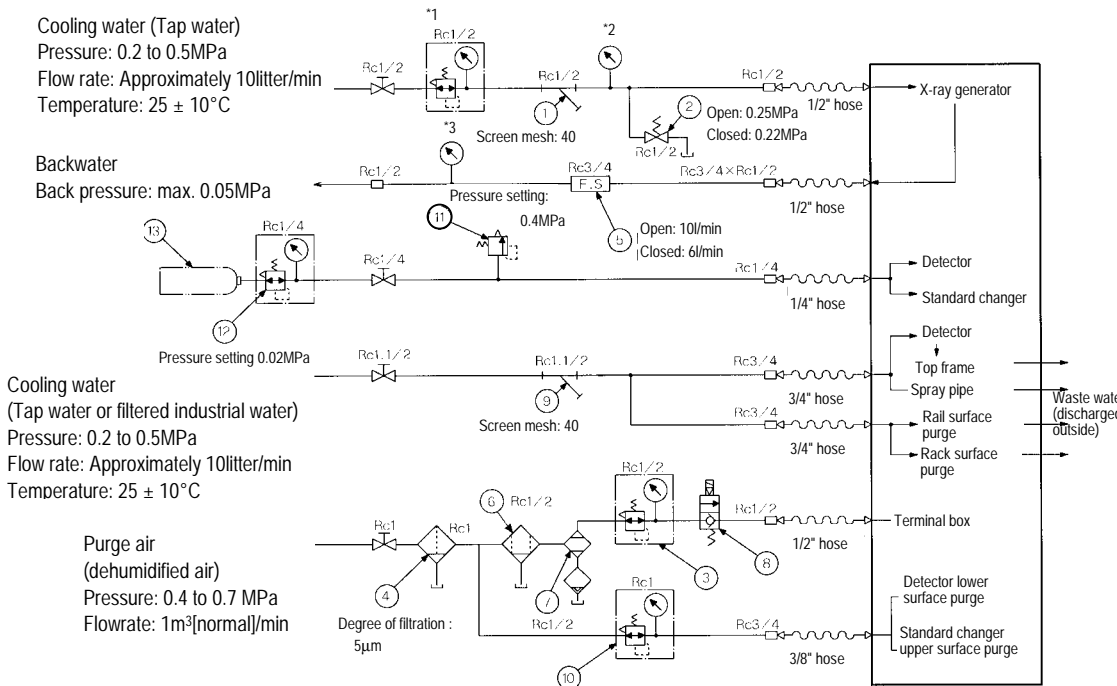

Figure 15 External Dimensions of Limit Switch (unit: mm)



NO.	Name	Remarks
1	Strainer	
2	Single entry safety valve	
3	Air reducing valve	
4	Air filter	
5	Flow switch	
6	Mist separator	
7	Air dryer	
8	Solenoid valve	
9	Strainer	
10	Air reducing valve	
11	Pressure escape valve	
12	Nitrogen reducing valve	
13	Nitrogen cylinder	Supplied by customer

Note: 1. in figure indicates JIS 0.98MPa ball valve.
 2. Scope of supply for piping parts depends on specifications.
 3. If there are large fluctuations in supply water pressure and pulsing, or if continuous operation of the safety valve causes problems with the amount of water discharge, a water pressure reducing valve* must be installed. In such cases, we recommend installing the pressure gages shown in * 2 and * 3.

Figure 16 Piping Connections

Other Related Models

In addition to the TOSGAGE-7525, the following models are also available for use on steel lines. For details, please contact a Toshiba sales representative.

TOSGAGE-7511 For general cold rolling

TOSGAGE-7521/7522 For general hot rolling

TOSGAGE-7524 For installation between hot rolling stands

Notes on using the system:

Because improper use of X-rays can be harmful to the human body, use of X-ray emitting technology is subject to the radiation-hazard safety regulations of your state.

Please abide by those regulations when using the TOSGAGE-7525.



Misuse of this product can result in property damage or human injury.
Read related manuals carefully before using this product.

Printed in Japan 2001-5 (TDOC)

© TOSHIBA Corporation 2001

All Rights Reserved.

- Windows NT is a registered trademark of Microsoft Corporation, in the United States and other countries.
- The information in this brochure is subject to change without notice.

TOSHIBA