

# SPECIFICATION FOR LCD MODULE

Model No. TM162ECAWG

<b>Prepared by:</b>	<b>Date:</b>
<b>Checked by :</b>	<b>Date:</b>
<b>Verified by :</b>	<b>Date:</b>
<b>Approved by:</b>	<b>Date:</b>

**TIANMA MICROELECTRONICS CO., LTD**

**REVISION RECORD**

<b>Date</b>	<b>Ref. Page</b>	<b>Revision No.</b>	<b>Revision Items</b>	<b>Check &amp; Approval</b>

## **1 General Specifications:**

1.1 Display type: **FSTN**

1.2 Display color\*:

Display color: **Blue-Black**

Background: **White**

1.3 Polarizer mode: **Reflective/Positive**

1.4 Viewing Angle: **6:00**

1.5 Driving Method: **1/16 Duty 1/5 Bias**

1.6 Without Backlight

- Color tone is slightly changed by temperature and driving voltage.

1.7 Display Fonts: **5 x 7 dots(1 Character)**

1.8 Data Transfer: **8 Bit Parallel**

1.9 Front Polarizer: **570C-K42-35D(-)**

Rear Polarizer: **SHC-125M**

1.10 Operating Temperature: **-20----+70°C**

Storage Temperature: **-30----+90°C**

1.11 Outline Dimensions: **Refer to outline drawing on next page**

1.12 Dot Matrix: **16 Characters X 2**

1.13 Dot Size: **0.55X0.65(mm)**

1.14 Dot Pitch: **0.6X0.7 (mm)**

1.15 Weight: **10g**

## 2 Outline Drawing

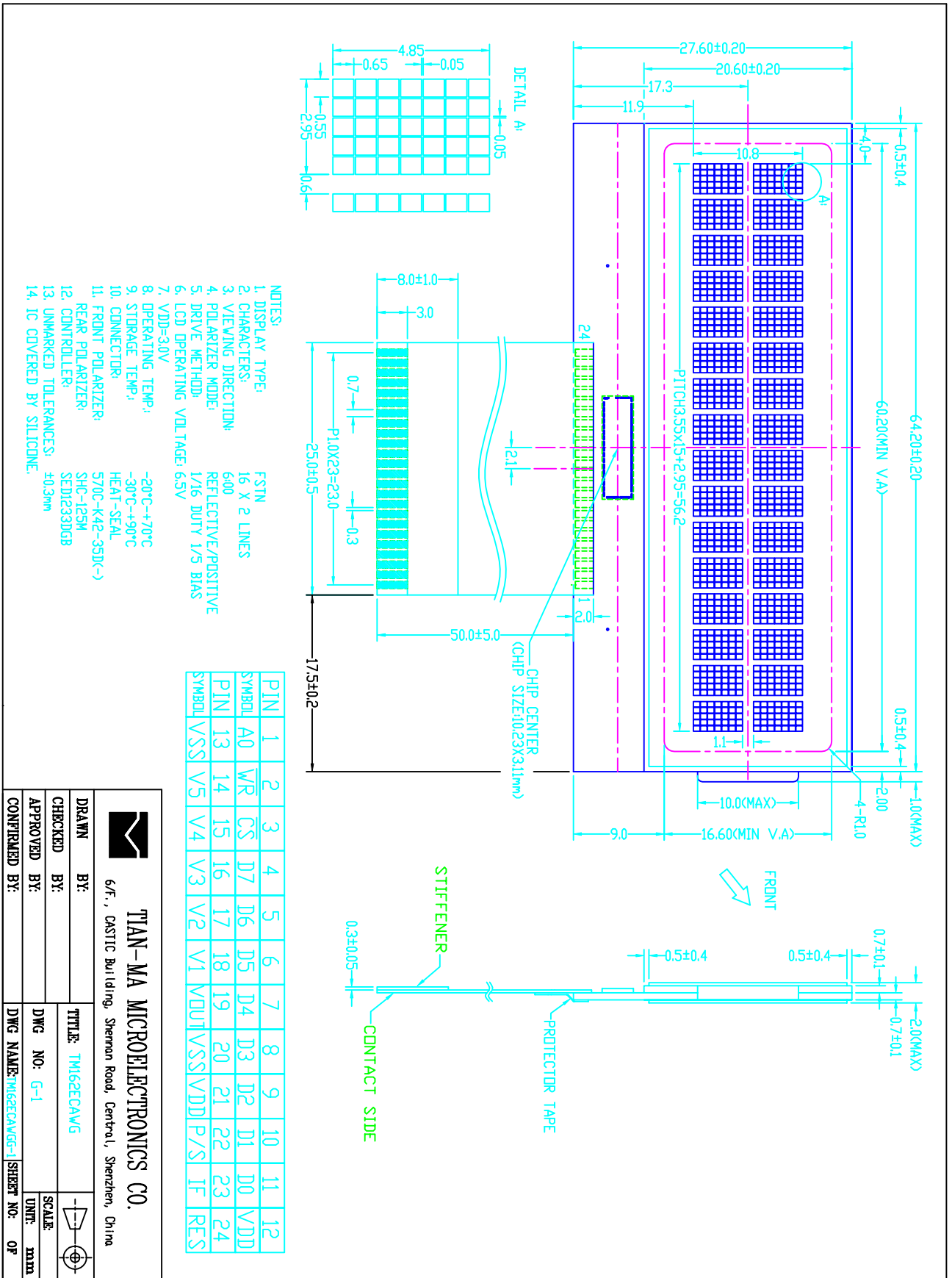

### 3 LCD Module Part Numbering System

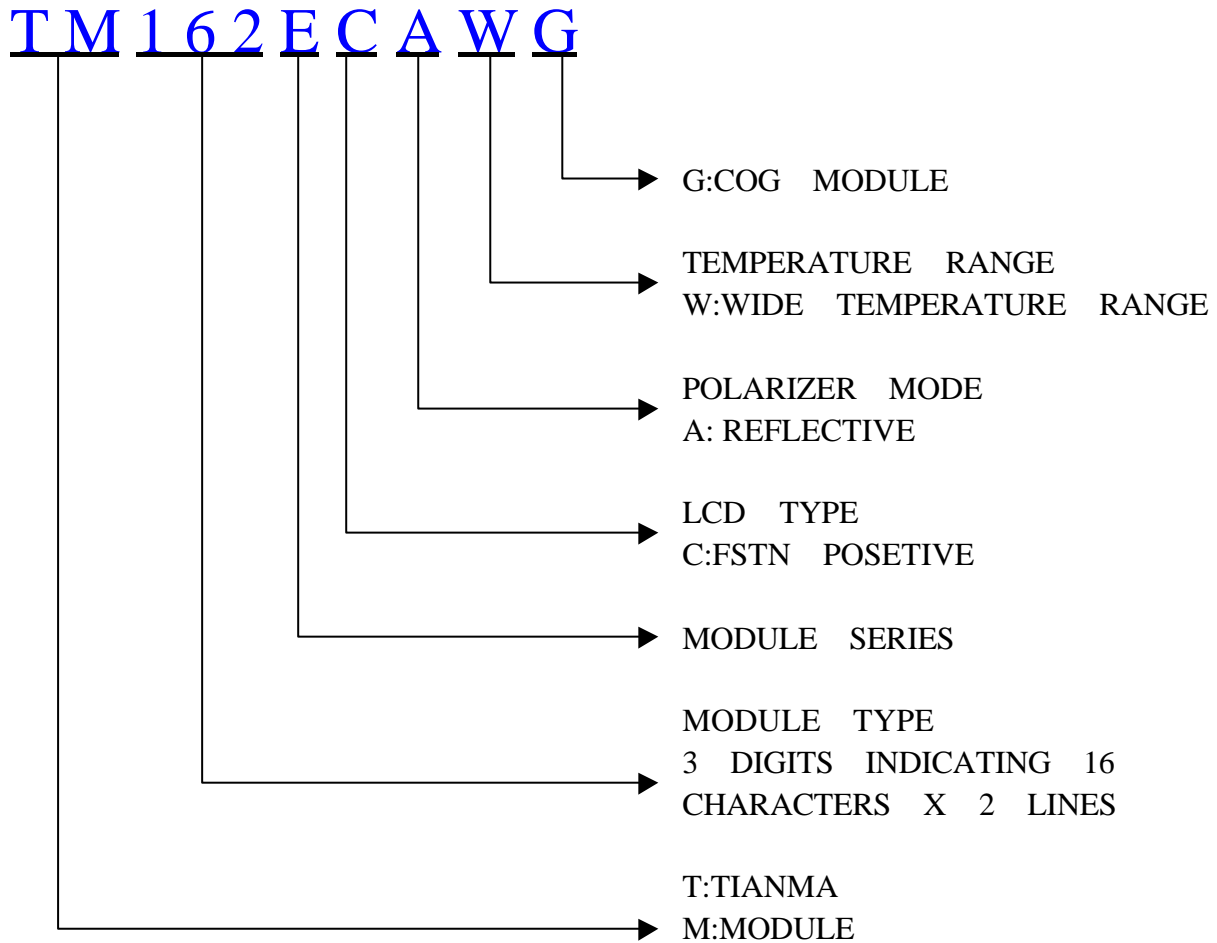

NOTE: LOTS NUMBERS ARE PRINTED ON THE LCD.

## 4 Circuit Block Diagram

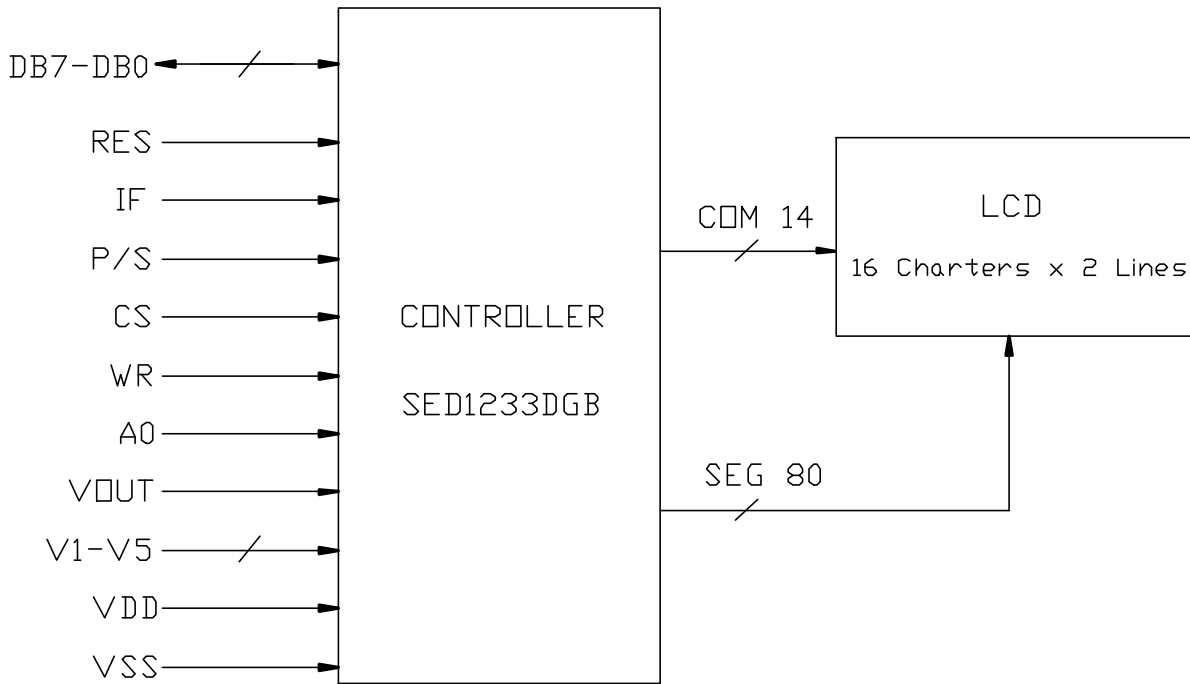

Block Diagram Example of Power Supply

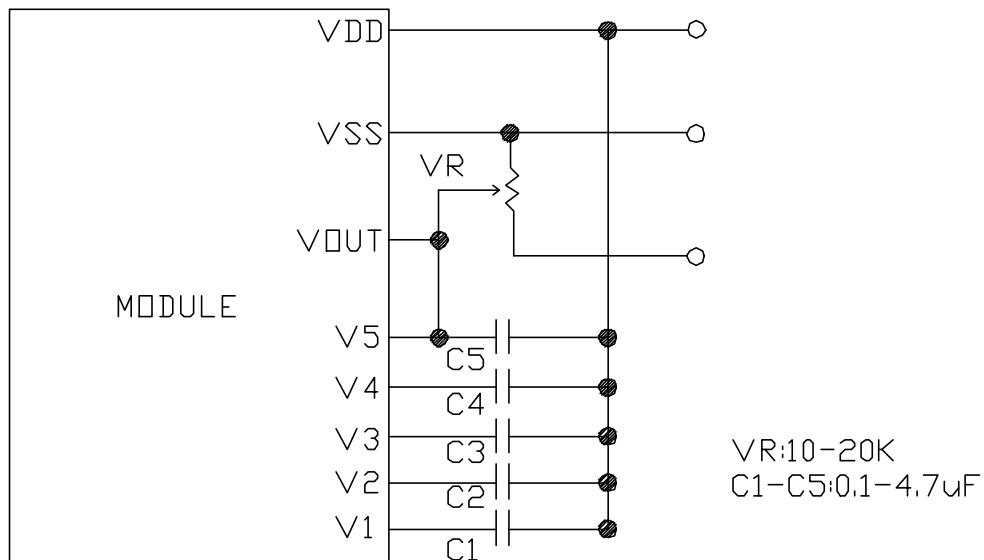

Both the boosting circuit and the voltage control circuit are not used in this module. Therefore, connect V5 pin with Vout pin and supply the LCD driving voltage from the outside.

## 5 Absolute Maximum Ratings

Item	Symbol	Min.	Max.	Unit	Remark
Power Supply Voltage	$V_{DD} - V_{SS}$	-0.3	6.0	V	
LCD Driving Voltage	$V_{LCD}$	-0.3	13.0		
Operating Temperature Range	$T_{OP}$	-20	+70	°C	No Condensation
Storage Temperature Range	$T_{ST}$	-30	+90		

## 6 Electrical Specifications and Instruction Code

### 6.1 Electrical characteristics

Item	Symbol	Min.	Typ.	Max.	Unit
Supply Voltage (Logic)	$V_{DD}-V_{SS}$	2.4	3.0	3.6	V
Supply Voltage (LCD Drive)	$V_{LCD}$	5.5	6.5	7.5	V
Input Signal Voltage	High $V_{IH}$ ( $V_{DD}=3.0$ )	$0.7V_{DD}$	-	$V_{DD}+0.3$	V
	Low $V_{IL}$ ( $V_{DD}=3.0$ )	-0.3	-	$0.2 V_{DD}$	V
Supply current (Logic)	$I_{DD}$ ( $V_{DD}-V_{SS}$ $=3.0$ )	-	50	100	uA



## 6.2 Interface Signals

Pin No.	Symbol	Level	Description
1	A0	H/L	H:D0-D7 are display data L:D0-D7 are controller command
2	$\overline{\text{WR}}$	H/L	80 family MPU:WR Signal Input L:Active 68 family MPU:Enable clock input
3	$\overline{\text{CS}}$	H/L	Chip selects signal L:Active
4	D7	H/L	Data Bus Line
5	D6	H/L	Data Bus Line
6	D5	H/L	Data Bus Line
7	D4	H/L	Data Bus Line
8	D3	H/L	Data Bus Line
9	D2	H/L	Data Bus Line
10	D1	H/L	Data Bus Line
11	D0	H/L	Data Bus Line
No--connection at 4-bit operation			
12	Vdd	3.0V	Supply Voltage
13	Vss	0V	Ground
14	V5	-	Connect to Vdd and a capacitor of 0.1 4.7 uF
15	V4	-	Connect to a capacitor of 0.1 4.7 uF
16	V3	-	Connect to a capacitor of 0.1 4.7 uF
17	V2	-	Connect to a capacitor of 0.1 4.7 uF
18	V1	-	Connect to a capacitor of 0.1 4.7 uF
19	Vout	-	Supply Voltage(LCD Drive)
20	Vss	-	Ground
21	Vdd	-	Supply Voltage (+3.0V)
22	P/S	H/L	H:Parallel Data Transfer L:Serial Data Transfer
23	IF	H/L	Interface Data Length Select H:8-bits Parallel L:4-bit Parallel
24	RES	H/L	Reset Signal

## 6.3 Interface Timing Chart

### TIMING CHARACTERISTICS

(1) System Bus Write Characteristic I (80 series MPU)

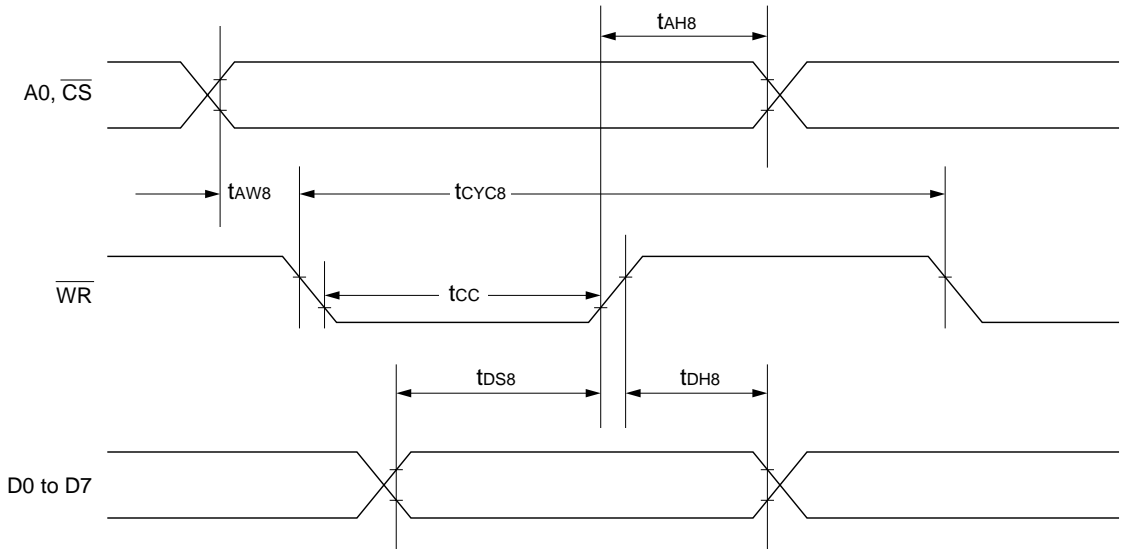

[ $V_{SS} = -3.6\text{ V to }-2.4\text{ V}$ ,  $T_a = -30\text{ to }85^\circ\text{C}$  unless otherwise specified]

Item	Signal	Symbol	Measuring condition	Min.	Max.	Unit
Address hold time	A0, $\overline{\text{CS}}$	$t_{\text{AH8}}$		30		ns
Address setup time	A0, $\overline{\text{CS}}$	$t_{\text{AW8}}$		60		ns
System cycle time	$\overline{\text{WR}}$	$t_{\text{CYC8}}$	$V_{SS} = -3.0$	500		ns
Control pulse width ( $\overline{\text{WR}}$ )		$t_{\text{CC}}$	$-2.7$	550		ns
			$-2.4$	650		
			$V_{SS} = -3.0$	100		
			$-2.7$	120		
			$-2.4$	150		
Data setup time	D0 ~ D7	$t_{\text{DS8}}$		100		ns
Data hold time	D0 ~ D7	$t_{\text{DH8}}$		50		ns

\*1: For the rise and fall of an input signal, set a value not exceeding 25 ns.

\*2: Every timing is specified on the basis of 20% and 80% of  $V_{SS}$ .

\*3: For A0 and  $\overline{\text{CS}}$ , the same time is not required. Input signals so that A0 and  $\overline{\text{CS}}$  may satisfy  $t_{\text{AW8}}$  and  $t_{\text{AH8}}$  respectively.

(2) System Bus Write Characteristic II (68 series MPU)

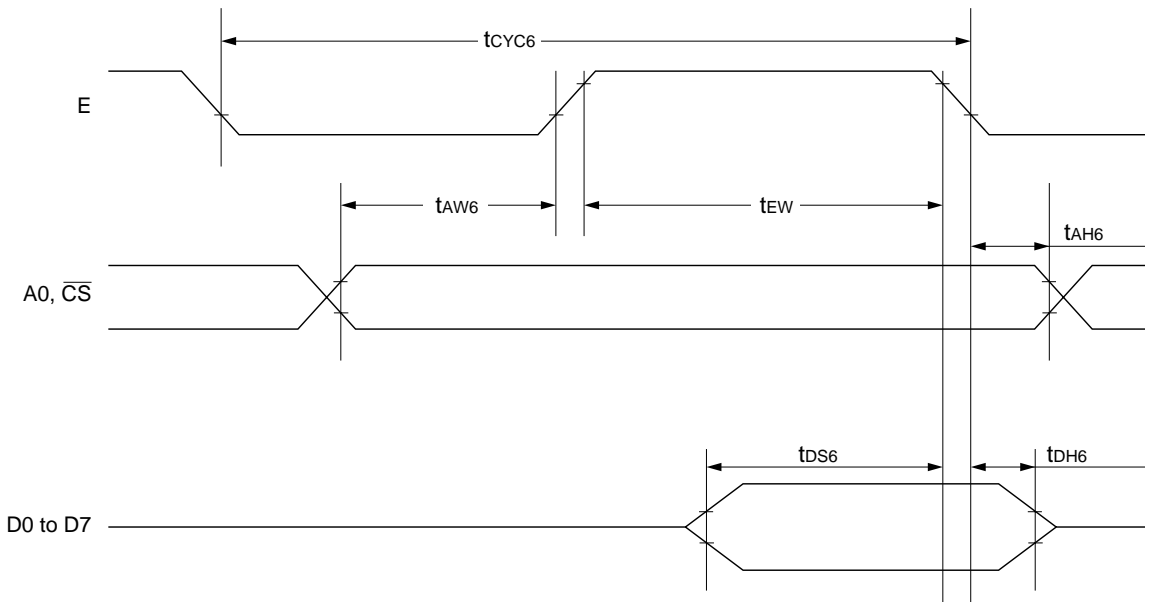

[V<sub>SS</sub> = -3.6 V to -2.4 V, T<sub>a</sub> = -30 to 85°C unless otherwise specified]

Item	Signal	Symbol	Measuring condition	Min.	Max.	Unit
System cycle time	A0, $\overline{CS}$	t <sub>CYC6</sub>	V <sub>SS</sub> = -3.0 -2.7 -2.4	500 550 650		ns
Address setup time		t <sub>AW6</sub>		60		
Address hold time		t <sub>AH6</sub>		30		ns
Data setup time	D0 ~ D7	t <sub>DS6</sub>		100		ns
Data hold time		t <sub>DH6</sub>		50		ns
Enable pulse width	E	t <sub>EW</sub>	V <sub>SS</sub> = -3.0 -2.7 -2.4	100 120 150		ns

- \*1: t<sub>CYC6</sub> denotes the cycle of the E signal in the  $\overline{CS}$  active state. t<sub>CYC6</sub> must be reserved after  $\overline{CS}$  becomes active.
- \*2: For the rise and fall of an input signal, set a value not exceeding 25 ns.
- \*3: Every timing is specified on the basis of 20% and 80% of V<sub>SS</sub>.
- \*4: For A0 and  $\overline{CS}$ , the same timing is not required. Input signals so that A0 and  $\overline{CS}$  may satisfy t<sub>AW6</sub> and t<sub>AH6</sub> respectively.

## 6.4 Instruction Code

Command	Code											Function	
	A0	WR	D7	D6	D5	D4	D3	D2	D1	D0			
(1) Cursor Home	0	0	0	0	0	1	*	*	*	*		Moves the cursor to the home position.	
(2) Static Display Control	0	0	0	0	1	0	*	*	SD1	SD0		Sets the display mode of static display symbol SD1, SD0 = 0, 0 (display OFF), 0, 1 (1 - 2 Hz blink), 1, 0 (3 4 Hz blink), 1, 1 (all display ON)	
(3) Display ON/OFF Control	0	0	0	0	1	1	C	B	DC	D		Sets cursor ON/OFF (C), cursor blink ON/OFF (B), double cursor ON/OFF (DC) and display ON/OFF (D). C = 1 (cursor ON) 0 (cursor OFF), B = 1 (blink ON) 0 (blink OFF) DC = 1 (double cursor ON) 0 (double cursor OFF), D = 1 (display ON) D = 0 (display OFF)	
(4) Power Save	0	0	0	1	0	0	*	*	0	PS		Sets power save ON/OFF (PS) and oscillating circuit ON/OFF (O). PS = 1 (power save ON) 0 (power save OFF), 0 = 1 (oscillating circuit ON) 0 (oscillating circuit OFF)	
(5) Power Control	0	0	0	1	0	1	0	VC	VF	P		Sets voltage regulating circuit ON/OFF and boosting circuit ON/OFF (P). VC = 1 (voltage regulating circuit ON) 0 (voltage regulating circuit OFF) VF = 1 (voltage follower ON) 0 (voltage follower OFF), P = 1 (boosting circuit ON) 0 (boosting circuit OFF)	
(6) System Set	0	0	0	1	1	0	N2	N1	*	CG		Sets the use or non-use of CG RAM and display lines (N2, N1). CG = 1 (use of CG RAM) 0 (non-use of CG RAM), N2, N1 = 0, 0 (2 lines) 0, 1 (3 lines) 1, 0 (4 lines)	
(7) Electronic Volume Register	0	0	0	1	1	1	MSB	LSB				Sets the electronic volume register value.	
(8) RAM Address Set	0	0	1	ADDRESS									Sets the DD RAM, CG RAM or symbol register address.
(9) RAM Write	1	0	DATA									Writes data into the DD RAM, CG RAM or symbol register address.	

## 7 Optical Characteristics

### 7.1 Optical Characteristics

Ta=25°C

Item	Symbol	Condition	Min.	Typ.	Max.	Unit	
Viewing Angle	$\theta_x$	Cr 2	$\theta_y=0^\circ$	-35	--	20	Deg
	$\theta_y$						
Contrast Ratio	Cr	$\theta_x=0^\circ$ $\theta_y=0^\circ$	4	-	-		
Response Time	Turn on	$\theta_x=0^\circ$ $\theta_y=0^\circ$	-	-	250	ms	
	Turn off						T <sub>off</sub>

## 7.2 Definition of Optical Characteristics

### 7.2.1 Definition of Viewing Angle

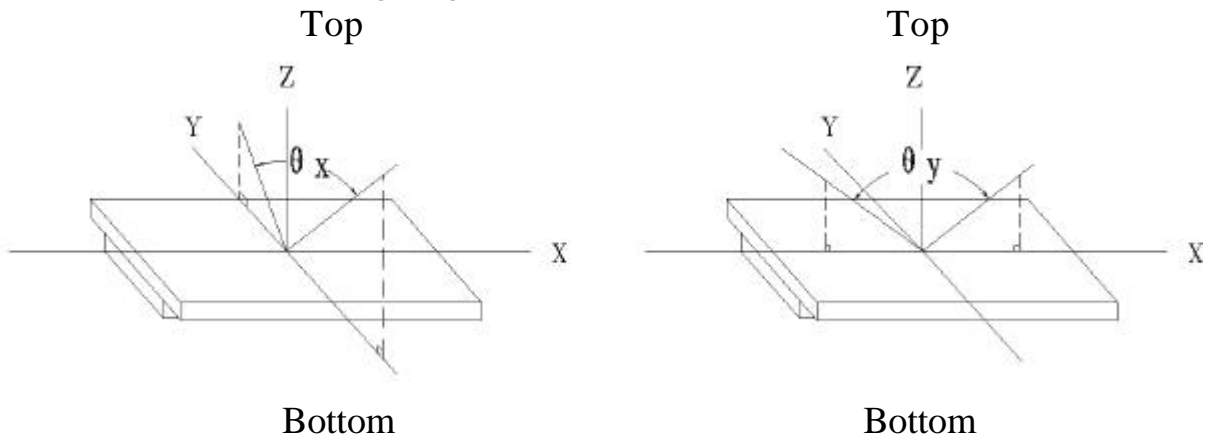

### 7.2.2 Definition of Contrast Ratio

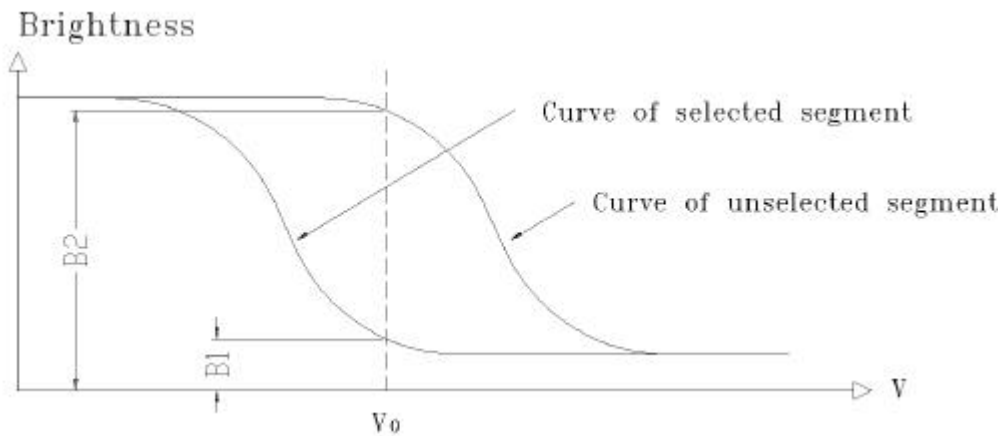

$$\text{Contrast Ratio} = B2/B1 = \frac{\text{unselected state brightness}}{\text{selected state brightness}}$$

Measuring Conditions:

- 1) Frame frequency: 100.0Hz

### 7.2.3 Definition of Response time

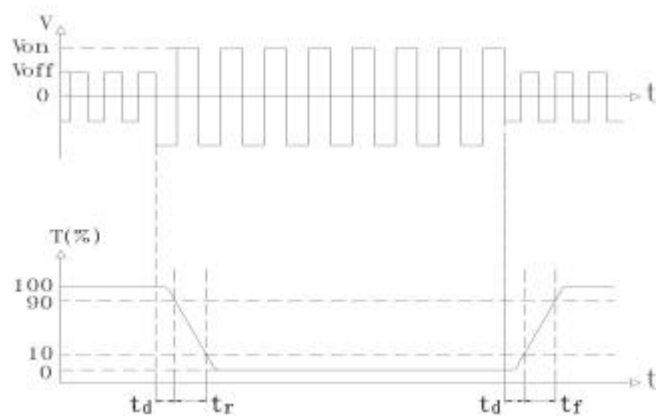

Turn on time:  $t_{on} = t_d + t_r$       Turn off time:  $t_{off} = t_d + t_f$

Measuring Condition:

- 1) Operating Voltage: 6.5V
- 2) Frame frequency: 100.0Hz

## 8 Reliability

### 8.1 Content of Reliability Test

Ta=25°C

No.	Test Item	Content of Test	Test condition
1	High Temperature Storage	Endurance test applying the high storage temperature for a long time	90°C 120H
2	Low Temperature Storage	Endurance test applying the low storage temperature for a long time	-30°C 240H
3	High Temperature Operation	Endurance test applying the electric stress (voltage & current) and the thermal stress to the element for a long time	70°C 240H
4	Low Temperature Operation	Endurance test applying the electric stress under low temperature for a long time	-20°C 240H
5	High Temperature /Humidity Storage	Endurance test applying the high temperature and high humidity storage for a long time	60°C 95%RH 240H 80°C 95%RH 48H (Non Condensate)
6	Temperature Cycle	Endurance test applying the low and high temperature cycle $-30^{\circ}\text{C} \xleftrightarrow{30\text{min}} 25^{\circ}\text{C} \xleftrightarrow{5\text{min}} 90^{\circ}\text{C} \xleftrightarrow{30\text{min}} 25^{\circ}\text{C} \xleftrightarrow{5\text{min}}$ <p style="text-align: center;">← 1 cycle →</p>	-30°C/90°C 10 cycles
7	Vibration Test (package state)	Endurance test applying the vibration during transportation	10Hz~500Hz, 100m/s <sup>2</sup> , 120min
8	Shock Test (package state)	Endurance test applying the shock during transportation	Half- sine wave, 300m/s <sup>2</sup> , 18ms
9	Atmospheric Pressure Test	Endurance test applying the atmospheric pressure during transportation by air	25kPa 16H

## 8.2 Failure Judgment Criterion

Criterion Item	Test Item No.									Failure Judgement Criterion
	1	2	3	4	5	6	7	8	9	
Basic Specification	0	0	0	0	0	0	0	0	0	Out of the basic Specification
Electrical specification	0	0	0	0	0					Out of the electrical specification
Mechanical Specification							0	0		Out of the mechanical specification
Optical Characteristic	0	0	0	0	0	0			0	Out of the optical specification
Note	For test item refer to 8.1									
Remark	Basic specification = Optical specification + Mechanical specification									



## 9 QUALITY LEVEL

Examination or Test	At $T_{amb}=25^{\circ}\text{C}$ (unless otherwise stated)	Inspection				
		Min.	Max.	Unit	IL	AQL
External Visual Inspection	Under normal illumination and eyesight condition, the distance between eyes and LCD is 25cm.	See annex A			II	Major 1.0 Minor 2.5
Display Defects	Under normal illumination and eyesight condition, display on inspection.	See annex B			II	Major 1.0 Minor 2.5
<p>Note: Major defects: Open segment or common, Short, Serious damages, Leakage            Miner defects: Others            Sampling standard conforms to GB2828</p>						

## **10 Precautions for Use of LCD Modules**

### 10.1 Handling Precautions

10.1.1 The display panel is made of glass. Do not subject it to a mechanical shock by dropping it from a high place, etc.

10.1.2 If the display panel is damaged and the liquid crystal substance inside it leaks out, be sure not to get any in your mouth, if the substance comes into contact with your skin or clothes, promptly wash it off using soap and water.

10.1.3 Do not apply excessive force to the display surface or the adjoining areas since this may cause the color tone to vary.

10.1.4 The polarizer covering the display surface of the LCD module is soft and easily scratched. Handle this polarizer carefully.

10.1.5 If the display surface is contaminated, breathe on the surface and gently wipe it with a soft dry cloth. If still not completely clear, moisten cloth with one of the following solvents:

- Isopropyl alcohol
- Ethyl alcohol

Solvents other than those mentioned above may damage the polarizer. Especially, do not use the following:

- Water
- Ketone
- Aromatic solvents

10.1.6 Do not attempt to disassemble the LCD Module.

10.1.7 If the logic circuit power is off, do not apply the input signals.

10.1.8 To prevent destruction of the elements by static electricity, be careful to maintain an optimum work environment.

- a. Be sure to ground the body when handling the LCD Modules.
- b. Tools required for assembly, such as soldering irons, must be properly ground.
- c. To reduce the amount of static electricity generated, do not conduct assembly and other work under dry conditions.
- d. The LCD Module is coated with a film to protect the display surface. Be care when peeling off this protective film since static electricity may be generated.

## 10.2 Storage precautions

10.2.1 When storing the LCD modules, avoid exposure to direct sunlight or to the light of fluorescent lamps.

10.2.2 The LCD modules should be stored under the storage temperature range. If the LCD modules will be stored for a long time, the recommend condition is:

Temperature :  $0^{\circ}\text{C} \sim 40^{\circ}\text{C}$

Relatively humidity:  $\leq 80\%$

10.2.3 The LCD modules should be stored in the room without acid, alkali and harmful gas.

10.3 The LCD modules should be no falling and violent shocking during transportation, and also should avoid excessive press, water, damp and sunshine.

# Annex A

## Inspection items and criteria for appearance defects

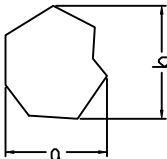
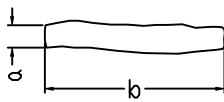
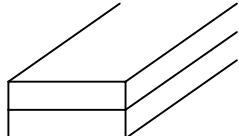
Items	Contents	Criteria			
Protective Glue		No clear defects			
Cover Tape		Covering all of the chip and no clear crimple			
Leakage		Not permitted			
Rainbow		According to the limit specimen			
Polarizer	Wrong polarizer attachment	Not permitted			
	Bubble between polarizer and glass	not counted	Max. 2 defect allowed		
		$\phi < 0.2\text{mm}$	$0.3\text{mm} < \phi < 0.5\text{mm}$		
	Scratches of polarizer	According to the limit specimen			
Black spot (in viewing area)		not counted	Max. 3 spots allowed	Max. 3 spots (lines) allowed	
		$X < 0.10\text{mm}$	$0.10\text{mm} < X < 0.25\text{mm}$		
		$X = (a+b)/2$			
Black line (in viewing area)		not counted	Max. 3 lines allowed		
		$a < 0.02\text{mm}$	$0.02\text{mm} < a < 0.05\text{mm}$ $b < 0.5\text{mm}$		
Progressive cracks		Not permitted			

# Annex A

## Inspection items and criteria for appearance defects (continued)

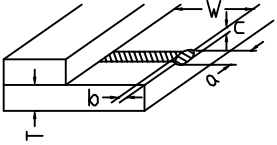
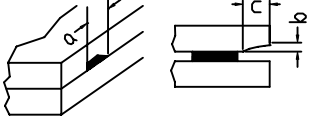
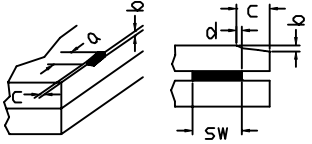
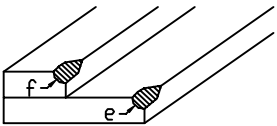
Items	Contents	Criteria						
Glass Cracks	cracks on pads 	a	b	c	Max. 2 cracks allowed	Max. 5 cracks allowed		
	$<3\text{mm}$	$\leq W/5$	$\leq T/2$	$<3\text{mm}$			$\leq W/5$	$>T/2$
	cracks on contact side 	a		b			Max. 2 cracks allowed	
	$\leq 3\text{mm}$		$\leq T/2$					
	$\leq 2\text{mm}$		$T/2 < b < T$					
	c shall be not reach the seal area							
	cracks on non-contact side 	a		b			Max. 2 cracks allowed	
	$\leq 3\text{mm}$		$\leq T/2$					
	$\leq 2\text{mm}$		$T/2 < b < T$					
c $\leq 0.5\text{mm}$								
d $\leq sw/3$								
Corner cracks 	$e < 2.0\text{mm}^2$ $f < 2.0\text{mm}^2$				Max. 3 cracks allowed			

# Annex B

## Inspection items and criteria for display defects

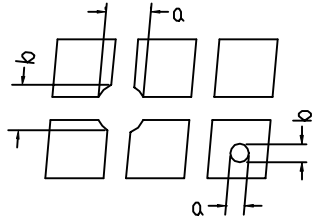
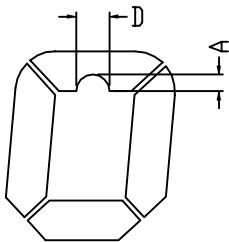
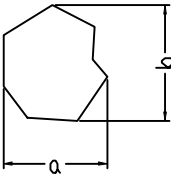
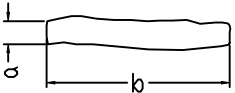
Items	Contents	Criteria		
Open segment or open common		Not permitted		
short		Not permitted		
Wrong viewing angle		Not permitted		
Contrast ratio uneven		According to the limit specimen		
Crosstalk		According to the limit specimen		
Pin holes and cracks in segment (DOT)		Not counted	Max. 3 dots allowed	Max. 3 dots allowed
		Not counted	Max. 2 dots allowed	
Black spot (in viewing area)		Not counted	Max. 3 spots allowed	Max. 3 spots (lines) allowed
		$X < 0.1\text{mm}$	$0.1\text{mm} \leq X \leq 0.2\text{mm}$	
Black line (in viewing area)		Not counted	Max. 3 lines allowed	
		$a < 0.02\text{mm}$	$0.02\text{mm} \leq a \leq 0.05\text{mm}$ $b \leq 0.5\text{mm}$	

# Annex B

## Inspection items and criteria for display defects (continued)

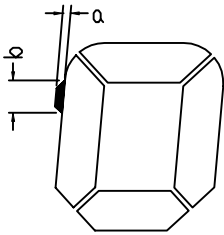
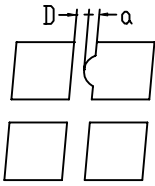
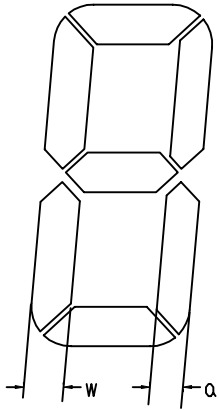
Items	Contents	Criteria				
Transformation of segment		Not counted	Max. 2 defects allowed	Max. 3 defects allowed		
		$X < 0.1\text{mm}$	$0.1\text{mm} \leq X \leq 0.20\text{mm}$			
		$X = (a+b)/2$				
		Not counted	Max. 1 defects allowed			
		$a < 0.1\text{mm}$	$0.1\text{mm} \leq a \leq 0.20\text{mm}$ $D > 0$			
		<p>Max. 2 defects allowed  <math>0.8W \leq a \leq 1.2W</math></p> <p><math>a</math>=measured value of width  <math>W</math>=nominal value of width</p>				