

DATA SHEET

TDA1015T 0,5 W audio power amplifier

Product specification
File under Integrated Circuits, ICO1

March 1986

0,5 W audio power amplifier**TDA1015T****GENERAL DESCRIPTION**

The TDA1015T is a low-cost audio amplifier which can deliver up to 0,5 W output power into a 16 Ω load impedance at a supply voltage of 9 V. The amplifier is specially designed for portable applications such as radios and recorders. The IC has a very low supply voltage requirement (3,6 V min.).

Features

- High input impedance
- Separated preamplifier and power amplifier
- Limited noise behaviour at radio frequencies
- Short-circuit protected
- Miniature encapsulation.

QUICK REFERENCE DATA

Supply voltage range	V_P	3,6 to 12 V
Peak output current	I_{OM}	max. 1 A
Output power	P_o	typ. 0,5 W
Voltage gain power amplifier	G_{V1}	typ. 29 dB
Voltage gain preamplifier	G_{V2}	typ. 23 dB
Total quiescent current	I_{tot}	max. 22 mA
Operating ambient temperature range	T_{amb}	-25 to +150 °C
Storage temperature range	T_{stg}	-55 to + 150 °C

PACKAGE OUTLINE

8-lead mini-pack; plastic (SO8; SOT96A); SOT96-1; 1996 July 23.

0,5 W audio power amplifier

TDA1015T

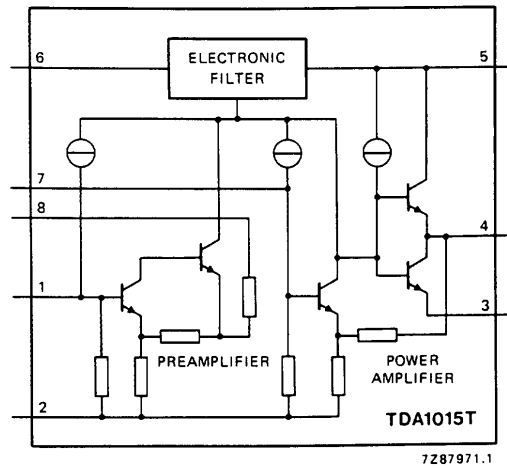

Fig.1 Block diagram.

RATINGS

Limiting values in accordance with the Absolute Maximum System (IEC 134)

Supply voltage	V_P	max.	12 V
Peak output current	I_{OM}	max.	1 A
Total power dissipation	see derating curve Fig.2		
Storage temperature range	-55 to + 150 °C		
A.C. short-circuit duration of load during sine-wave drive at $V_P = 9 V$	t_{sc}	max.	1 hour

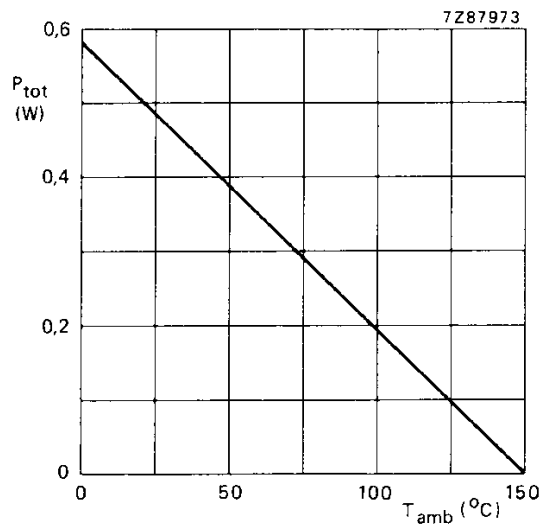

Fig.2 Power derating curve.

0,5 W audio power amplifier

TDA1015T

CHARACTERISTICS

$T_{amb} = 25\text{ °C}$; $V_P = 9\text{ V}$; $R_L = 16\ \Omega$; $f = 1\text{ kHz}$; see Fig.3; unless otherwise specified

SYMBOL	PARAMETER	MIN.	TYP.	MAX.	UNIT
V_P	Supply voltage	3,6	9	12	V
I_{ORM}	Repetitive peak output current	–	–	1	A
I_{tot}	Total quiescent current	–	12	22	mA
	A.F. output power at $d_{tot} = 10\%$; note 1				
P_o	$V_P = 9\text{ V}$; $R_L = 16\ \Omega$	–	0,5	–	W
P_o	$V_P = 6\text{ V}$; $R_L = 8\ \Omega$	–	0,3	–	W
G_{V1}	Voltage gain power amplifier	–	29	–	dB
G_{V2}	Voltage gain preamplifier (note 2)	–	23	–	dB
G_{tot}	Total voltage gain	49	52	55	dB
B	Frequency response at -3 dB (note 3)	–	60 to 15 000	–	Hz
$ Z_{i1} $	Input impedance power amplifier	–	20	–	k Ω
$ Z_{i2} $	Input impedance preamplifier (note 4)	100	200	–	k Ω
$ Z_{o2} $	Output impedance preamplifier	0,5	1	1,5	k Ω
	Output voltage preamplifier (r.m.s. value)				
$V_{o2(rms)}$	$d_{tot} < 1\%$ (note 2)	–	0,7	–	V
	Noise output voltage (r.m.s. value); note 5				
$V_{n(rms)}$	$R_S = 0\ \Omega$	–	0,2	–	mV
$V_{n(rms)}$	$R_S = 10\text{ k}\Omega$	–	0,5	–	mV
	Noise output voltage (r.m.s. value)				
$V_{n(rms)}$	$f = 500\text{ kHz}$; $B = 5\text{ kHz}$; $R_S = 0\ \Omega$	–	8	–	μV
	Ripple rejection at $f = 100\text{ Hz}$;				
RR	$C2 = 1\ \mu\text{F}$ (note 6)	–	38	–	dB

Notes to the characteristics

1. Output power is measured with an ideal coupling capacitor to the speaker load.
2. Measured with a load resistance of 20 k Ω .
3. The frequency response is mainly determined by the capacitors, C1, C3 (low frequency) and C4 (high frequency).
4. Independent of load impedance of preamplifier.
5. Effective unweighted r.m.s. noise voltage measured in a bandwidth from 60 Hz to 15 kHz (slopes 12 dB/octave).
6. Ripple rejection measured with a source impedance between 0 and 2 k Ω (maximum ripple amplitude of 2 V).

0,5 W audio power amplifier

TDA1015T

APPLICATION INFORMATION

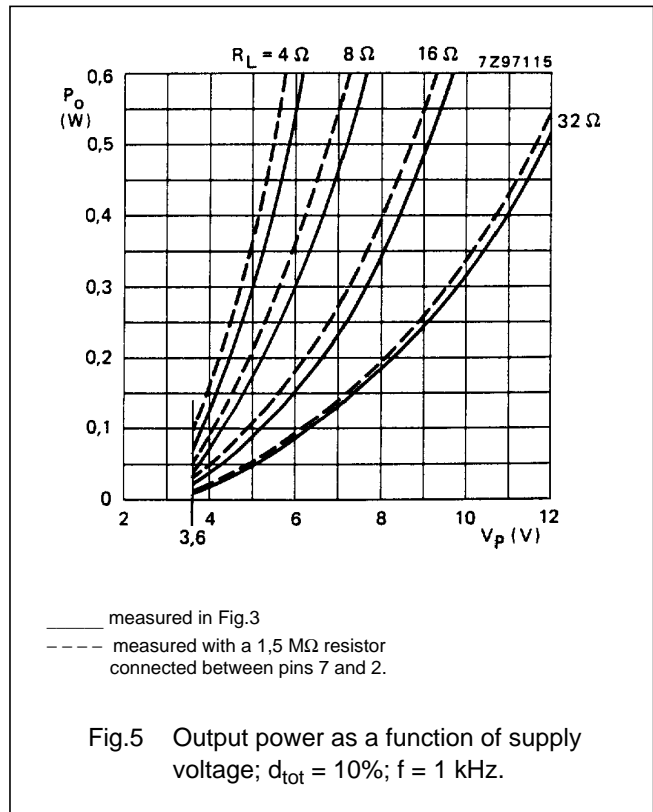
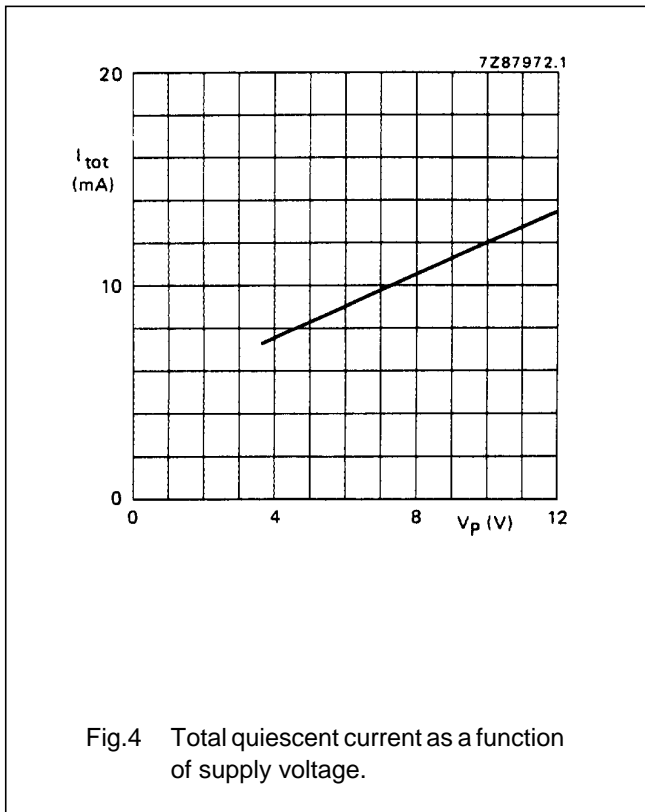
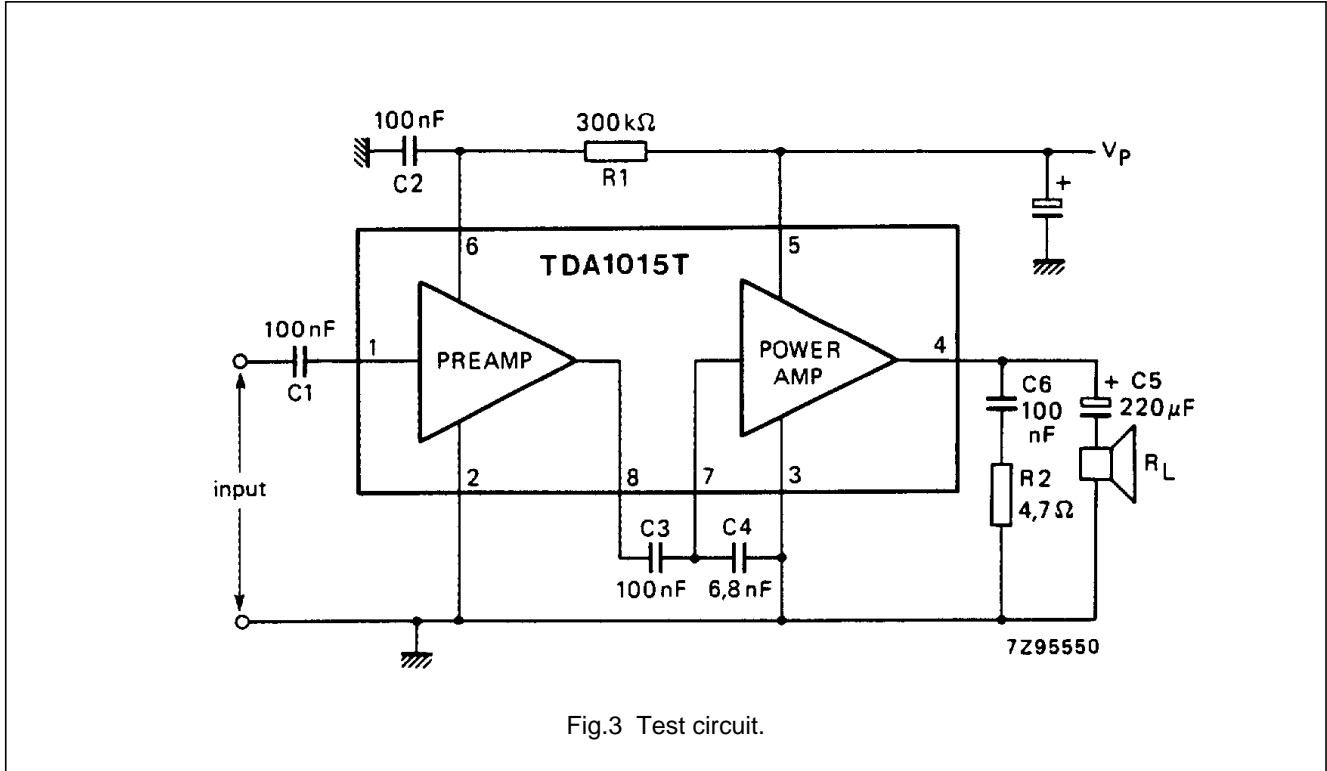

0,5 W audio power amplifier

TDA1015T

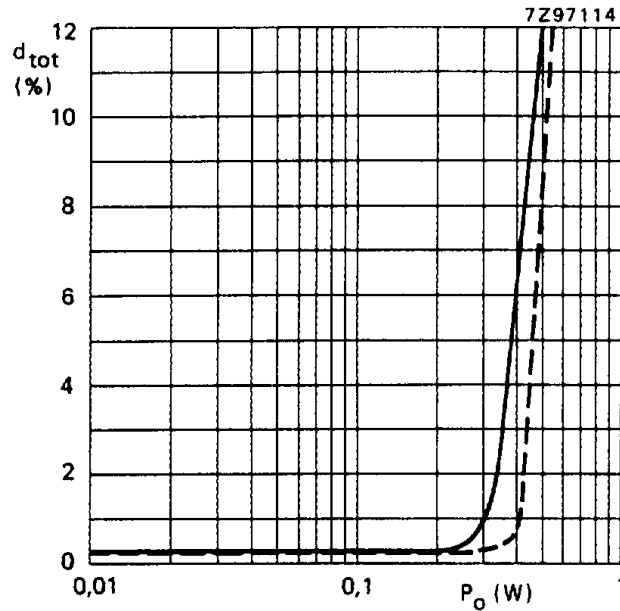

— measured in Fig.3
 - - - measured with a 1,5 MΩ resistor connected between pins 7 and 2.

Fig.6 Total distortion as a function of output power; $V_P = 9\text{ V}$; $R_L = 16\ \Omega$; $f = \text{kHz}$.

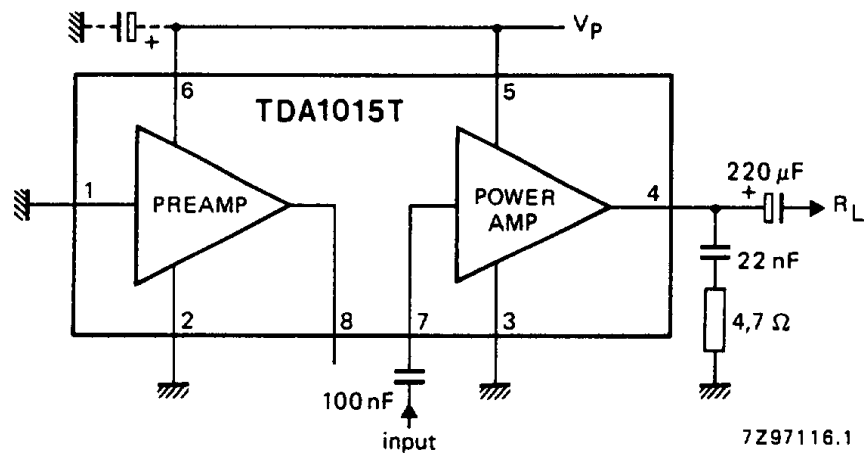

Fig.7 Application circuit for power stage only and battery power supply; $G_{V1} = 29\text{ dB}$; $|Z_{i1}| = 20\text{ k}\Omega$.

0,5 W audio power amplifier

TDA1015T

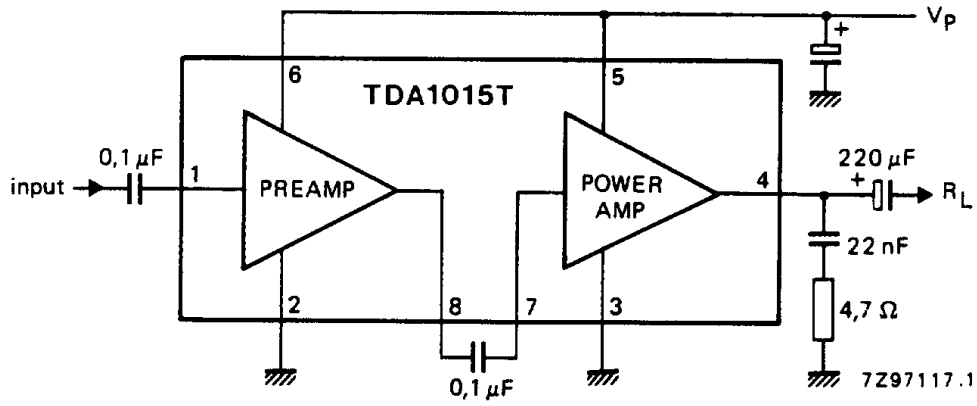

Fig.8 Application circuit for preamplifier and power amplifier stages and battery power supply;
 $G_{v\ tot} = 52\ dB$; $|Z_{i2}| = 200\ k\Omega$.

0,5 W audio power amplifier

TDA1015T

PACKAGE OUTLINE

S08: plastic small outline package; 8 leads; body width 3.9 mm

SOT96-1

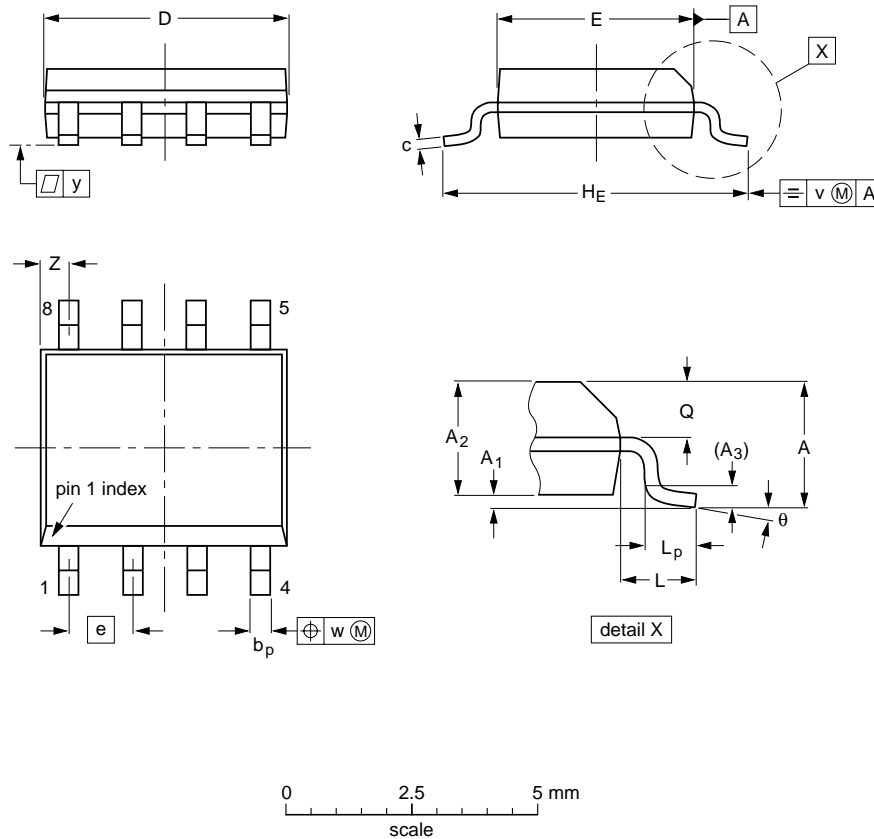

DIMENSIONS (inch dimensions are derived from the original mm dimensions)

UNIT	A max.	A ₁	A ₂	A ₃	b _p	c	D ⁽¹⁾	E ⁽²⁾	e	H _E	L	L _p	Q	v	w	y	z ⁽¹⁾	θ
mm	1.75	0.25 0.10	1.45 1.25	0.25	0.49 0.36	0.25 0.19	5.0 4.8	4.0 3.8	1.27	6.2 5.8	1.05	1.0 0.4	0.7 0.6	0.25	0.25	0.1	0.7 0.3	8° 0°
inches	0.069	0.010 0.004	0.057 0.049	0.01	0.019 0.014	0.0100 0.0075	0.20 0.19	0.16 0.15	0.050	0.244 0.228	0.041	0.039 0.016	0.028 0.024	0.01	0.01	0.004	0.028 0.012	

Notes

1. Plastic or metal protrusions of 0.15 mm maximum per side are not included.
2. Plastic or metal protrusions of 0.25 mm maximum per side are not included.

OUTLINE VERSION	REFERENCES				EUROPEAN PROJECTION	ISSUE DATE
	IEC	JEDEC	EIAJ			
SOT96-1	076E03S	MS-012AA				95-02-04 97-05-22

0,5 W audio power amplifier

TDA1015T

SOLDERING

Introduction

There is no soldering method that is ideal for all IC packages. Wave soldering is often preferred when through-hole and surface mounted components are mixed on one printed-circuit board. However, wave soldering is not always suitable for surface mounted ICs, or for printed-circuits with high population densities. In these situations reflow soldering is often used.

This text gives a very brief insight to a complex technology. A more in-depth account of soldering ICs can be found in our "*IC Package Databook*" (order code 9398 652 90011).

Reflow soldering

Reflow soldering techniques are suitable for all SO packages.

Reflow soldering requires solder paste (a suspension of fine solder particles, flux and binding agent) to be applied to the printed-circuit board by screen printing, stencilling or pressure-syringe dispensing before package placement.

Several techniques exist for reflowing; for example, thermal conduction by heated belt. Dwell times vary between 50 and 300 seconds depending on heating method. Typical reflow temperatures range from 215 to 250 °C.

Preheating is necessary to dry the paste and evaporate the binding agent. Preheating duration: 45 minutes at 45 °C.

Wave soldering

Wave soldering techniques can be used for all SO packages if the following conditions are observed:

- A double-wave (a turbulent wave with high upward pressure followed by a smooth laminar wave) soldering technique should be used.
- The longitudinal axis of the package footprint must be parallel to the solder flow.
- The package footprint must incorporate solder thieves at the downstream end.

During placement and before soldering, the package must be fixed with a droplet of adhesive. The adhesive can be applied by screen printing, pin transfer or syringe dispensing. The package can be soldered after the adhesive is cured.

Maximum permissible solder temperature is 260 °C, and maximum duration of package immersion in solder is 10 seconds, if cooled to less than 150 °C within 6 seconds. Typical dwell time is 4 seconds at 250 °C.

A mildly-activated flux will eliminate the need for removal of corrosive residues in most applications.

Repairing soldered joints

Fix the component by first soldering two diagonally-opposite end leads. Use only a low voltage soldering iron (less than 24 V) applied to the flat part of the lead. Contact time must be limited to 10 seconds at up to 300 °C. When using a dedicated tool, all other leads can be soldered in one operation within 2 to 5 seconds between 270 and 320 °C.

0,5 W audio power amplifier**TDA1015T**

DEFINITIONS

Data sheet status	
Objective specification	This data sheet contains target or goal specifications for product development.
Preliminary specification	This data sheet contains preliminary data; supplementary data may be published later.
Product specification	This data sheet contains final product specifications.
Limiting values	
Limiting values given are in accordance with the Absolute Maximum Rating System (IEC 134). Stress above one or more of the limiting values may cause permanent damage to the device. These are stress ratings only and operation of the device at these or at any other conditions above those given in the Characteristics sections of the specification is not implied. Exposure to limiting values for extended periods may affect device reliability.	
Application information	
Where application information is given, it is advisory and does not form part of the specification.	

LIFE SUPPORT APPLICATIONS

These products are not designed for use in life support appliances, devices, or systems where malfunction of these products can reasonably be expected to result in personal injury. Philips customers using or selling these products for use in such applications do so at their own risk and agree to fully indemnify Philips for any damages resulting from such improper use or sale.