

---

## High Sensitivity Speed Sensor IC with Dual Quadrature Outputs

---

### FEATURES

- Two independent digital quadrature A/B outputs
- Large air gap
- South and North pole pre-induction possible
- Low start-up voltage: 3.8V (Typ.)
- Reduced power consumption: 6.5mA (Typ.)
- Accurate true zero-crossing switch-point
- -40°C-150°C operating temperature range
- Over-voltage protection in all PIN
- Reverse-current protection in V<sub>DD</sub> PIN
- Output protection against electrical disturbances

### DESCRIPTION

SC9632 is a differential Hall Effect sensor IC with two independent channels providing quadrature outputs. The device provides a high sensitivity and a superior stability over temperature and symmetrical thresholds in order to achieve a stable duty cycle. The integrated circuit is response to changing differential magnetic fields created by rotating ring magnets and by ferrous targets when coupled with a magnet. By use of the A/B quadrature outputs, the device is particularly suitable for speed and direction of magnetic ring or ferromagnetic toothed wheels.

The device is packaged in a 4-pin plastic SIP. It is lead (Pb) free, with 100% matte tin plated lead frame.



## CONTENTS

<b>FEATURES</b> .....	- 1 -	<i>Magnetic Characteristics</i> .....	- 7 -
<b>DESCRIPTION</b> .....	- 1 -	<b>TYPICAL CHARACTERISTICS</b> .....	- 8 -
<b>BLOCK DIAGRAM</b> .....	- 3 -	<b>FUNCTIONAL DESCRIPTION</b> .....	- 9 -
<b>ORDERING INFORMATION</b> .....	- 3 -	<i>Power Derating Description</i> .....	- 10 -
<b>TERMINAL CONFIGURATION</b> .....	- 4 -	<i>Gear Tooth Sensing</i> .....	- 11 -
<b>ABSOLUTE MAXIMUM RATINGS</b> .....	- 5 -	<b>TYPICAL APPLICATION</b> .....	- 12 -
<b>ESD PROTECTION</b> .....	- 5 -	<b>PACKAGE INFORMATION</b> .....	- 13 -
<b>Thermal Characteristics</b> .....	- 5 -	<b>REVISION HISTORY</b> .....	- 14 -
<b>OPERATING CHARACTERISTICS</b> .....	- 6 -		
<i>Electrical parameters</i> .....	- 6 -		

## BLOCK DIAGRAM

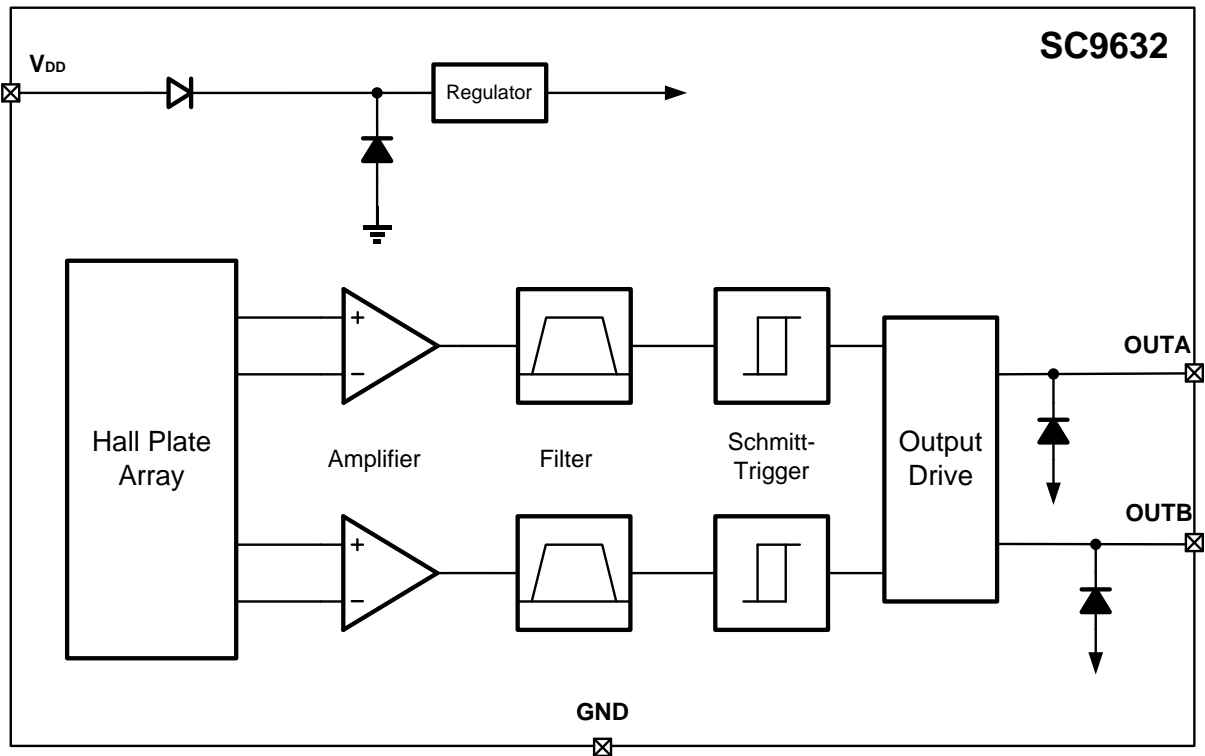

## ORDERING INFORMATION

Part Number	Packing	Mounting	Ambient, T <sub>A</sub>	Marking
SC9632VB	Bulk, 500 pieces/bag	4-pin SIP	-40°C to 150°C	9632

## TERMINAL CONFIGURATION

4-Terminal SIP  
VB Package  
(Top View)

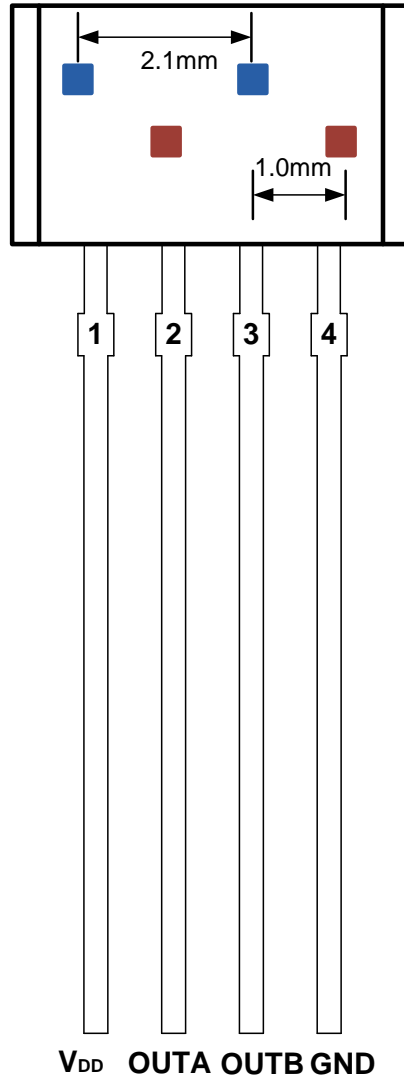

Terminal		Type	Description
Name	Number		
V <sub>DD</sub>	1	PWR	3.8V ~ 24 V power supply
OUTA	2	Output	Open-drain output required a pull-up resistor
OUTB	3	Output	Open-drain output required a pull-up resistor
GND	4	Ground	Ground

## ABSOLUTE MAXIMUM RATINGS

Parameter	Symbol	Limit Values		Units
		Min.	Max.	
Power supply voltage	$V_{DD}$	-30	30	V
Output terminal voltage	$V_{OUT}$	-0.5	30	V
Output terminal current sink	$I_{SINK}$	0	40	mA
Operating junction temperature	$T_J$	-40	165	°C
Storage temperature	$T_{STG}$	-65	175	°C

Note: Stresses above those listed here may cause permanent damage to the device. Exposure to absolute maximum rating conditions for extended periods may affect device reliability.

## ESD PROTECTION

Human Body Model (HBM) tests according to: standard AEC-Q100-002、AEC-Q100-003

Parameter	Symbol	Limit Values		Units
		Min.	Max.	
HBM mode ESD stress	$V_{ESD}$	-4.0	4.0	kV
MM mode ESD stress	$V_{ESD}$	-300	300	V

## Thermal Characteristics

Symbol	Parameter	Test Conditions	Rating	Units
$R_{\theta JA}$	Package thermal resistance	Single-layer PCB, with copper limited to solder pads	177	°C/W

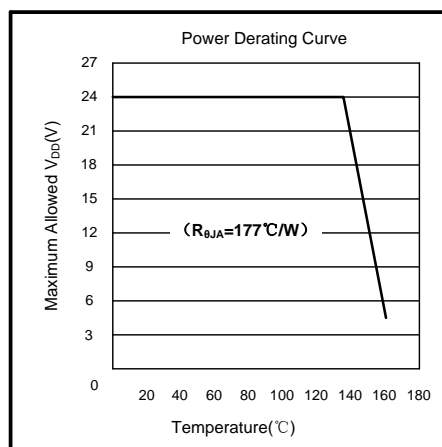
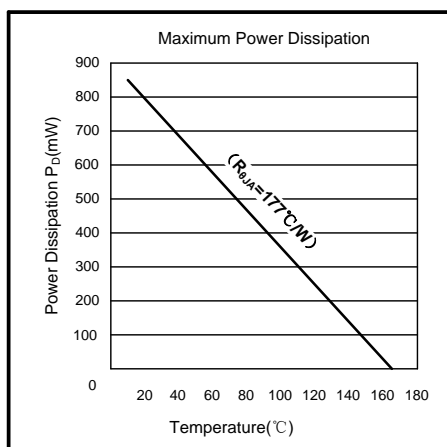

## OPERATING CHARACTERISTICS

### Electrical parameters

over operating free-air temperature range ( $V_{DD}=5V$ , unless otherwise noted)

Symbol	Parameter	Test Conditions	Min.	Typ.	Max.	Units
$V_{DD}$	Operating voltage	$T_J < T_{J(max)}$	3.8	--	24	V
$I_{DD}$	Operating supply current	$V_{DD}=3.8V$ to $24V$	4.5	6.5	8.5	mA
$V_{Qsat}$	Output saturation voltage	$I_Q=20mA$ , $T_A=25^\circ C$	--	150	400	mV
$I_{QL}$	Output leakage current	$V_{DD} < 24V$	--	--	10	$\mu A$
$V_{DZ}$	Overvoltage protection at $V_{DD}$ terminal	$I_{DD} = 10mA$	30	35	40	V
$V_{OZ}$	Overvoltage protection at OUT terminal	$V_Q = \text{High}$ $I_Q = 1mA$	30	35	40	V
OCP <sup>1</sup>	Over current protection at OUT terminal	$T_A=25^\circ C$	40	--	--	mA
$t_{po}$ <sup>2</sup>	Power-on time	$V_{DD}>3.8V$	--	3.8	9	mS
$t_{settle}$ <sup>3</sup>	Settling time	$V_{DD}>3.8V$ , $f=1kHz$	0	--	50	mS
$t_{response}$ <sup>4</sup>	Response time	$V_{DD}>3.8V$ , $f=1kHz$	3.8	--	59	mS
$t_r$ <sup>5</sup>	Output rise time	$R1=1Kohm$ $C_Q=20pF$	--	0.4	1.0	$\mu S$
$t_f$	Output fall time	$R1=1Kohm$ $C_Q=20pF$	--	0.35	1.0	$\mu S$
$f_{cu}$	Upper corner frequency	-3dB, single pole	--	20	--	kHz
$f_{cl}$	Lower corner frequency	-3dB, single pole	--	10	--	Hz

<sup>1</sup> $I_Q$  does not change state when  $I_Q=OCP$ .

<sup>2</sup>Time required to initialize device.

<sup>3</sup>Time required for the output switch points to be within specification.

<sup>4</sup>Equal to  $t_{po} + t_{settle}$ .

<sup>5</sup>Output Rise Time will be dominated by the RC time constant.

## Magnetic Characteristics

Symbol	Parameter	Test Conditions	Min.	Typ.	Max.	Units
$B_{Back}$	Pre-induction		-500	--	500	mT
$\Delta B_{OP1}$	Operated point of channel1	$f=1\text{kHz}, B_{diff}=5\text{mT}$	--	--	0	mT
$\Delta B_{RP1}$	Released point of channel1	$f=1\text{kHz}, B_{diff}=5\text{mT}$	0	--	--	mT
$B_{HYS1}$	Hysteresis of channel1		0.5	1.5	2.5	mT
$\Delta B_{M1}$	Center of switching point of channel1	$(B_{OP} + B_{RP}) / 2$	-2.0	0	+2.0	mT
$\Delta B_{OP2}$	Operated point of channel2	$f=1\text{kHz}, B_{diff}=5\text{mT}$	--	--	0	mT
$\Delta B_{RP2}$	Released point of channel2	$f=1\text{kHz}, B_{diff}=5\text{mT}$	0	--	--	mT
$B_{HYS2}$	Hysteresis of channel2		0.5	1.5	2.5	mT
$\Delta B_{M2}$	Center of switching point of channel1	$(B_{OP} + B_{RP}) / 2$	-2.0	0	+2.0	mT

## TYPICAL CHARACTERISTICS

**$I_{DD}$  vs  $V_{DD}$**

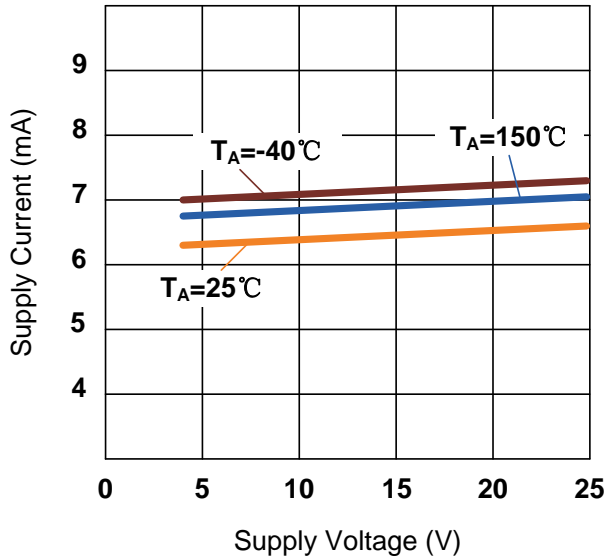

**$V_{Q(\text{sat})}$  vs  $T_A$**

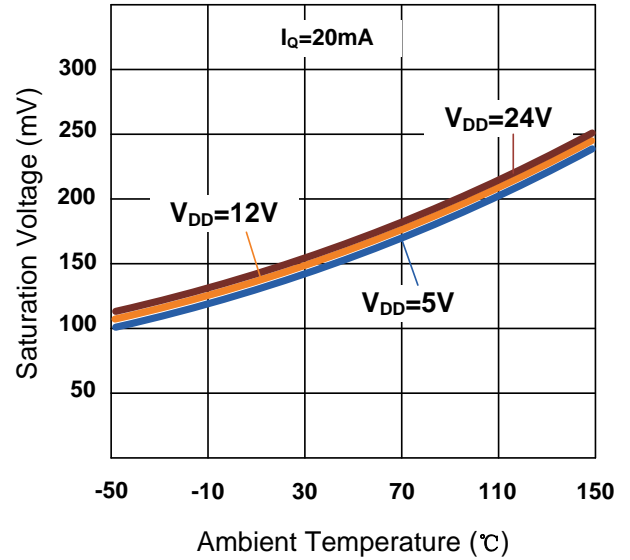

**$\Delta B_{M1/2}$  vs  $T_A$**

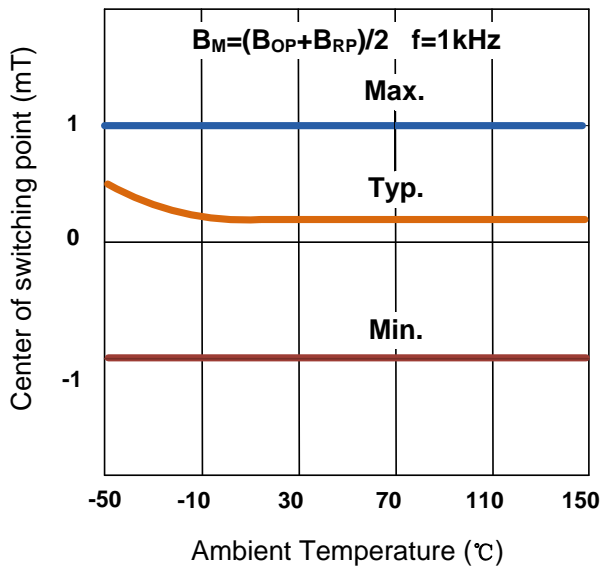

**$V_{HYS1/2}$  vs  $T_A$**

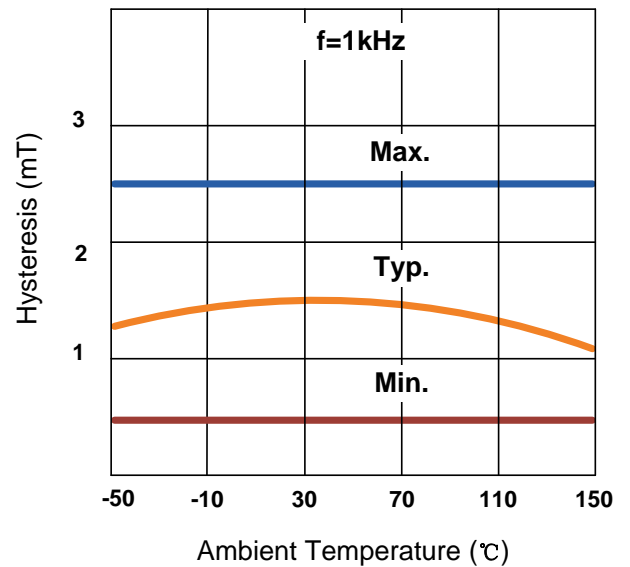



## FUNCTIONAL DESCRIPTION

The SC9632 integrates two independent differential Hall-effect sensor IC. The Hall IC supports four Hall elements, with magnet back-biased, which sense the magnetic profile of the ferrous gear target simultaneously, but at different points, generating two differential internal analog voltages, that is processed for precise switching of the digital output signals.

For each of two independent channels, the device detects the motion and position of ferromagnetic or permanent magnet structures by measuring the differential flux density of the magnetic field. Changes in field strength at the device face, which are induced by a moving target, are sensed by the two integrated Hall transducers. The transducers generate signals that are differentially amplified by on-chip electronics. This differential design provides immunity to radial vibration within the operating air gap range of the SC9632, by rejection of the common mode signal. Steady-state magnet and system offsets are eliminated using an on-chip differential band-pass filter. This filter also provides relative immunity to interference from electromagnetic sources.

The Hall IC is self-calibrating with a temperature compensated amplifier and offset cancellation circuitry. Its internal voltage regulator provides supply noise rejection throughout the operating voltage range. Changes in temperature do not greatly affect this device due to the stable amplifier design and the offset rejection circuitry. The Hall transducers and signal processing electronics are integrated on the same silicon substrate, using a proprietary BiCMOS process.

The SC9632 is offered in a lead (Pb) free 4-pin SIP package with a 100% matte tin plated lead frame.

## Power Derating Description

The device must be operated below the maximum junction temperature of the device,  $T_{J(max)}$ . Under certain combinations of peak condition, reliable operation may require derating supplied power or improving the heat dissipation properties of the application.

The package Thermal Resistance,  $R_{\theta JA}$ , is figure of merit summarizing the ability of the application and device to dissipate heat from the junction, through all paths to the ambient air. Its primary component is an Effective Thermal Conductivity,  $K$ , of the printed circuit board, including adjacent devices and traces. Radiation from the die through the device case,  $R_{\theta JC}$ , is relatively small component of  $R_{\theta JA}$ . Ambient air temperature,  $T_A$ , and air motion are significant external factors, damped by over-molding.

The effect of varying power levels (*Power Dissipation,  $P_D$* ), can be estimated. The following formulas represent the fundamental relationships used to estimate  $T_J$ , at  $P_D$ .

$$P_D = V_{DD} \times I_{DD} \quad (1)$$

$$\Delta T = P_D \times R_{\theta JA} \quad (2)$$

$$T_J = T_A + \Delta T \quad (3)$$

For example  $T_A = 25^\circ\text{C}$ ,  $V_{DD} = 5\text{V}$ ,  $I_{DD} = 6.5\text{mA}$ ,  $R_{\theta JA} = 177^\circ\text{C/W}$ .

$$\begin{aligned} P_D &= V_{DD} \times I_{DD} = 5\text{V} \times 6.5\text{mA} = 32.5\text{mW} \\ \Delta T &= P_D \times R_{\theta JA} = 32.5\text{mW} \times 177^\circ\text{C/W} = 5.8^\circ\text{C} \\ T_J &= T_A + \Delta T = 25^\circ\text{C} + 5.8^\circ\text{C} = 30.8^\circ\text{C} \end{aligned}$$

## Gear Tooth Sensing

In the case of ferromagnetic toothed wheel application, the IC has to be biased by the South or North pole of a permanent magnet which should cover both Hall probes

The maximum air gap depends on:

- the magnetic field strength (magnet used; pre-induction), and
- the toothed wheel that is used (dimensions, material, etc.)

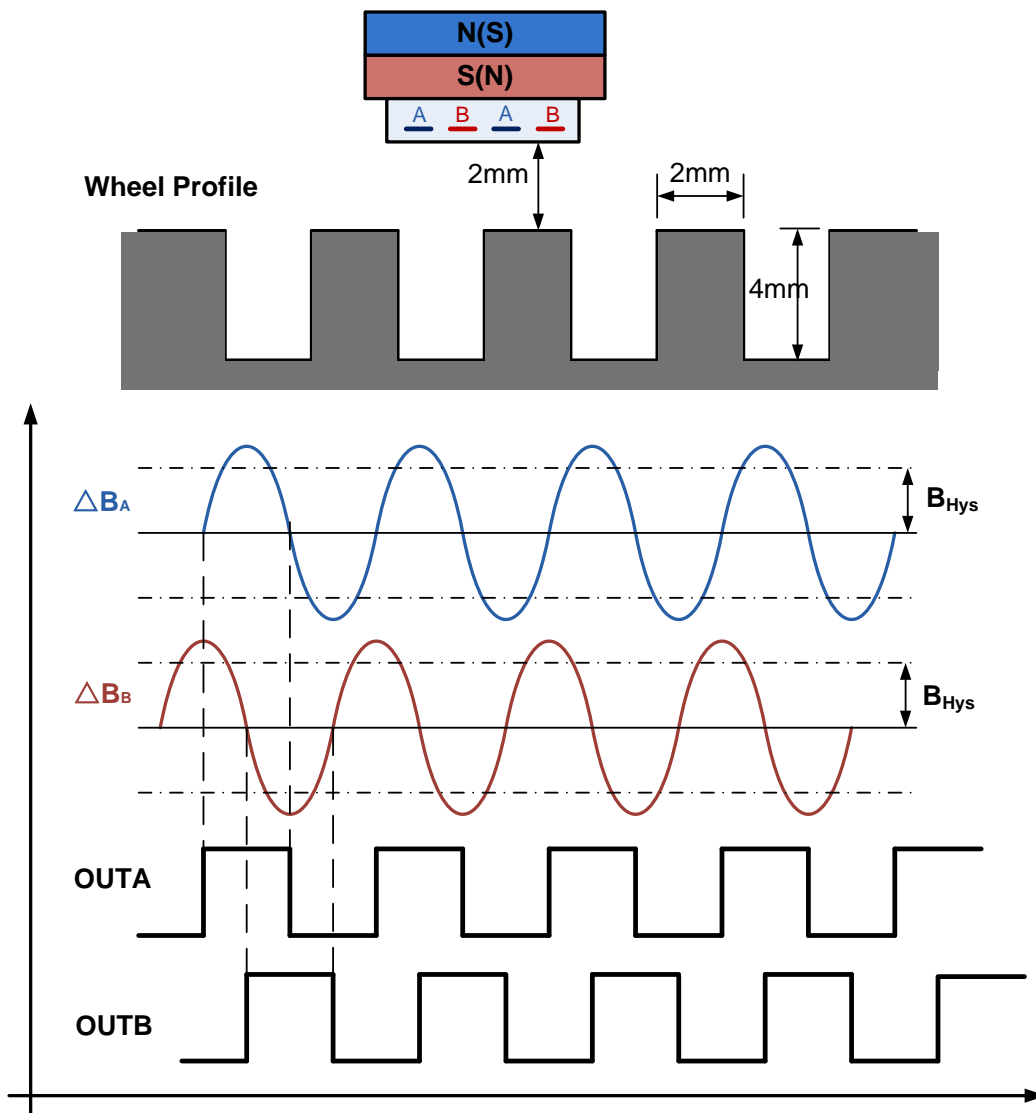

## TYPICAL APPLICATION

The SC9632 contains an on-chip voltage regulator and can operate over a wide supply voltage range. In applications that operate the device from an unregulated power supply, transient protection must be added externally, EMI/RFI protection may still be required.

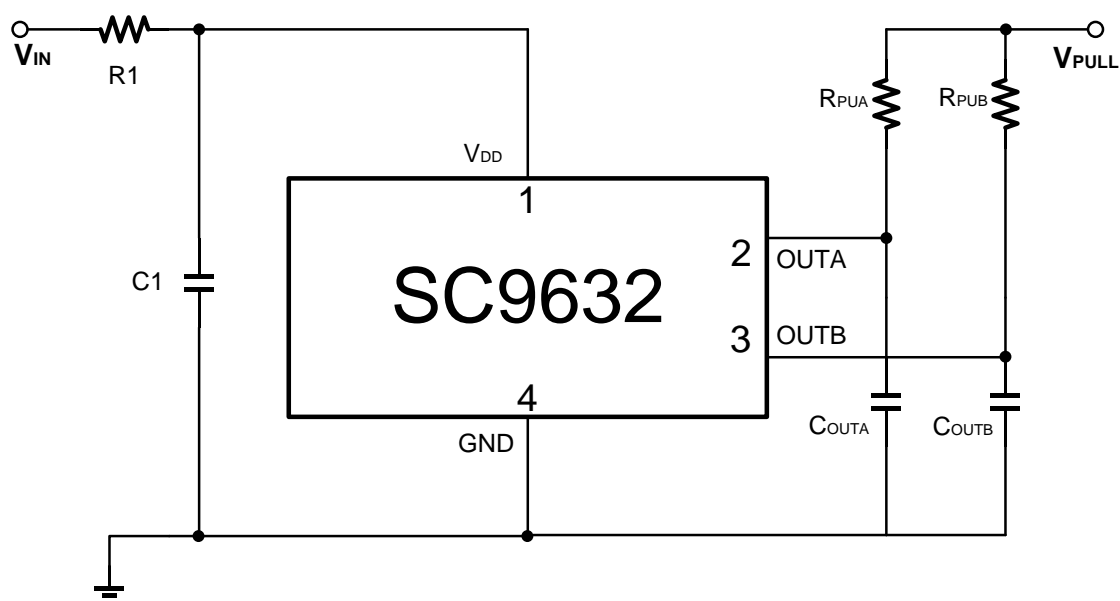

Component	Value	Units
$R_{PUA} / R_{PUB}$	2	$k\Omega$
R1	100	$\Omega$
C1	100	nF
$C_{OUTA} / C_{OUTB}$	1	nF

1. R1, C1 is for improved EMC performance

## PACKAGE INFORMATION

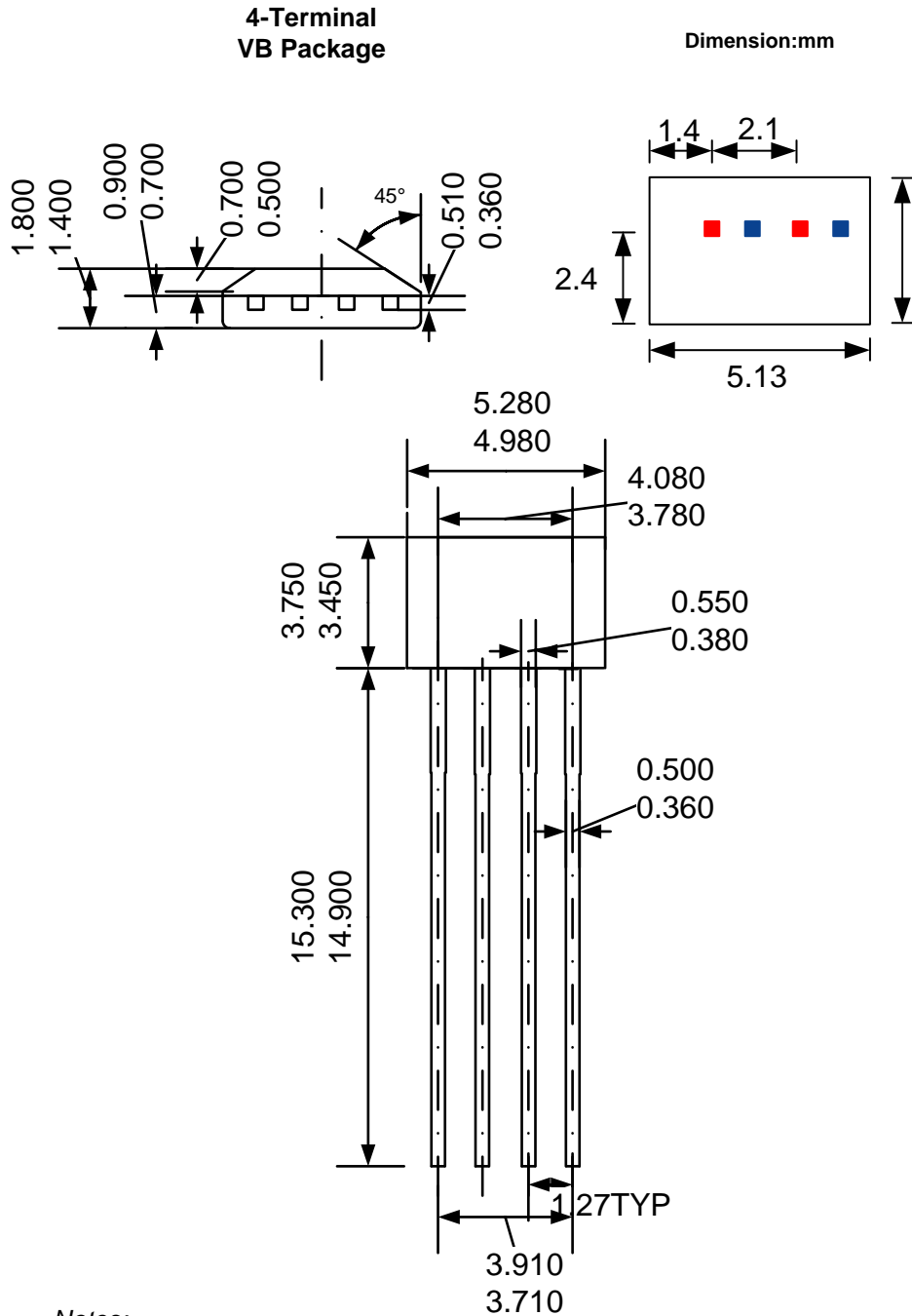

**Notes:**

1. Exact body and lead configuration at vendor's option within limits shown.
2. Height does not include mold gate flash.

Where no tolerance is specified, dimension is nominal.

## REVISION HISTORY

Revision	Date	Description
Rev0.1	2017-09-09	Preliminary datasheet
Rev2.3	2018-08-19	The final revision of old datasheet
RevA/1.0	2020-12-15	Unified datasheet format