

# S72MS-P based MCP/PoP Products

1.8 Volt-only x16 Flash Memory and SDRAM on Split Bus  
NAND Interface ORNAND™ Flash on Bus 1  
Mobile SDRAM on Bus 2



*Data Sheet (Advance Information)*

---

**Notice to Readers:** This document states the current technical specifications regarding the Spansion product(s) described herein. Each product described herein may be designated as Advance Information, Preliminary, or Full Production. See [Notice On Data Sheet Designations](#) for definitions.

## Notice On Data Sheet Designations

SpanSion Inc. issues data sheets with Advance Information or Preliminary designations to advise readers of product information or intended specifications throughout the product life cycle, including development, qualification, initial production, and full production. In all cases, however, readers are encouraged to verify that they have the latest information before finalizing their design. The following descriptions of SpanSion data sheet designations are presented here to highlight their presence and definitions.

### Advance Information

The Advance Information designation indicates that SpanSion Inc. is developing one or more specific products, but has not committed any design to production. Information presented in a document with this designation is likely to change, and in some cases, development on the product may discontinue. SpanSion Inc. therefore places the following conditions upon Advance Information content:

“This document contains information on one or more products under development at SpanSion Inc. The information is intended to help you evaluate this product. Do not design in this product without contacting the factory. SpanSion Inc. reserves the right to change or discontinue work on this proposed product without notice.”

### Preliminary

The Preliminary designation indicates that the product development has progressed such that a commitment to production has taken place. This designation covers several aspects of the product life cycle, including product qualification, initial production, and the subsequent phases in the manufacturing process that occur before full production is achieved. Changes to the technical specifications presented in a Preliminary document should be expected while keeping these aspects of production under consideration. SpanSion places the following conditions upon Preliminary content:

“This document states the current technical specifications regarding the SpanSion product(s) described herein. The Preliminary status of this document indicates that product qualification has been completed, and that initial production has begun. Due to the phases of the manufacturing process that require maintaining efficiency and quality, this document may be revised by subsequent versions or modifications due to changes in technical specifications.”

### Combination

Some data sheets contain a combination of products with different designations (Advance Information, Preliminary, or Full Production). This type of document distinguishes these products and their designations wherever necessary, typically on the first page, the ordering information page, and pages with the DC Characteristics table and the AC Erase and Program table (in the table notes). The disclaimer on the first page refers the reader to the notice on this page.

### Full Production (No Designation on Document)

When a product has been in production for a period of time such that no changes or only nominal changes are expected, the Preliminary designation is removed from the data sheet. Nominal changes may include those affecting the number of ordering part numbers available, such as the addition or deletion of a speed option, temperature range, package type, or  $V_{IO}$  range. Changes may also include those needed to clarify a description or to correct a typographical error or incorrect specification. SpanSion Inc. applies the following conditions to documents in this category:

“This document states the current technical specifications regarding the SpanSion product(s) described herein. SpanSion Inc. deems the products to have been in sufficient production volume such that subsequent versions of this document are not expected to change. However, typographical or specification corrections, or modifications to the valid combinations offered may occur.”

Questions regarding these document designations may be directed to your local sales office.

# S72MS-P based MCP/PoP Products

1.8 Volt-only x16 Flash Memory and SDRAM on Split Bus  
NAND Interface ORNAND™ Flash on Bus 1  
Mobile SDRAM on Bus 2



*Data Sheet (Advance Information)*

## Features

- Power supply voltage of 1.7 to 1.95V
- Flash access time: 25 ns for ORNAND Flash
- Mobile SDRAM burst frequency: 104 MHz (SDR), 133 MHz (DDR)
- ORNAND bus width: x8 or x16
- Package:
- 11.0 x 13.0 mm MCP
- Operating Temperature
- -25°C to +85°C (wireless)

The S72MS series is a product line of stacked packages and consists of:

- One or two NAND Interface ORNAND die
- Separate bus for one or more Mobile SDRAM die

The products covered by this document are listed in the table below.

Device	ORNAND Flash Density		DRAM Density		
	1024Mb	512Mb	512Mb	256Mb	128Mb
S72MS512PE0HF94V		X (x8)		X (x16 SDR)	

For detailed specifications, please refer to the individual data sheets.

Document	Publication Identification Number (PID)
S30MS-P	S30MS-P_00
256 Mb Mobile SDR-DRAM Type 5	SDRAM_10

## 1. Product Selector Guide

Device-Model#	ORNAND Flash Density	ORNAND Bus Width	ECC Required	DRAM Density	DRAM Speed	DRAM Supplier	Package
S72MS512PE0HF94V	512 Mb	x8	Yes	256 Mb	104 MHz (SDR)	Type 5	MCP 11x13mm 137-ball

## 2. Product Block Diagram

### 2.1 ORNAND Flash + DRAM MCP

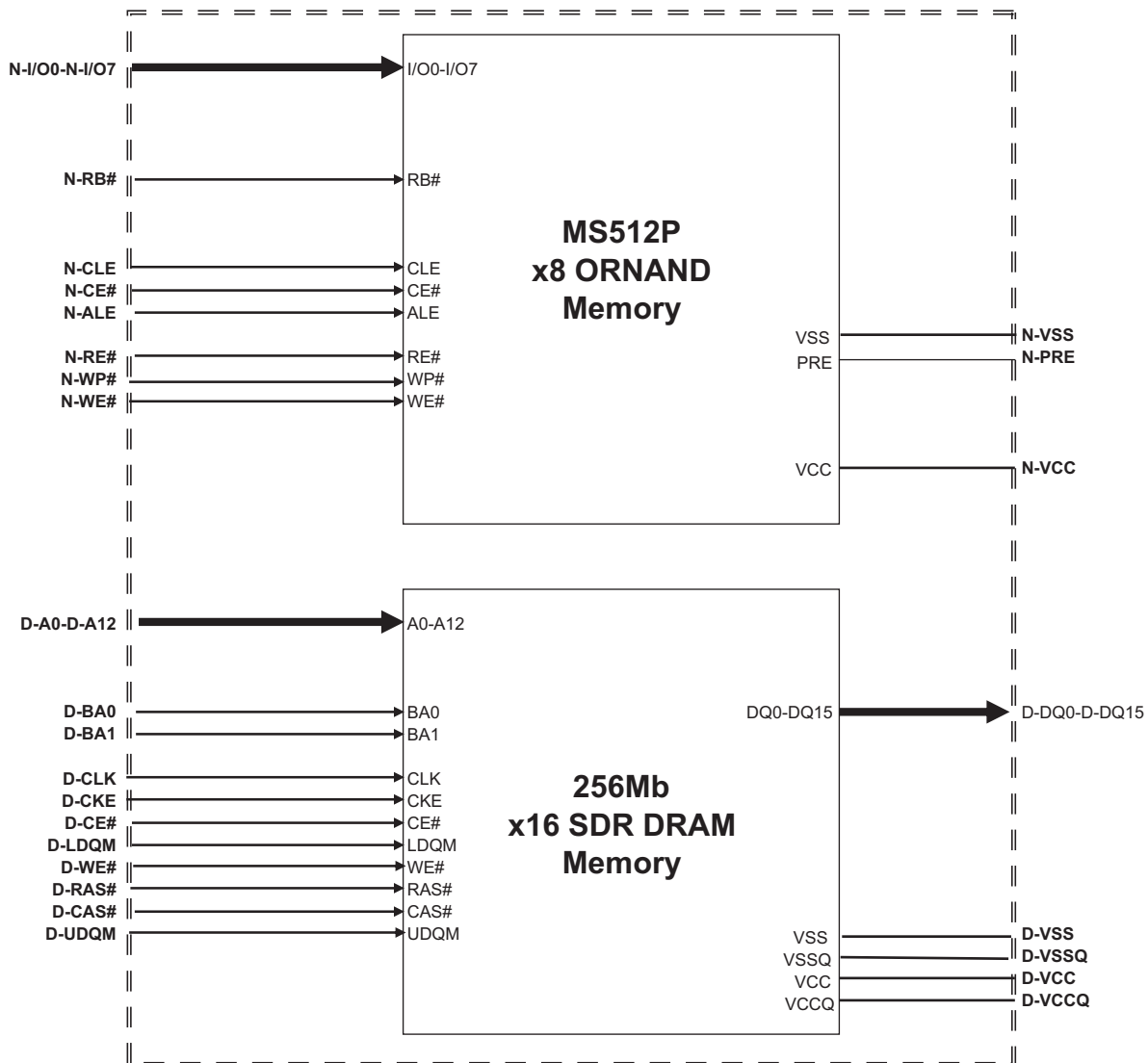

**Note**

1. For MCPs,  $V_{SS}$  is shared between all Flash (NOR and ORNAND). Also,  $V_{SSQ}$  is tied to  $V_{SS}$  internally within the MCP.

### 3. Connection Diagrams

#### 3.1 512 Mb x8 ORNAND Flash with 256 Mb DRAM

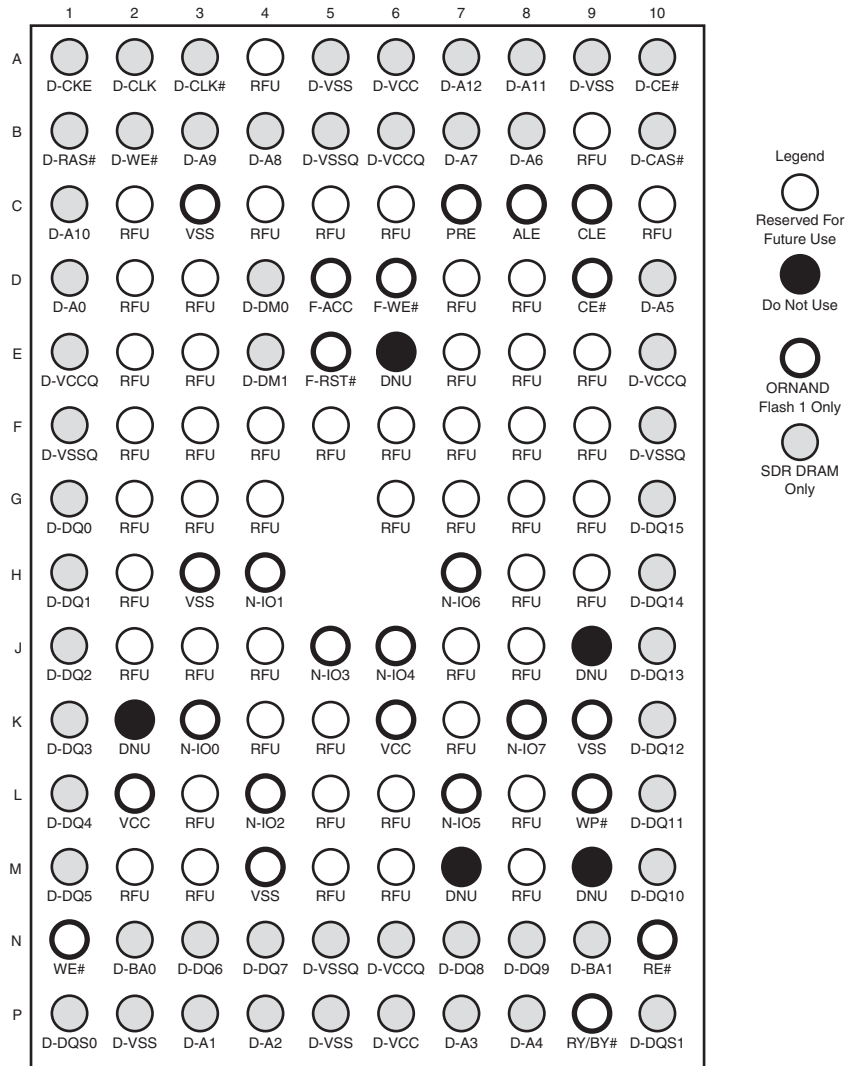

#### 3.1.1 Special Handling Instructions For FBGA Package

Special handling is required for Flash Memory products in FBGA packages.

Flash memory devices in FBGA packages may be damaged if exposed to ultrasonic cleaning methods. The package and/or data integrity may be compromised if the package body is exposed to temperatures above 150°C for prolonged periods of time.

#### 3.1.2 Look-ahead Ballout for Future Designs

Please refer to the Design-in Scalable Wireless Solutions with Spansion Products application note (publication number: Design\_Scalable\_Wireless\_A0\_E). Contact your local Spansion sales representative for more details.

## 3.2 DRAM Input/Output Descriptions

D-Amax-D-A0	SDRAM Address inputs
D-DQ15-D-DQ0	SDRAM Data input/output
D-CLK	SDRAM System Clock
D-CE#	SDRAM Chip Select
D-CKE	SDRAM Clock Enable
D-BA1-BA0	SDRAM Bank Select
D-RAS#	SDRAM Row Address Strobe
D-CAS#	SDRAM Column Address Strobe
D-DM1-D-DM0	SDRAM Data Input Mask
D-WE#	SDRAM Write Enable input
D-V <sub>SS</sub>	SDRAM Ground
D-CLK#	DDR SDRAM Clock - in addition to D-CLK, this signal is available for DDRAMs that need CLK# for normal operations
D-V <sub>SSQ</sub>	SDRAM Input/Output Buffer ground
D-V <sub>CCQ</sub>	SDRAM Input/Output Buffer power supply
D-V <sub>CC</sub>	SDRAM device power supply
D-DQS0 - D-DQS1	DDR SDRAM Data Strobe pins. DQS provides the read data strobes (as output) and the write data strobes (as input). Each DQS pin corresponds to eight DQ pins, respectively.

**Note**

Some of the signal descriptions specifically apply to DDR DRAM only.

### 3.2.1 ORNAND Signal Descriptions

N-PRE	ORNAND Power-On Read Enable. Tie to V <sub>SS</sub> on customer board if not used
N-ALE	ORNAND Address Latch Enable
N-CLE	ORNAND Command Latch Enable
N-CE#	ORNAND Chip-enable
N-WP#	ORNAND Write-protect
N-WE#	ORNAND Write-enable
N-RE#	ORNAND Read-enable
N-RY/BY#	ORNAND Ready-Busy
N-I/O0-N-I/O15	ORNAND I/O Signals (I/O0-I/O7 for x8 bus width)
N-V <sub>CC</sub>	ORNAND Power Supply

## 4. Ordering Information

The order number is formed by a valid combinations of the following:

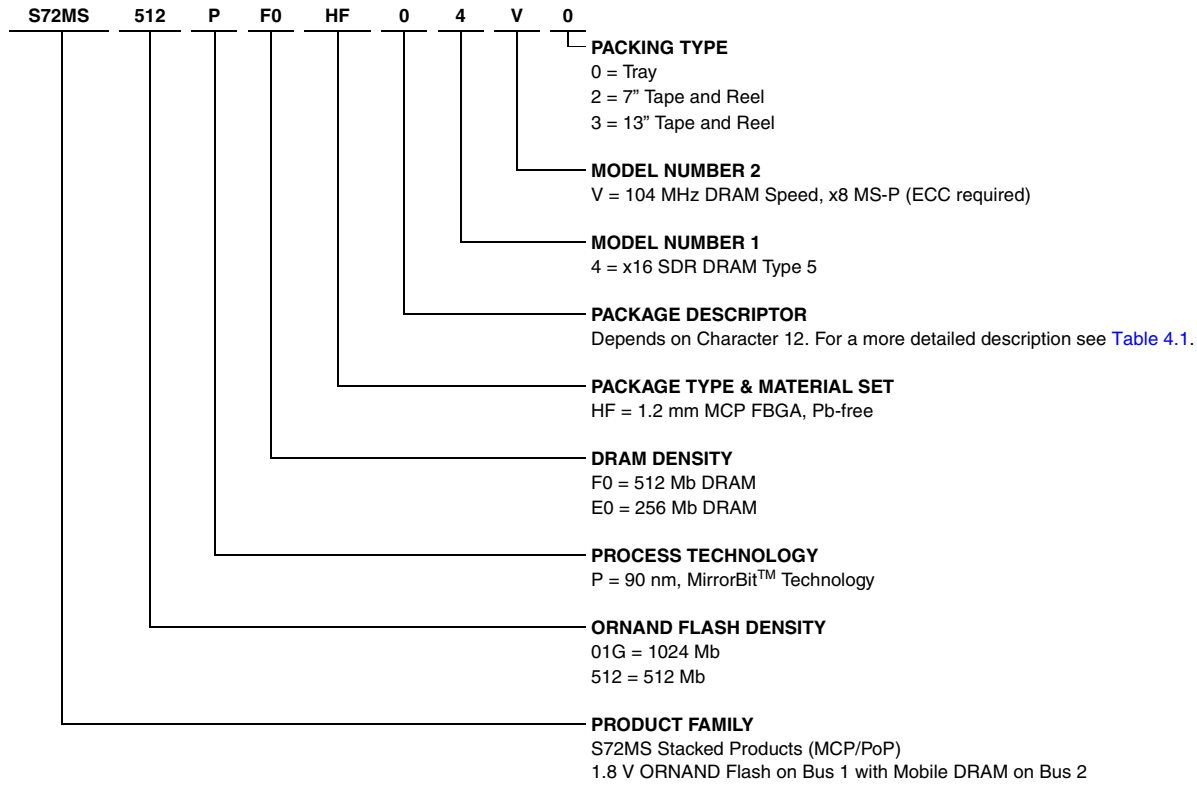

**Table 4.1** Character Position Descriptions (Sheet 1 of 2)

Character 12	Character 13	Character 14 Description		
		Package Area	Package Ball Count	Raw Ball Size
H, J, or G	0	7x9 mm	56	0.35 mm
	1	7x9 mm	80	
	2	8x11.6 mm	64	
	3	8x11.6 mm	84	
	4	9x12 mm	84	
	5	9x12 mm	115	
	6	9x12 mm	137	
	7	11x13 mm	84	
	8	11x13 mm	115	
	9	11x13 mm	137	

**Table 4.1** Character Position Descriptions (Sheet 2 of 2)

Character 12	Character 13	Character 14 Description		
		Package Area	Package Ball Count	Raw Ball Size
K	A	11x11 mm	112	0.45 mm
	B	11x11 mm	112	0.50 mm
	D	12x12 mm	128	0.45 mm
	F	12x12 mm	128	0.50 mm
	G	14x14 mm	152	0.45 mm
	H	14x14 mm	152	0.50 mm
	J	15x15 mm	160	0.45 mm
	K	15x15 mm	160	0.50 mm
	L	17x17 mm	192	0.45 mm
	M	17x17 mm	192	0.50 mm

## 4.1 Valid Combinations

Valid Combinations list configurations planned to be supported in volume for this device. Consult your local sales office to confirm availability of specific valid combinations and to check on newly released combinations.

S72MS-P Valid Combinations				ORNAND Flash Bus Width	DRAM Supplier	DRAM Speed	Package Type	Package Markings
Base Ordering Number	Package & Material Set	Package Descriptor	Packing Type					
S72MS512PE0	HF	9	0, 2, 3 (Note 1)	x8 (ECC)	Type 5	104 MHz	11x13 mm (MCP)	(Note 2)

**Notes:**

1. Packing Type 0 is standard. Specify other options as required.
2. BGA package marking omits leading S and packing type designator from ordering part number.



## 5. Physical Dimensions

### 5.1 TLK137—137-ball Fine-Pitch Ball Grid Array (FBGA) 13 x 11 mm Package

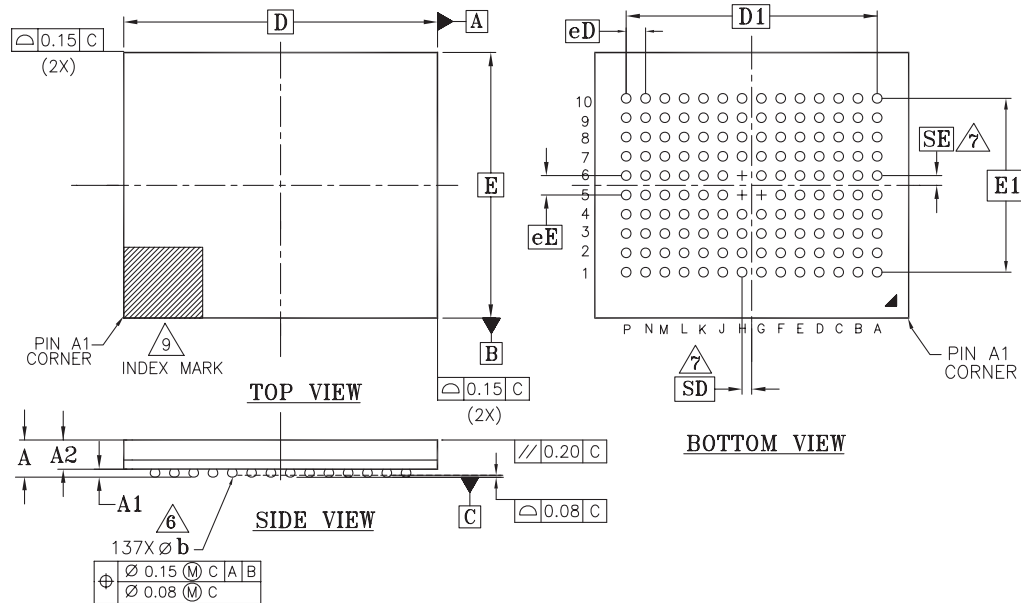

NOTES:

- DIMENSIONING AND TOLERANCING METHODS PER ASME Y14.5M-1994.
- ALL DIMENSIONS ARE IN MILLIMETERS.
- BALL POSITION DESIGNATION PER JEP95, SECTION 4.3, SPP-010.
- $e$  REPRESENTS THE SOLDER BALL GRID PITCH.
- SYMBOL "MD" IS THE BALL MATRIX SIZE IN THE "D" DIRECTION.  
SYMBOL "ME" IS THE BALL MATRIX SIZE IN THE "E" DIRECTION.  
n IS THE NUMBER OF POPULATED SOLDER BALL POSITIONS FOR MATRIX SIZE MD X ME.
- DIMENSION "b" IS MEASURED AT THE MAXIMUM BALL DIAMETER IN A PLANE PARALLEL TO DATUM C.
- SD AND SE ARE MEASURED WITH RESPECT TO DATUMS A AND B AND DEFINE THE POSITION OF THE CENTER SOLDER BALL IN THE OUTER ROW.  
WHEN THERE IS AN ODD NUMBER OF SOLDER BALLS IN THE OUTER ROW SD OR SE = 0.000.  
WHEN THERE IS AN EVEN NUMBER OF SOLDER BALLS IN THE OUTER ROW, SD OR SE =  $e/2$ .
- "+" INDICATES THE THEORETICAL CENTER OF DEPOPULATED BALLS.
- A1 CORNER TO BE IDENTIFIED BY CHAMFER, LASER OR INK MARK, METALLIZED MARK INDENTATION OR OTHER MEANS.

PACKAGE	TLK 137			NOTE
JEDEC	N/A			
D x E	13.00 mm x 11.00 mm PACKAGE			
SYMBOL	MIN	NOM	MAX	
A	---	---	1.20	PROFILE
A1	0.17	---	---	BALL HEIGHT
A2	0.79	---	0.96	BODY THICKNESS
D	13.00 BSC.			BODY SIZE
E	11.00 BSC.			BODY SIZE
D1	10.40 BSC.			MATRIX FOOTPRINT
E1	7.20 BSC.			MATRIX FOOTPRINT
MD	14			MATRIX SIZE D DIRECTION
ME	10			MATRIX SIZE E DIRECTION
n	137			BALL COUNT
Øb	0.35	0.40	0.45	BALL DIAMETER
eE	0.80 BSC.			BALL PITCH
eD	0.80 BSC.			BALL PITCH
SD SE	0.40 BSC.			SOLDER BALL PLACEMENT
	G5,H5,H6			DEPOPULATED SOLDER BALLS

3606 \ 16-038.43 \ 9.14.06

## 6. Revision History

### 6.1 Revision 01 (September 14, 2006)

Initial release.

#### ***Colophon***

The products described in this document are designed, developed and manufactured as contemplated for general use, including without limitation, ordinary industrial use, general office use, personal use, and household use, but are not designed, developed and manufactured as contemplated (1) for any use that includes fatal risks or dangers that, unless extremely high safety is secured, could have a serious effect to the public, and could lead directly to death, personal injury, severe physical damage or other loss (i.e., nuclear reaction control in nuclear facility, aircraft flight control, air traffic control, mass transport control, medical life support system, missile launch control in weapon system), or (2) for any use where chance of failure is intolerable (i.e., submersible repeater and artificial satellite). Please note that Spansion will not be liable to you and/or any third party for any claims or damages arising in connection with above-mentioned uses of the products. Any semiconductor devices have an inherent chance of failure. You must protect against injury, damage or loss from such failures by incorporating safety design measures into your facility and equipment such as redundancy, fire protection, and prevention of over-current levels and other abnormal operating conditions. If any products described in this document represent goods or technologies subject to certain restrictions on export under the Foreign Exchange and Foreign Trade Law of Japan, the US Export Administration Regulations or the applicable laws of any other country, the prior authorization by the respective government entity will be required for export of those products.

#### ***Trademarks and Notice***

The contents of this document are subject to change without notice. This document may contain information on a Spansion product under development by Spansion. Spansion reserves the right to change or discontinue work on any product without notice. The information in this document is provided as is without warranty or guarantee of any kind as to its accuracy, completeness, operability, fitness for particular purpose, merchantability, non-infringement of third-party rights, or any other warranty, express, implied, or statutory. Spansion assumes no liability for any damages of any kind arising out of the use of the information in this document.

Copyright © 2006 Spansion Inc. All Rights Reserved. Spansion, the Spansion logo, MirrorBit, ORNAND, HD-SIM, and combinations thereof are trademarks of Spansion Inc. Other names are for informational purposes only and may be trademarks of their respective owners.