



RVT70UQTNWC0x

LCD TFT Datasheet

Rev.2.1

2017-02-27

ITEM	CONTENTS	UNIT
LCD Type	TFT/Transmissive/Normally white	/
Size	7.0	Inch
Viewing Direction	12:00 (without image inversion)	O' Clock
Gray Scale Inversion Direction	6:00	O' Clock
LCM (W × H × D)	164.80 × 99.80 × 7.80	mm3
Active Area (W × H)	154.08 × 85.92	mm2
Dot Pitch (W × H)	0.1926 × 0.179	mm2
Number of Dots	800 (RGB) × 480	/
Driver IC	HX8264+HX8664	/
Backlight Type	21 LEDs	/
Surface Luminance	350	cd/m2
Interface Type	24bit RGB	/
Color Depth	16.7M	/
Pixel Arrangement	RGB Vertical Stripe	/
Surface Treatment	Clear	
Input Voltage	3.3	V
With/Without TSP	Projected Capacitive Touch Panel	/
Weight	199	g

Note 1: RoHS compliant

Note 2: LCM weight tolerance: ± 5%.

REVISION RECORD

REVNO.	REVDATE	CONTENTS	REMARKS
1.0	2015-02-19	Initial Release	
1.1	2015-03-31	Surface Treatment Data Correction	
2.0	2016-10-17	New PCT controller	
2.1	2017-02-27	Updated mechanical drawing	

CONTENTS

REVISION RECORD.....	2
CONTENTS	3
1 MODULE CLASSIFICATION INFORMATIO.....	4
2 MODULE DRAWING	4
3 ABSOLUTE MAXIMUM RATINGS.....	5
4 ELECTRICAL CHARACTERISTICS.....	5
5 BACKLIGHT CHARACTERISTICS	5
6 ELECTRO-OPTICAL CHARACTERISTICS	5
7 INTERFACE DESCRIPTION	7
8 LCD TIMING CHARACTERISTICS	10
8.1 Clock and data input time diagram	10
8.2 Parallel RGB input timing table	10
9 CAPACITIVE TOUCH SCREEN PANEL SPECIFICATIONS	11
9.1 Mechanical characteristics	11
9.2 Electrical characteristics	11
9.3 Interface description	11
9.4 Interface timing characteristics.....	12
9.5 I2C Read/Write Interface Description	12
9.6 Communication of the I ² C interface with Host	13
9.7 Touch data read protocol.....	13
9.8 Data description.	14
9.9 Interrupt Trigger Mode	15
10 ORDERING INFORMATION	16
11 CUSTOMIZATION LEVEL.....	17
12 INSPECTION	18
12.1 Inspection condition.....	18
12.2 Inspection standard.....	19
13 RELIABILITY TEST	22
LEGAL INFORMATION.....	23

1 MODULE CLASSIFICATION INFORMATIO

RV	T	7.0	A	800480	T	N	W	C	00
1.	2.	3.	4.	5.	6.	7.	8.	9.	10.

1.	BRAND	RV – Riverdi
2.	PRODUCT TYPE	T – TFT Standard F – TFT Custom
3.	DISPLAY SIZE	3.5 – 3.5” 4.3 – 4.3” 5.7 – 5.7” 7.0 – 7.0”
4.	MODEL SERIAL NO.	A (A-Z)
5.	RESOLUTION	320240 – 320x240 px 480272 – 480x272 px 800480 – 800x480 px
6.	INTERFACE	T – TFT LCD, RGB L – TFT LCD, LVDS C – TFT + Controller
7.	FRAME	N – No Frame F – Mounting Frame
8.	BACKLIGHT TYPE	W – LED White
9.	TOUCH PANEL	N – No Touch Panel R – Resistive Touch Panel C – Capacitive Touch Panel
10.	VERSION	00 (00-99)

PIN DESCRIPTION			
PIN NO	SYMBOL	PIN NO	SYMBOL
1	VLED+	26	G1
2	VLED+	27	G0
3	VLED-	28	R7
4	VLED-	29	R6
5	GND	30	R5
6	VDD	31	R4
7	VDD	32	R3
8	MODE	33	R2
9	DE	34	R1
10	VSYNC	35	R0
11	HSYNC	36	GND
12	B7	37	DCLK
13	B6	38	GND
14	B5	39	LR
15	B4	40	UD
16	B3	41	VDD
17	B2	42	VDD
18	B1	43	NC
19	B0	44	RESET
20	G7	45	NC
21	G6	46	NC
22	G5	47	DITHB
23	G4	48	GND
24	G3	49	NC
25	G2	50	NC

Internal Backlight LED Circuit

NOTES:

1. DISPLAY TYPE: TFT, TRANSMISSIVE, NORMALLY WHITE
2. 7.0 INCH PROJECTIVE CAPACITIVE TOUCH PANEL.
3. OPERATION VOLTAGE: VDD=3.3V
4. VIEWING DIRECTION: 12 O'CLOCK
5. LED BACKLIGHT: 21-LED WHITE, BUILT-IN INVERTER
6. IC CONTROLLER: FT813
7. CTP IC DRIVER: FT5406
8. CTP MULTI FINGER: UP TO 5
9. OPERATING TEMP.: -20°C ~ 70°C
10. STORAGE TEMP.: -30°C ~ 80°C
11. SURFACE LUMINANCE: 350 cd/m²
12. GENERAL TOLERANCE: ±0.2
13. RoHS COMPLIANT

DETAIL A SCALE 60:1

DETAIL B SCALE 4:1

CUSTOMER APVL		DATE	2017/02/27
DRAWN	SCALE	TITLE	RV70UQNNWC0x
DFTG CHK	UNIT	MODEL	
ENGR CHK	mm	DWG NO	REV,1,0
APPROVAL		PAGE	1/1

Ver.	DESCRIPTION	DATE
1.1	Updated pinout	2017.02.27
1.0	Initial case	2016.10.17

3 ABSOLUTE MAXIMUM RATINGS

PARAMETER	SYMBOL	MIN	MAX	UNIT
Supply Voltage for Logic	VDD	-0.3	5.0	V
LED reverse voltage (each LED)	VR	-	1.2	V
LED forward voltage (each LED)	IF	-	30	mA
Operating Temperature	T _{OP}	-20	70	°C
Storage Temperature	T _{ST}	-30	80	°C

4 ELECTRICAL CHARACTERISTICS

PARAMETER	SYMBOL	MIN	TYP	MAX	UNIT
Power voltage	VDD	3.0	3.3	3.6	V
Input Current	IVDD	-	71.4	-	mA
Input Voltage 'H' level	V _{IH}	0.7VDD	-	VDD	V
Input Voltage 'L' level	V _{IL}	0	-	0.3VDD	V

5 BACKLIGHT CHARACTERISTICS

ITEM	SYMBOL	MIN	TYP	MAX	UNIT
Voltage for LED backlight	V _I	9.0	9.6	10.2	V
Current for LED backlight	I _I	170	180	200	mA
LED Life Time	-	30000	50000	-	Hrs

Note: The LED life time is defined as the module brightness decrease to 50% original brightness at Ta=25°C.

6 ELECTRO-OPTICAL CHARACTERISTICS

ITEM	SYMBOL	CONDITION	MIN	TYP	MAX	UNIT	REMARK	NOTE
Response Time	Tr+Tf	θ=0° ∅=0° Ta=25	-	20	35	ms	FIG 1.	4
Contrast Ratio	Cr		400	500	-	---	FIG 2.	1
Luminance Uniformity	δ WHITE		70	75	-	%	FIG 2.	3
Surface Luminance	Lv		-	350	-	cd/m ²	FIG 2.	2
Viewing Angle Range	θ	∅ = 90°	40	50	-	deg	FIG 3.	6
		∅ = 270°	60	70	-	deg	FIG 3.	
		∅ = 0°	60	70	-	deg	FIG 3.	
		∅ = 180°	60	70	-	deg	FIG 3.	
CIE (x, y) Chromaticity	Red	θ=0° ∅=0° Ta=25	x	-	-	-	FIG 2.	5
			y	-	-	-		
	Green		x	-	-	-		
			y	-	-	-		
	Blue		x	-	-	-		
			y	-	-	-		
	White		x	-	0.280	-		
			y	-	0.310	-		

Note 1. Contrast Ratio(CR) is defined mathematically as below, for more information see Figure 1.

$$\text{Contrast Ratio} = \frac{\text{Average Surface Luminance with all white pixels (P1, P2, P3, P4, P5)}}{\text{Average Surface Luminance with all black pixels (P1, P2, P3, P4, P5)}}$$

Note 2. Surface luminance is the LCD surface from the surface with all pixels displaying white. For more information see Figure 2.

L_v = Average Surface Luminance with all white pixels (P1, P2, P3, P4, P5)

Note 3. The uniformity in surface luminance δ WHITE is determined by measuring luminance at each test position 1 through 5, and then dividing the maximum luminance of 5 points luminance by minimum luminance of 5 points luminance. For more information see Figure 2.

$$\delta \text{ WHITE} = \frac{\text{Minimum Surface Luminance with all white pixels (P1, P2, P3, P4, P5)}}{\text{Maximum Surface Luminance with all white pixels (P1, P2, P3, P4, P5)}}$$

Note 4. Response time is the time required for the display to transition from white to black (Rise Time, T_r) and from black to white (Decay Time, T_f). For additional information see FIG 1. The test equipment is Autronic-Melchers's ConoScope series.

Note 5. CIE (x, y) chromaticity, the x, y value is determined by measuring luminance at each test position 1 through 5, and then make average value.

Note 6. Viewing angle is the angle at which the contrast ratio is greater than 2. For TFT module the contrast ratio is greater than 10. The angles are determined for the horizontal or x axis and the vertical or y axis with respect to the z axis which is normal to the LCD surface. For more information see Figure 3.

Note 7. For viewing angle and response time testing, the testing data is based on Autronic-Melchers's ConoScope series. Instruments for Contrast Ratio, Surface Luminance, Luminance Uniformity, CIE the test data is based on TOPCON's BM-5 photo detector.

Figure 1. The definition of response time

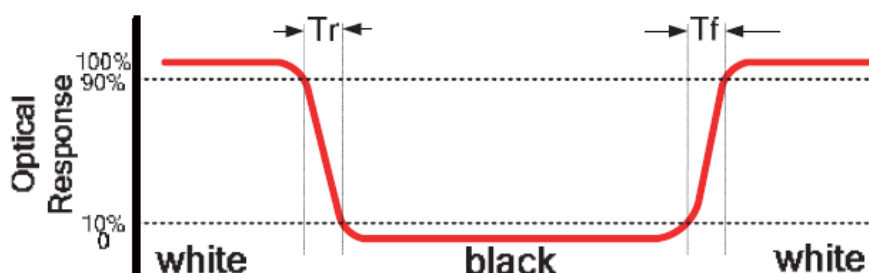

Figure 2. Measuring method for Contrast ratio, surface luminance, luminance uniformity, CIE (x, y) chromaticity

A : 5 mm
 B : 5 mm
 H, V : Active Area
 Light spot size $\varnothing=5\text{mm}$, 500mm distance from the LCD surface to detector lens
 measurement instrument is TOPCON's luminance meter BM-5

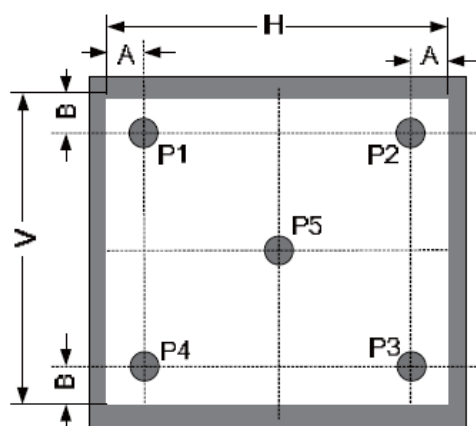
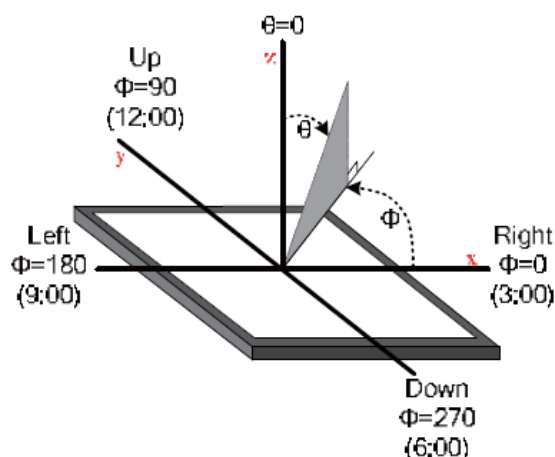

Figure 3. The definition of viewing angle



7 INTERFACE DESCRIPTION

PIN NO.	SYMBOL	DESCRIPTION	REMARK
1	VLED+	Anode Of LED Backlight	
2	VLED+	Anode Of LED Backlight	
3	VLED-	Cathode Of LED Backlight	
4	VLED-	Cathode Of LED Backlight	
5	GND	Power Ground	
6	VCC	Power For Circuit	
7	VCC	Power For Circuit	
8	MODE	DE/SYNC Mode Select	Note 1
9	DE	Data Input Enable	
10	VSNC	Vertical Sync Signal	
11	HSNC	Horizontal Sync Signal	
12	B7	Blue Data (MSB)	
13	B6	Blue Data	
14	B5	Blue Data	
15	B4	Blue Data	

16	B3	Blue Data	
17	B2	Blue Data	
18	B1	Blue Data	Note 2
19	B0	Blue Data (LSB)	Note 2
20	G7	Green Data (MSB)	
21	G6	Green Data	
22	G5	Green Data	
23	G4	Green Data	
24	G3	Green Data	
25	G2	Green Data	
26	G1	Green Data	Note 2
27	G0	Green Data (LSB)	Note 2
28	R7	Red Data (MSB)	
29	R6	Red Data	
30	R5	Red Data	
31	R4	Red Data	
32	R3	Red Data	
33	R2	Red Data	
34	R1	Red Data	Note 2
35	R0	Red Data (LSB)	Note 2
36	GND	Power Ground	
37	DCLK	Clock For Input Data	Note 3
38	GND	Power Ground	
39	LR	Left / Right Selection	Note 4,5,8
40	UD	Up / Down Selection	Note 4,5,9
41	VDD	Power For Circuit	
42	VDD	Power For Circuit	
43	NC	No Connection	
44	RESET	Global Reset Pin	Note 6
45	NC	No Connection	
46	NC	No Connection	
47	DITHB	Dithering Function	Note 7
48	GND	Power Ground	
49	NC	No Connection	
50	NC	No Connection	

Note 1: DE/SYNC mode select. Normally (internally) pulled high.

When select DE mode, MODE="1", VS and HS must pull high.

When select SYNC mode, MODE="0", DE must be grounded.

Note 2: When input 18bit RGB data, the two low bits of R, G and B data must be grounded.

Note 3: Data shall be latched at the falling edge of DCLK.

Note 4: Selection of scanning mode.

SET OF SCAN CONTROL INPUT		SCANNING DIRECTION
UD	LR	
GND	VDD	Up To Down, Left To Right
VDD	GND	Down To Up, Right To Left
GND	GND	Up To Down, Right To Left
VDD	VDD	Down To Up, Left To Right

Note 5: Definition of scanning direction.

Refer to the Figure 4.

Figure 4. Definition of scanning direction

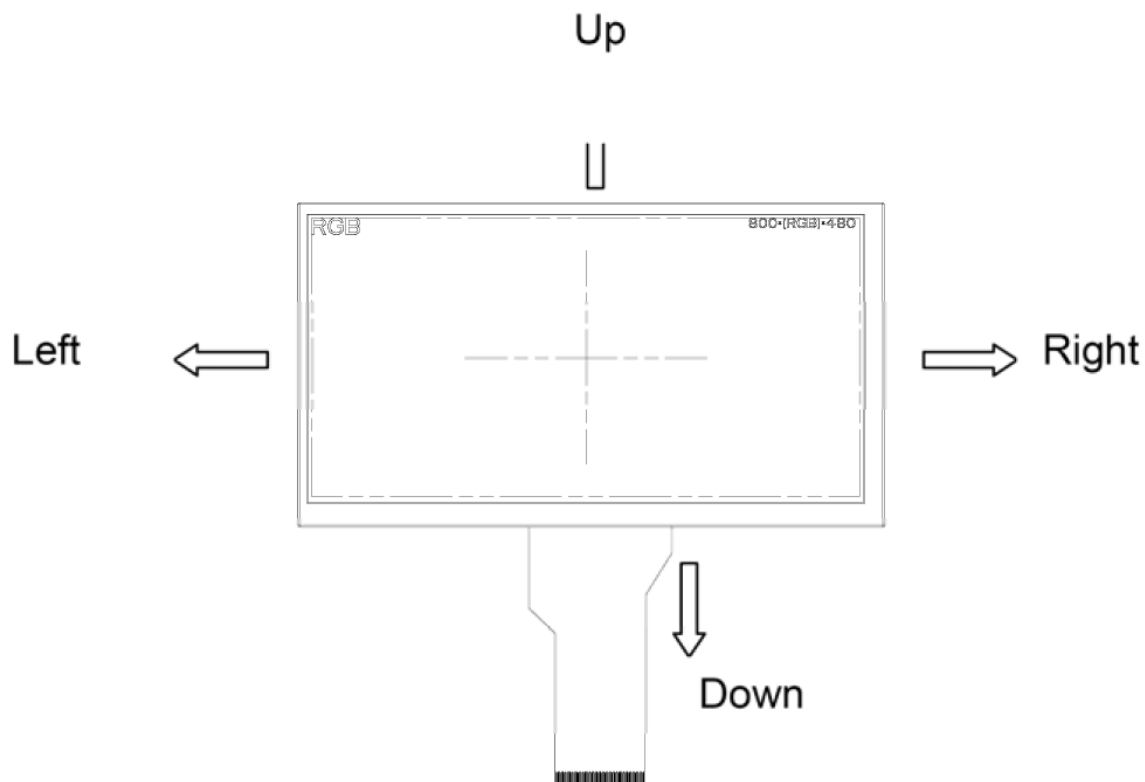

Note 6: Global reset pin. Active low to enter reset state. Suggest to connect with an RC reset circuit for stability. Normally (internally) pulled high.

Note 7: Dithering function enable control, normally (internally) pull high.

When DITHB="1", Disable internal dithering function,

When DITHB="0", Enable internal dithering function,

Note 8: Normally (internally) pull high.

Note 9: Normally(internally) pull low.

8 LCD TIMING CHARACTERISTICS

8.1 Clock and data input time diagram

Figure 5. Horizontal input timing diagram.



Figure 6. Vertical input timing diagram

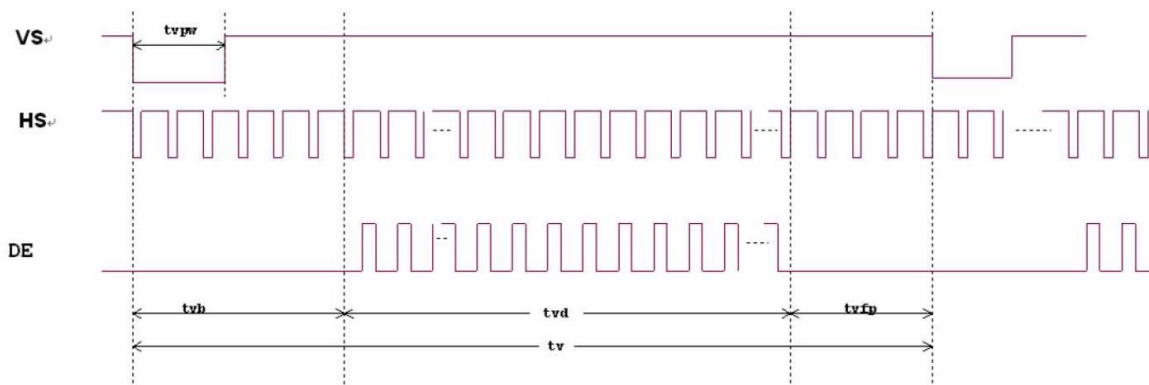

8.2 Parallel RGB input timing table

PARAMETER	SYMBOL	MIN	TYP	MAX	UNIT
DCLK Frequency	Fclk	26.4	33.3	46.8	MHz
VSD Period Time	Tv	510	525	650	TH
VSD Display Area	Tvd		480		TH
VSD Blanking	Tvb		23		TH
VSD Front Porch	Tvfp	7	22	147	TH
VSD Pulse Width	Tvpw	1	-	20	TH
HSD Pulse Width	Thpw	1	-	40	DCLK
HSD Period Time	Th	862	1056	1200	DCLK
HSD Display Area	Thd		800		DCLK
HSD Blanking	Thb		46		DCLK
HSD Front Porch	Thfp	16	210	354	DCLK

9 CAPACITIVE TOUCH SCREEN PANEL SPECIFICATIONS

9.1 Mechanical characteristics

DESCRIPTION	INL SPECIFICATION	REMARK
Touch Panel Size	7 inch	
Outline Dimension (OD)	164.4mm x 99.45mm	Cover Lens Outline
Product Thickness	2.3mm	
Glass Thickness	1.1mm	
Ink View Area	155.08mm x 87.42mm	
Sensor Active Area	156.68mm x 88.52mm	
Input Method	5 Finger	
Activation Force	Touch	
Surface Hardness	≥7H	

9.2 Electrical characteristics

DESCRIPTION	SPECIFICATION	
Operating Voltage	DC 2.8~3.3V	
Power Consumption (IDD)	Active Mode	10~18mA
	Sleep Mode	30~50μA
Interface	I ² C	
Linearity	<1.5%	
Controller	FT5426	
I2C address	0x38 (7 bit address)	
Resolution	1792*1024	

9.3 Interface description

PIN NO.	SYMBOL	DESCRIPTION	REMARK
1	VSS	Power Ground	
2	VDD	Power For CTP	
3	SCL	I2C SCL	
4	NC	-	
5	SDA	I2C SDA	
6	NC	-	
7	/RST	Reset pin	
8	/WAKE	Wake signal from host	
9	/INT	Interrupt signal from CTP	
10	VSS	Power Ground	

9.4 Interface timing characteristics

PARAMETER	MIN	MAX	UNIT
SCL Frequency	0	400	kHz
Bus Free Time Between a STOP and START Condition	4.7	/	μs
Hold Time (repeated) START Condition	4.0	/	μs
Data Setup Time	250	/	ns
Setup Time for Repeated START Condition	4.7	/	μs
Setup Time for STOP Condition	4.0	/	μs

9.5 I2C Read/Write Interface Description

Figure 7. Write N bytes to I2C slave

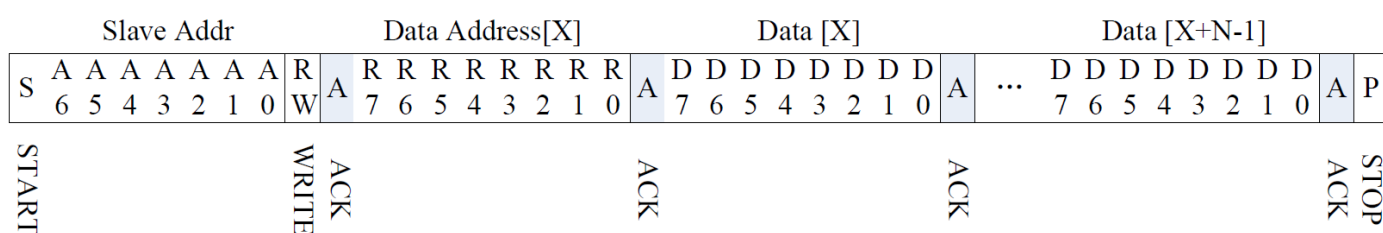

Figure 8. Set Data Address

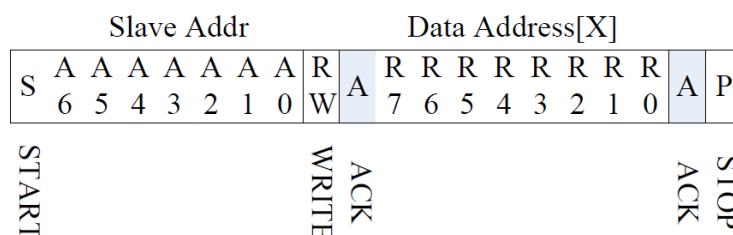
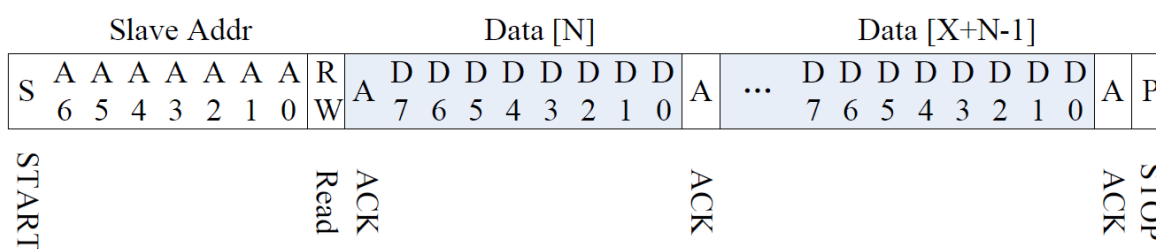
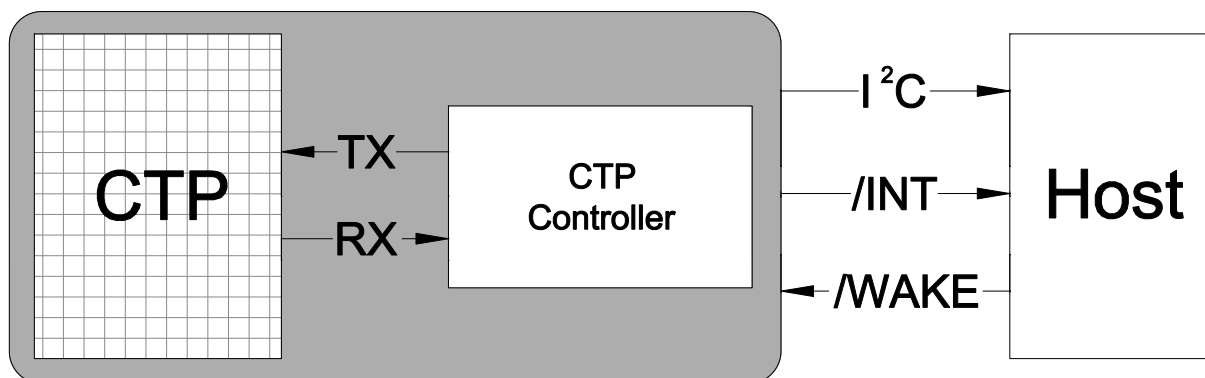

Figure 9. Read X bytes from I2C Slave



9.6 Communication of the I²C interface with Host

Figure 10. Communication of the I²C interface with Host



9.7 Touch data read protocol

ADDRESS	NAME	BIT 7	BIT 6	BIT 5	BIT 4	BIT 3	BIT 2	BIT 1	BIT 0	HOST ACCESS	
00h	DEVIDE_MODE	Device Mode[2:0]									RW
01h	GEST_ID	Gesture ID[7:0]									R
02h	TD_STATUS					Number of touch points[3:0]				R	
03h	TOUCH1_XH	1 st Event Flag				1 st Touch X Position[11:8]				R	
04h	TOUCH1_XL	1 st Touch X Position[7:0]								R	
05h	TOUCH1_YH	1 st Touch ID[3:0]					1 st Touch X Position[11:8]			R	
06h	TOUCH1_YL	1 st Touch Y Position[7:0]								R	
07h										R	
08h										R	
09h	TOUCH2_XH	2 nd Event Flag				2 nd Touch X Position[11:8]				R	
0Ah	TOUCH2_XL	2 nd Touch X Position[7:0]								R	
0Bh	TOUCH2_YH	2 nd Touch ID[3:0]					2 nd Touch X Position[11:8]			R	
0Ch	TOUCH2_YL	2 nd Touch Y Position[7:0]								R	
0Dh										R	
0Eh										R	
0Fh	TOUCH3_XH	3 rd Event Flag				3 rd Touch X Position[11:8]				R	
10h	TOUCH3_XL	3 rd Touch X Position[7:0]								R	
11h	TOUCH3_YH	3 rd Touch ID[3:0]					3 rd Touch X Position[11:8]			R	
12h	TOUCH3_YL	3 rd Touch Y Position[7:0]								R	
13h										R	
14h										R	
15h	TOUCH4_XH	4 th Event Flag				4 th Touch X Position[11:8]				R	
16h	TOUCH4_XL	4 th Touch X Position[7:0]								R	
17h	TOUCH4_YH	4 th Touch ID[3:0]					4 th Touch X Position[11:8]			R	
18h	TOUCH4_YL	4 th Touch Y Position[7:0]								R	
19h										R	
1Ah										R	
1Bh	TOUCH5_XH	5 th Event Flag				5 th Touch X Position[11:8]				R	
1Ch	TOUCH5_XL	5 th Touch X Position[7:0]								R	
1Dh	TOUCH5_YH	5 th Touch ID[3:0]					5 th Touch X Position[11:8]			R	
1Eh	TOUCH5_YL	5 th Touch Y Position[7:0]								R	

9.8 Data description.

DEVICE_MODE

This register is the device mode register, configure it to determine the current mode of the chip.

ADDRESS	BIT ADDRESS	REGISTER NAME	DESCRIPTION
00h	6:4	Device Mode [2:0]	000b Work Mode 100b Factory Mode – Read Raw Data

GEST_ID

This register describes the gesture of a valid touch.

ADDRESS	BIT ADDRESS	REGISTER NAME	DESCRIPTION
01h	7:0	Gesture ID [7:0]	Gesture ID 0x10 Move Up 0x14 Move Down 0x18 Move Right 0x48 Zoom In 0x49 Zoom Out 0x00 No Gesture

TD_STATUS

This register is the Touch Data status register.

ADDRESS	BIT ADDRESS	REGISTER NAME	DESCRIPTION
02h	3:0	Number of Touch Points [2:0]	How Many Points Detected 1-5 is Valid
	7:4		

TOUCHn_XH(n:1-10)

This register describes MSB of the X coordinate of the nth touch point and the corresponding event flag.

ADDRESS	BIT ADDRESS	REGISTER NAME	DESCRIPTION
03h ~ 39h	7:6	Event Flag	00b: Put Down 01b: Put Up 10b: Contact 11b: Reserved
	5:4		Reserved
	3:0	Touch X Position [11:8]	MSB of Touch X Position in Pixels

TOUCHn_XL(n:1-10)

This register describes LSB of the X coordinate of the nth touch point.

ADDRESS	BIT ADDRESS	REGISTER NAME	DESCRIPTION
04h ~ 3Ah	7:0	Touch X Position [7:0]	LSB of the Touch X Position in Pixels

TOUCHn_YH(n:1-10)

This register describes MSB of the Y coordinate of the nth touch point and corresponding touch ID.

ADDRESS	BIT ADDRESS	REGISTER NAME	DESCRIPTION
05h ~ 3Bh	7:4	Touch ID[3:0]	Touch ID of Touch Point
	3:0	Touch X Position [11:8]	MSB of Touch Y Position in Pixels

TOUCHn_YL(n:1-10)

This register describes LSB of the Y coordinate of the nth touch point.

ADDRESS	BIT ADDRESS	REGISTER NAME	DESCRIPTION
05h ~ 3Bh	7:0	Touch X Position [7:0]	LSB of the Touch Y Position in Pixels

9.9 Interrupt Trigger Mode

Figure 11. Interrupt trigger mode timing

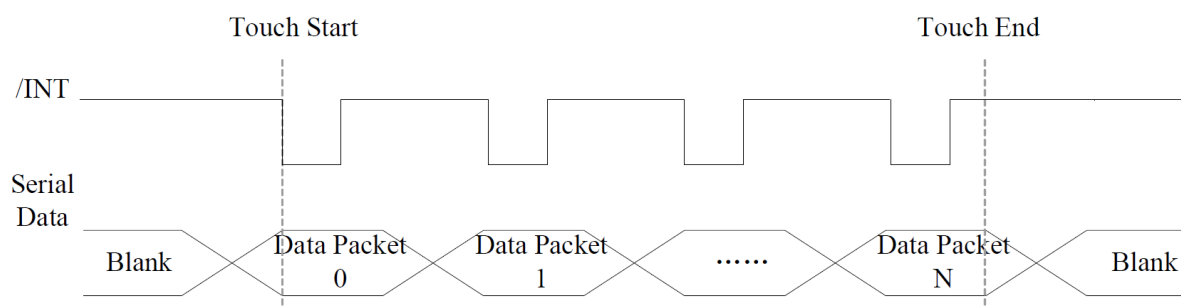

10 ORDERING INFORMATION

Three options of rear side adhesive tape are available: double side adhesive tape 0.2 mm with 3M 467MP glue, foam double side adhesive tape 0.5 mm with 3M 467MP glue or without any tape. There are also two versions of glass color: black and white.

Rear side adhesive tape options:

		
Double side adhesive tape with 3M 467MP glue (total thickness 0.2mm)	Foam double side adhesive tape with 3M 467MP glue (total thickness 0.5mm)	Without tape

Cover glass color options:

	
BLACK	WHITE

Product options:

PN	DESCRIPTION
RVT70UQSNWC00	<ul style="list-style-type: none"> • Double side adhesive tape with 3M 467MP glue (total thickness 0.2mm) • Cover glass color- black
RVT70UQSNWC01	<ul style="list-style-type: none"> • Foam double side adhesive tape with 3M 467MP glue (total thickness 0.5mm) • Cover glass - black
RVT70UQSNWC02	<ul style="list-style-type: none"> • Without tape • Cover glass color- black
RVT70UQSNWC03	<ul style="list-style-type: none"> • Double side adhesive tape with 3M 467MP glue (total thickness 0.2mm) • Cover glass color- white
RVT70UQSNWC04	<ul style="list-style-type: none"> • Foam double side adhesive tape with 3M 467MP glue (total thickness 0.5mm) • Cover glass color- white
RVT70UQSNWC05	<ul style="list-style-type: none"> • Without tape • Cover glass color- white

11 CUSTOMIZATION LEVEL

Beside standard product (**BASIC LEVEL**), there are two levels of product customization available:

1. **ADVANCED LEVEL**
2. **PROFESSIONAL LEVEL**

Basic level - standard version of product with black or white cover glass color.

Advanced level- product with modified cover glass color, company logo or with special transparent spots for diodes.



Professional level- product with changed panel parameters including glass dimension and shapes.



For more information, go to <http://riverdi.com/uxtouch/>

12 INSPECTION

Standard acceptance/rejection criteria for TFT module.

12.1 Inspection condition

Ambient conditions:

- Temperature: $25\pm^{\circ}\text{C}$
- Humidity: $(60\pm 10)\% \text{RH}$
- Illumination: Single fluorescent lamp non-directive (300 to 700 lux)

Viewing distance:

$35\pm 5\text{cm}$ between inspector bare eye and LCD.

Viewing Angle:

U/D: $45^{\circ}/45^{\circ}$, L/R $45^{\circ}/45^{\circ}$

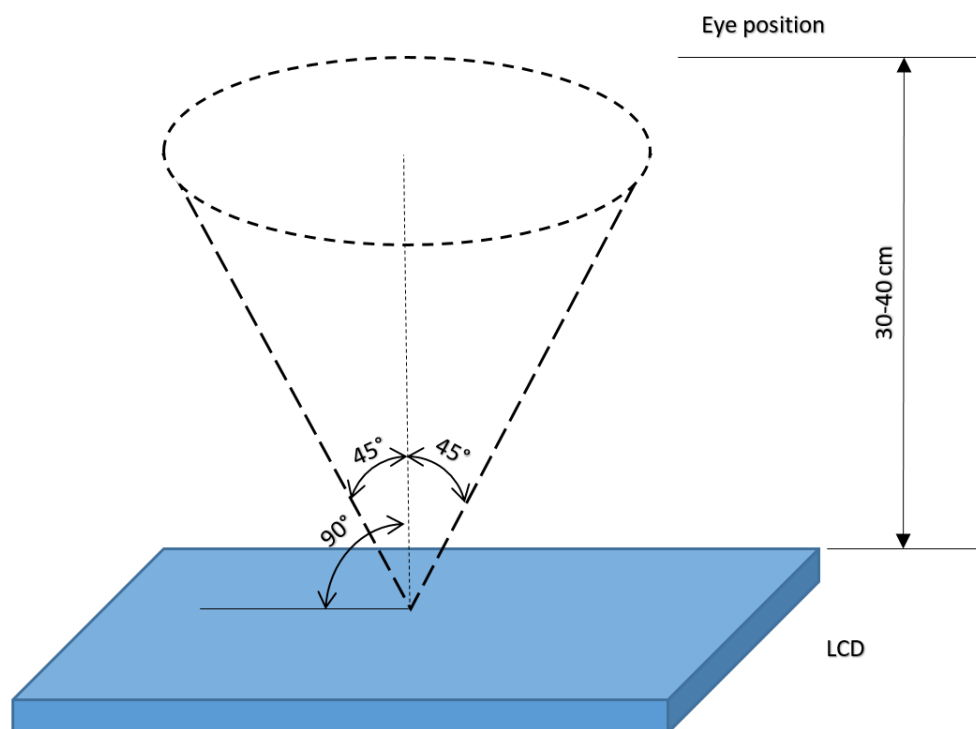

12.2 Inspection standard

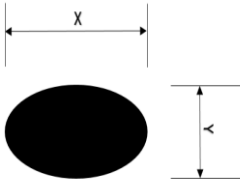
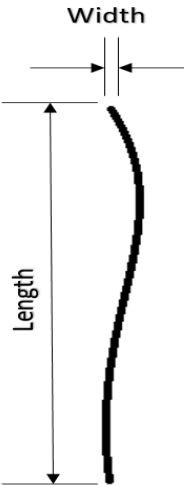
Item	Criterion																																		
<p>Black spots, white spots, light leakage, Foreign Particle (round Type)</p>	<div style="display: flex; align-items: center; justify-content: center;">  <table border="1" style="margin-left: 20px;"> <thead> <tr> <th colspan="2">Size < 5"</th> </tr> <tr> <th>Average Diameter</th> <th>Qualified Qty</th> </tr> </thead> <tbody> <tr> <td>D < 0.2 mm</td> <td>Ignored</td> </tr> <tr> <td>0.2 mm < D < 0.3 mm</td> <td>3</td> </tr> <tr> <td>0.3 mm < D < 0.5 mm</td> <td>2</td> </tr> <tr> <td>0.5 mm < D</td> <td>0</td> </tr> </tbody> </table> </div> <div style="text-align: center; margin: 10px 0;"> $D = \frac{(x + y)}{2}$ </div> <p>*Spots density: 10 mm</p>	Size < 5"		Average Diameter	Qualified Qty	D < 0.2 mm	Ignored	0.2 mm < D < 0.3 mm	3	0.3 mm < D < 0.5 mm	2	0.5 mm < D	0																						
Size < 5"																																			
Average Diameter	Qualified Qty																																		
D < 0.2 mm	Ignored																																		
0.2 mm < D < 0.3 mm	3																																		
0.3 mm < D < 0.5 mm	2																																		
0.5 mm < D	0																																		
<p>LCD black spots, white spots, light leakage (line Type)</p>	<div style="display: flex; align-items: center; justify-content: center;">  <table border="1" style="margin-left: 20px;"> <thead> <tr> <th colspan="3">Size < 5"</th> </tr> <tr> <th>Length</th> <th>Width</th> <th>Qualified Qty</th> </tr> </thead> <tbody> <tr> <td>-</td> <td>W < 0.02</td> <td>Ignored</td> </tr> <tr> <td>L < 3.0</td> <td>0.02 < W < 0.05</td> <td rowspan="2">2</td> </tr> <tr> <td>L < 2.5</td> <td>0.05 < W < 0.08</td> </tr> <tr> <td>-</td> <td>0.08 < W</td> <td>0</td> </tr> </tbody> </table> </div> <div style="text-align: center; margin: 10px 0;"> <table border="1"> <thead> <tr> <th colspan="3">Size >= 5"</th> </tr> <tr> <th>Length</th> <th>Width</th> <th>Qualified Qty</th> </tr> </thead> <tbody> <tr> <td>-</td> <td>W < 0.02</td> <td>Ignored</td> </tr> <tr> <td>L < 3.0</td> <td>0.02 < W < 0.05</td> <td rowspan="2">4</td> </tr> <tr> <td>L < 2.5</td> <td>0.05 < W < 0.08</td> </tr> <tr> <td>-</td> <td>0.08 < W</td> <td>0</td> </tr> </tbody> </table> </div> <p>*Spots density: 10 mm</p>	Size < 5"			Length	Width	Qualified Qty	-	W < 0.02	Ignored	L < 3.0	0.02 < W < 0.05	2	L < 2.5	0.05 < W < 0.08	-	0.08 < W	0	Size >= 5"			Length	Width	Qualified Qty	-	W < 0.02	Ignored	L < 3.0	0.02 < W < 0.05	4	L < 2.5	0.05 < W < 0.08	-	0.08 < W	0
Size < 5"																																			
Length	Width	Qualified Qty																																	
-	W < 0.02	Ignored																																	
L < 3.0	0.02 < W < 0.05	2																																	
L < 2.5	0.05 < W < 0.08																																		
-	0.08 < W	0																																	
Size >= 5"																																			
Length	Width	Qualified Qty																																	
-	W < 0.02	Ignored																																	
L < 3.0	0.02 < W < 0.05	4																																	
L < 2.5	0.05 < W < 0.08																																		
-	0.08 < W	0																																	

Item	Criterion	
Clear spots	Size < 5"	
	Average Diameter	Qualified Qty
	D < 0.2 mm	Ignored
	0.2 mm < D < 0.3 mm	3
	0.3 mm < D < 0.5 mm	2
	0.5 mm < D	0
	Size >= 5"	
	Average Diameter	Qualified Qty
	D<0.2 mm	Ignored
	0.2 mm < D < 0.3 mm	4
	0.3 mm < D < 0.5 mm	2
	0.5 mm < D	0
	*Spots density: 10 mm	
	Polarizer bubbles	Size < 5"
Average Diameter		Qualified Qty
D < 0.2 mm		Ignored
0.2 mm < D < 0.5 mm		3
0.5 mm < D < 1 mm		2
1 mm < D		0
Total Q'ty		3
Size >= 5"		
Average Diameter		Qualified Qty
D<0.25 mm		Ignored
0.25 mm < D < 0.5 mm		3
0.5 mm < D		0
Electrical Dot Defect		Size < 5"
		item
	Black do defect	4
	Bright dot defect	2
	Total Dot	5
	Size >= 5"	
	item	Qualified Qty
	Black do defect	5
	Bright dot defect	2
	Total Dot	5

Item	Criterion		
Touch panel spot	Size < 5"		
	Average Diameter	Qualified Qty	
	D < 0.2 mm	Ignored	
	0.2 mm < D < 0.4 mm	5	
	0.4 mm < D < 0.5 mm	2	
	0.5 mm < D	0	
	Size >= 5"		
	Average Diameter	Qualified Qty	
	D < 0.25 mm	Ignored	
	0.25 mm < D < 0.5 mm	4	
0.5 mm < D	0		
Touch panel White Line Scratch	Size < 5"		
	Length	Width	Qualified Qty
	-	W < 0.02	Ignored
	L < 3.0	0.02 < W < 0.05	2
	L < 2.5	0.05 < W < 0.08	
	-	0.08 < W	0
	Size >= 5"		
	Length	Width	Qualified Qty
	-	W < 0.03	Ignored
	L < 5.0	0.03 < W < 0.05	2
-	0.05 < W	0	

13 RELIABILITY TEST

NO.	TEST ITEM	TEST CONDITION
1	High Temperature Storage	80±2°C/240hours
2	Low Temperature Storage	-30±2°C/240hours
3	High Temperature Operating	70±2°C/240hours
4	Low Temperature Operating	-20±2°C/240hours
5	Temperature Cycle	-30±2°C~25~80±2°C × 20 cycles (30min.) (5min.) (30min.)
6	Damp Proof Test	60°C ±5°C × 90%RH/240hours
7	Vibration Test	Frequency 10Hz~55Hz Amplitude of vibration : 1.5mm Sweep: 10Hz~55Hz~10Hz X, Y, Z 2 hours for each direction.
8	Package Vibration Test	Random vibration :0.15G*G/HZ from 5-200HZ,-6dB/Octave from 200-500HZ of each direction of X.Y. Z (6 hours for total)
9	Package Drop Test	Height:60 cm 1 corner,3 edges,6 surfaces
10	ESD Test	± 2KV, Human body mode,100pF/1500Ω
11	Mechanical Shock	100G 6ms, X, Y, Z 3 times for each direction

LEGAL INFORMATION

Riverdi makes no warranty, either expressed or implied with respect to any product, and specifically disclaims all other warranties, including, without limitation, warranties for merchantability, non-infringement and fitness for any particular purpose. Information about device are the property of Riverdi and may be the subject of patents pending or granted. It is not allowed to copy or disclosed this document without prior written permission.

Riverdi endeavors to ensure that the all contained information in this document are correct but does not accept liability for any error or omission. Riverdi products are in developing process and published information may be not up to date. Riverdi reserves the right to update and makes changes to Specifications or written material without prior notice at any time. It is important to check the current position with Riverdi.

Images and graphics used in this document are only for illustrative the purpose. All images and graphics are possible to be displayed on the range products of Riverdi, however the quality may vary. Riverdi is no liable to the buyer or to any third part for any indirect, incidental, special, consequential, punitive or exemplary damages (including without limitation lost profits, lost savings, or loss of business opportunity) relating to any product, service provided or to be provided by Riverdi, or the use or inability to use the same, even if Riverdi has been advised of the possibility of such damages.

Riverdi products are not fault tolerant nor designed, manufactured or intended for use or resale as on line control equipment in hazardous environments requiring fail – safe performance, such as in the operation of nuclear facilities, aircraft navigation or communication systems, air traffic control, direct life support machines or weapons systems in which the failure of the product could lead directly to death, personal injury or severe physical or environmental damage ('High Risk Activities'). Riverdi and its suppliers specifically disclaim any expressed or implied warranty of fitness for High Risk Activities. Using Riverdi products and devices in 'High Risk Activities' and in any other application is entirely at the buyer's risk, and the buyer agrees to defend, indemnify and hold harmless Riverdi from any and all damages, claims or expenses resulting from such use. No licenses are conveyed, implicitly or otherwise, under any Riverdi intellectual property rights.

