

Features

- N-Channel
40V/40A,
 $R_{DS(ON)} = 12m\Omega (Typ.) @ V_{GS}=10V$
 $R_{DS(ON)} = 17m\Omega (Typ.) @ V_{GS}=4.5V$
- P-Channel
-40V/-40A,
 $R_{DS(ON)} = 21m\Omega (Typ.) @ V_{GS}=-10V$
 $R_{DS(ON)} = 30m\Omega (Typ.) @ V_{GS}=-4.5V$
- Fast Switching Speed
 - ESD Protected
- Low gate Charge
- Lead Free and Green Devices Available (RoHS Compliant)

Applications

- Load Switch

Pin Description

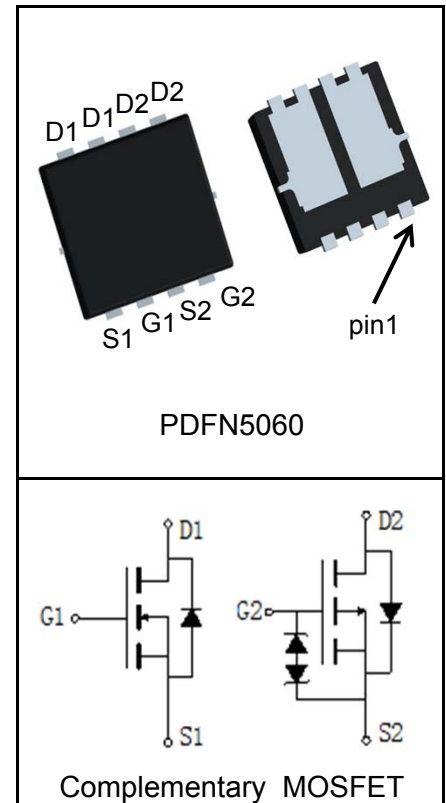

Absolute Maximum Ratings

Symbol	Parameter		N-Channel	P-Channel	Unit
Common Ratings ($T_A=25^\circ C$ Unless Otherwise Noted)					
V_{DSS}	Drain-Source Voltage		40	-40	V
V_{GSS}	Gate-Source Voltage		± 20	± 20	
T_J	Maximum Junction Temperature		150	150	$^\circ C$
T_{STG}	Storage Temperature Range		-55 to 150	-55 to 150	$^\circ C$
I_S	Diode Continuous Forward Current	$T_A=25^\circ C$	20	-20	A
Mounted on Large Heat Sink					
$I_{DP}^{①}$	300 μs Pulse Drain Current Tested	$T_A=25^\circ C$	160	-160	A
$I_D^{②}$	Continuous Drain Current($V_{GS}=\pm 10V$)	$T_A=25^\circ C$	40	-40	A
		$T_A=100^\circ C$	25	-25	
P_D	Maximum Power Dissipation	$T_A=25^\circ C$	42	36	W
		$T_A=100^\circ C$	17	14	
$R_{\theta JC}$	Thermal Resistance-Junction to Case		3	3.5	$^\circ C/W$
$R_{\theta JA}^{③}$	Thermal Resistance-Junction to Ambient		50	50	$^\circ C/W$
Drain-Source Avalanche Ratings					
$E_{AS}^{④}$	Avalanche Energy, Single Pulsed		42	42	mJ

Electrical Characteristics ($T_A=25^\circ\text{C}$ Unless Otherwise Noted)

Symbol	Parameter	Test Condition	RU40C40M			Unit
			Min.	Typ.	Max.	
Static Characteristics						
BV_{DSS}	Drain-Source Breakdown Voltage	$V_{GS}=0V, I_{DS}=250\mu A$	N	40		V
		$V_{GS}=0V, I_{DS}=-250\mu A$	P	-40		
I_{DSS}	Zero Gate Voltage Drain Current	$V_{DS}=40V, V_{GS}=0V$	N		1	μA
		$T_J=125^\circ C$			30	
		$V_{DS}=-40V, V_{GS}=0V$	P		-1	
		$T_J=125^\circ C$			-30	
$V_{GS(th)}$	Gate Threshold Voltage	$V_{DS}=V_{GS}, I_{DS}=250\mu A$	N	1	2.5	V
		$V_{DS}=V_{GS}, I_{DS}=-250\mu A$	P	-1	-2.5	
I_{GSS}	Gate Leakage Current	$V_{GS}=\pm 20V, V_{DS}=0V$	N		± 1	μA
		$V_{GS}=\pm 20V, V_{DS}=0V$	P		± 10	
$R_{DS(ON)}^{(5)}$	Drain-Source On-state Resistance	$V_{GS}=10V, I_{DS}=20A$	N		12	m Ω
		$V_{GS}=-10V, I_{DS}=-20A$	P		21	
		$V_{GS}=4.5V, I_{DS}=16A$	N		17	
		$V_{GS}=-4.5V, I_{DS}=-16A$	P		30	
Diode Characteristics						
$V_{SD}^{(5)}$	Diode Forward Voltage	$I_{SD}=20A, V_{GS}=0V$	N		1.2	V
		$I_{SD}=-20A, V_{GS}=0V$	P		-1.3	
t_{rr}	Reverse Recovery Time	N-Channel $I_{SD}=20A, di_{SD}/dt=100A/\mu s$	N		15	ns
			P		36	
Q_{rr}	Reverse Recovery Charge	P-Channel $I_{SD}=-20A, di_{SD}/dt=100A/\mu s$	N		31	nC
			P		26	
Dynamic Characteristics ⁽⁶⁾						
R_G	Gate Resistance	$V_{GS}=0V, V_{DS}=0V, F=1MHz$	N		1.2	Ω
			P		1.5	
C_{iss}	Input Capacitance	N-Channel $V_{GS}=0V, V_{DS}=20V,$ Frequency=1.0MHz	N		880	pF
			P		1900	
C_{oss}	Output Capacitance	P-Channel $V_{GS}=0V, V_{DS}=-20V,$ Frequency=1.0MHz	N		170	
			P		245	
C_{rss}	Reverse Transfer Capacitance	N-Channel $V_{GS}=0V, V_{DS}=-20V,$ Frequency=1.0MHz	N		70	
			P		135	

Electrical Characteristics ($T_A=25^{\circ}\text{C}$ Unless Otherwise Noted)

Symbol	Parameter	Test Condition	RU40C40M			Unit
			Min.	Typ.	Max.	
Dynamic Characteristics ^⑥						
$t_{d(ON)}$	Turn-on Delay Time	N-Channel $V_{DD}=20\text{V}, I_{DS}=20\text{A},$ $V_{GEN}=10\text{V}, R_G=4.7\Omega$ P-Channel $V_{DD}=-20\text{V}, I_{DS}=-20\text{A},$ $V_{GEN}=-10\text{V}, R_G=4.7\Omega$	N		6	ns
			P		15	
t_r	Turn-on Rise Time		N		10	
			P		43	
$t_{d(OFF)}$	Turn-off Delay Time		N		24	
			P		24	
t_f	Turn-off Fall Time		N		5	
			P		14	
Gate Charge Characteristics ^⑥						
Q_g	Total Gate Charge	N-Channel $V_{DS}=32\text{V}, V_{GS}=10\text{V},$ $I_{DS}=20\text{A}$ P-Channel $V_{DS}=-32\text{V}, V_{GS}=-10\text{V},$ $I_{DS}=-20\text{A}$	N		18	nC
			P		42	
Q_{gs}	Gate-Source Charge		N		6	
			P		9	
Q_{gd}	Gate-Drain Charge		N		5	
			P		14	

- Notes:**
- ① Pulse width limited by safe operating area.
 - ② Calculated continuous current based on maximum allowable junction temperature.
 - ③ When mounted on 1 inch square copper board, $t \leq 10\text{sec}$.
 - ④ Limited by T_{Jmax} , $I_{AS} = 13\text{A}$, $V_{DD} = 24\text{V}$, $R_G = 50\Omega$, Starting $T_J = 25^{\circ}\text{C}$.
 - ⑤ Pulse test ; Pulse width 300s, duty cycle 2%.
 - ⑥ Guaranteed by design, not subject to production testing.

Ordering and Marking Information

Device	Marking	Package	Packaging	Quantity	Reel Size	Tape width
RU40C40M	RU40C40M	PDFN5060	Tape&Reel	3000	13"	12mm

Typical Characteristics(N-Channel)

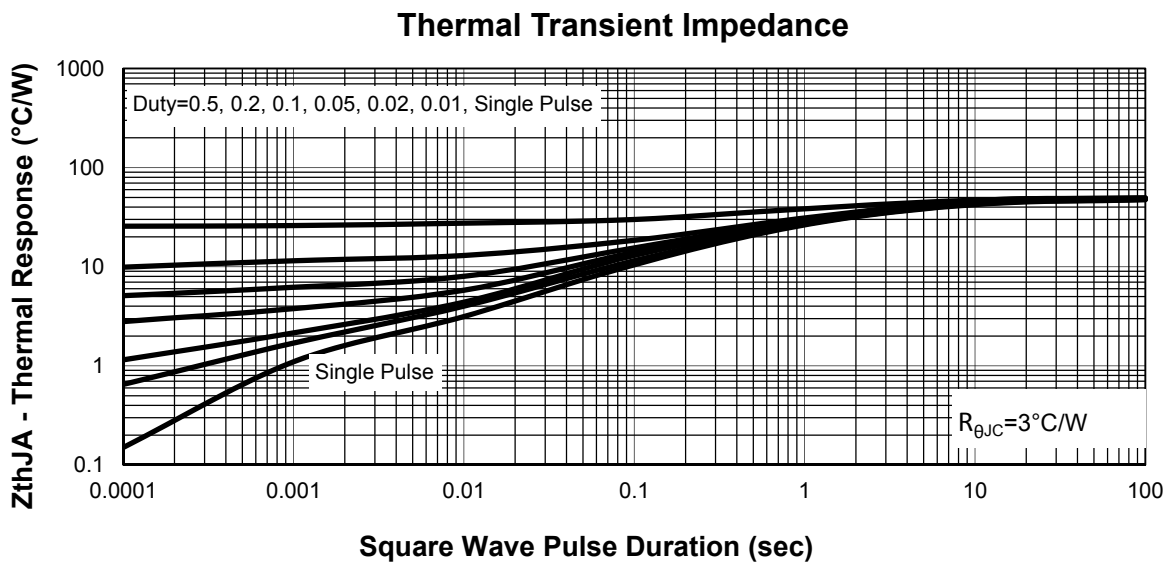
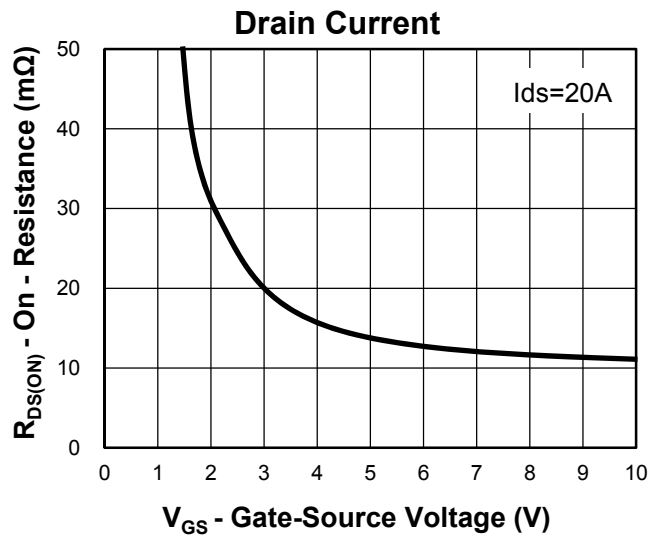
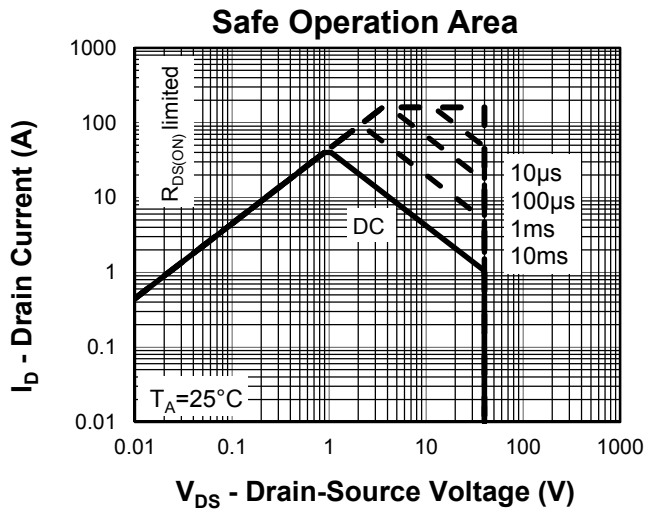
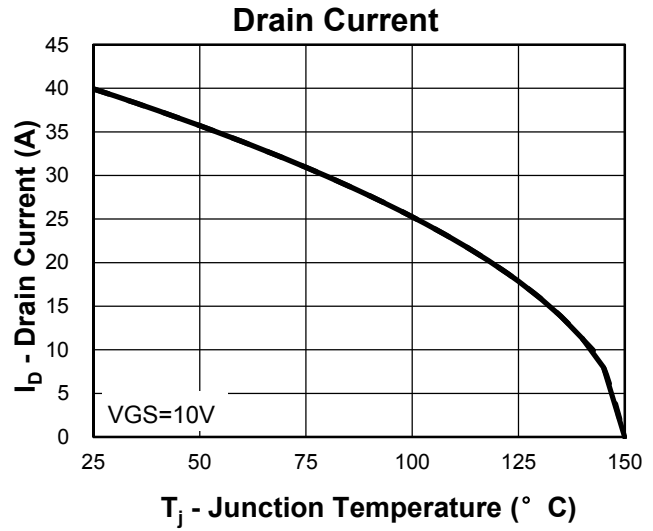
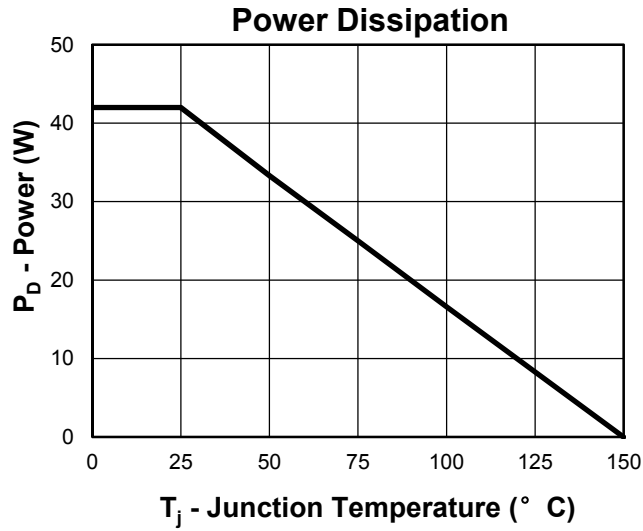

Typical Characteristics(N-Channel)

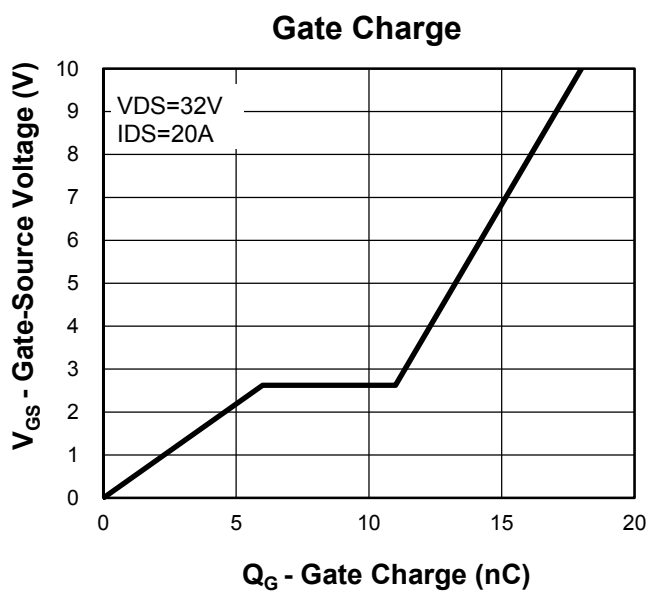
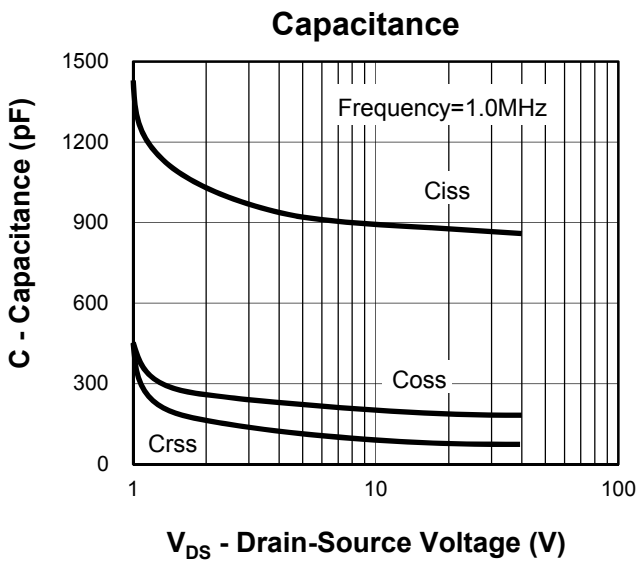
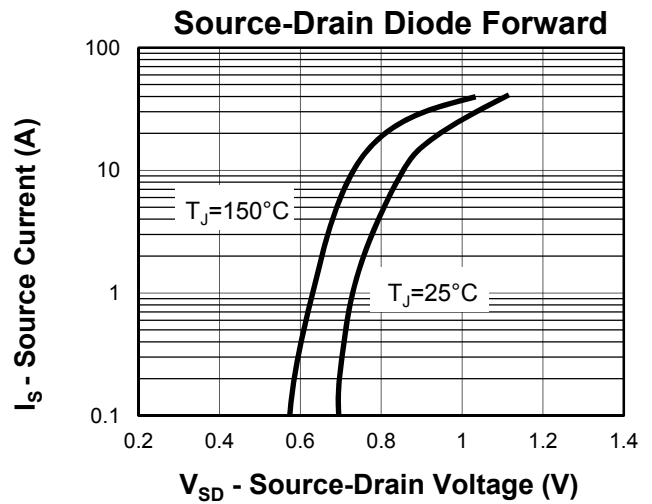
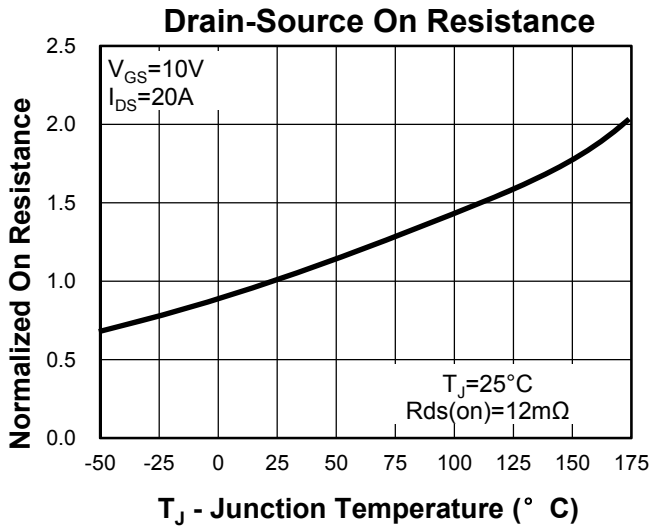
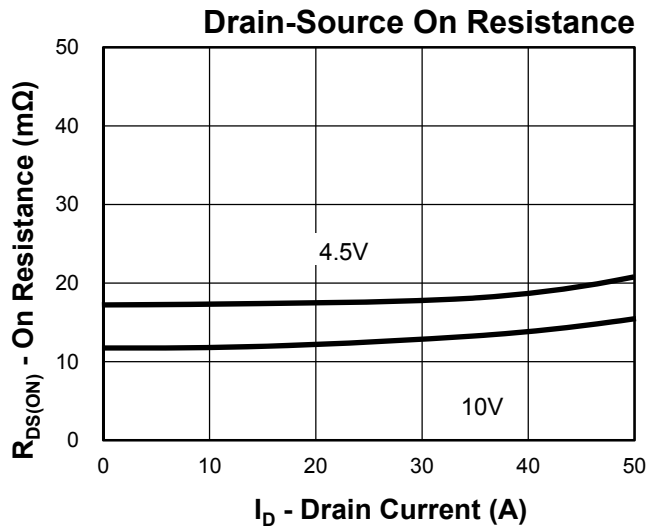
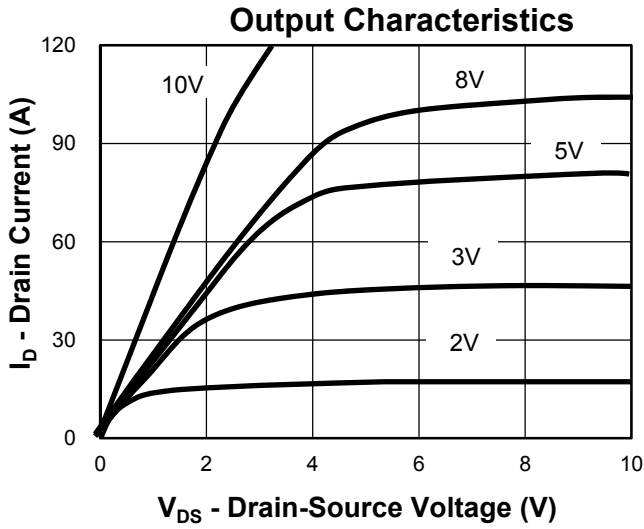

Typical Characteristics(P-Channel)

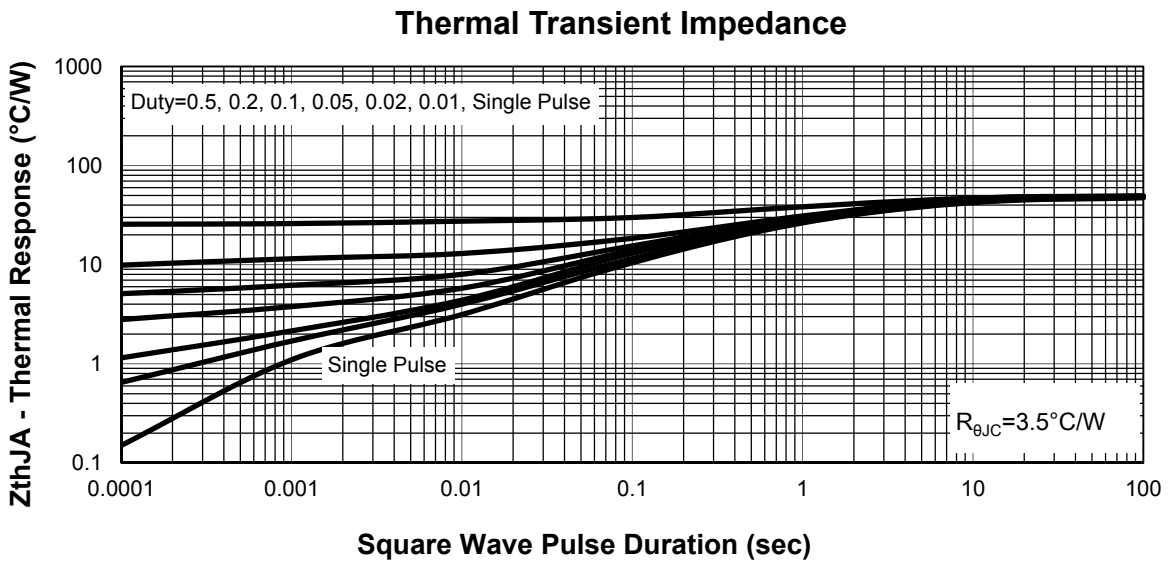
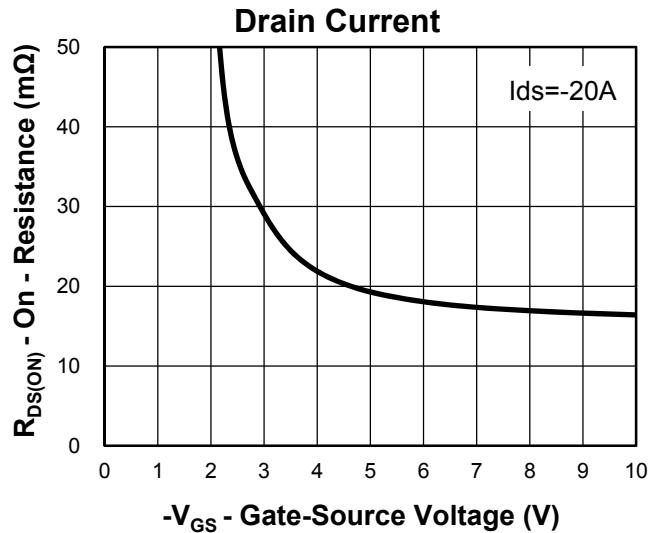
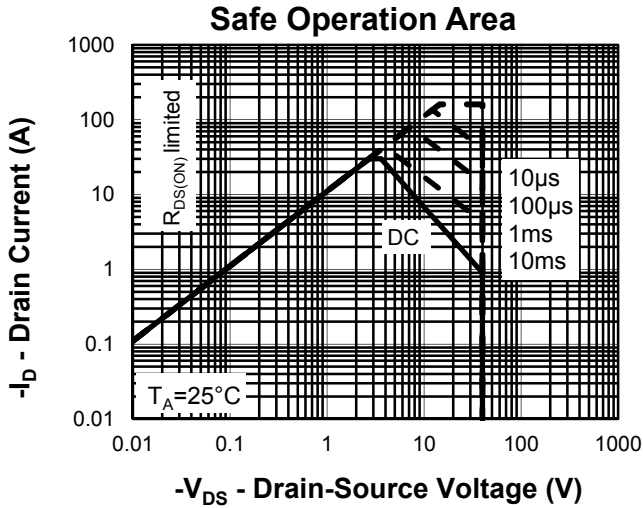
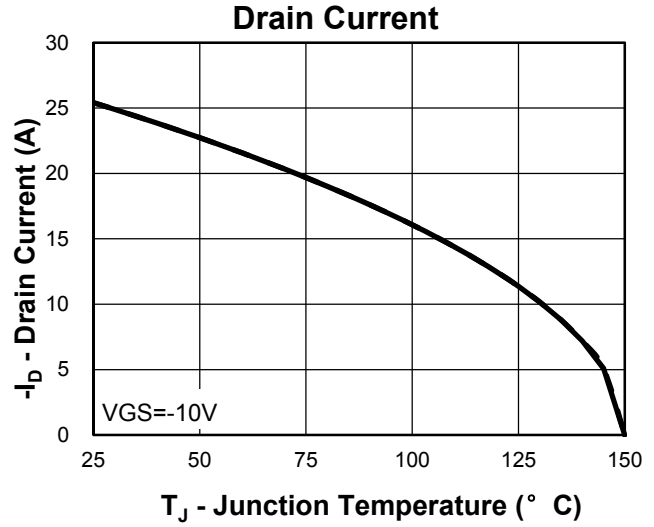
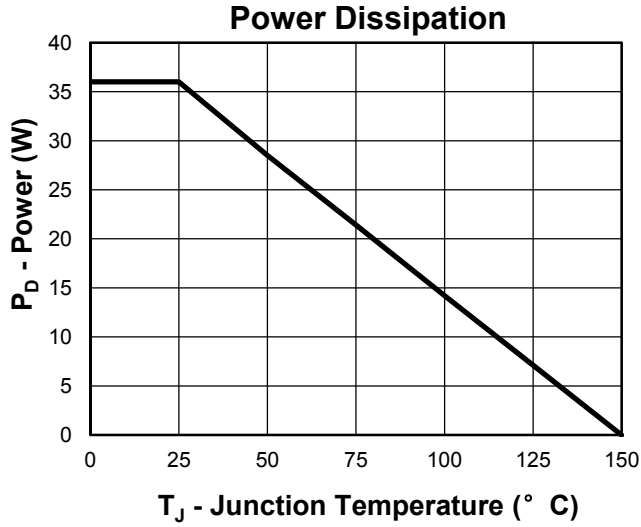

Typical Characteristics(P-Channel)

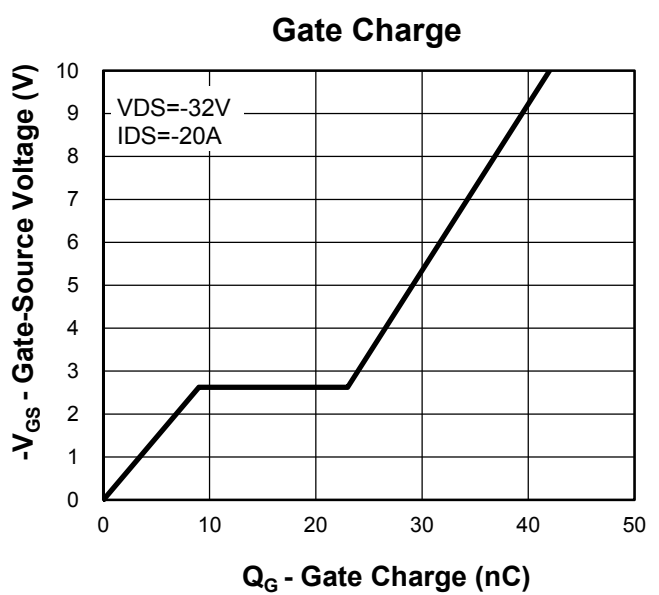
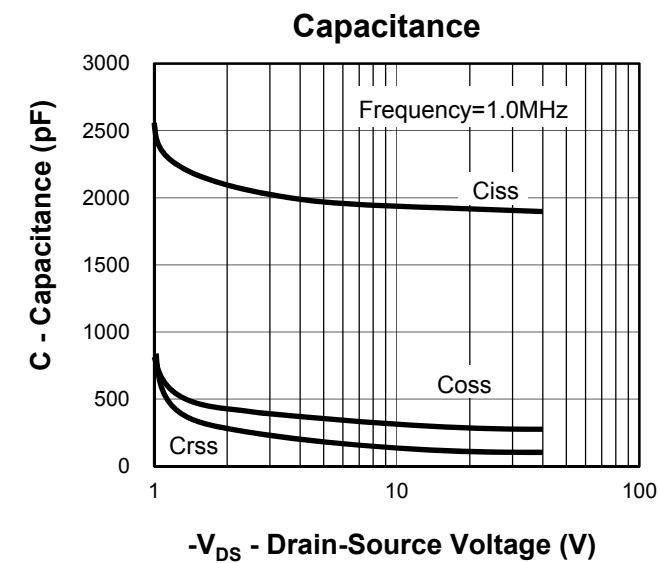
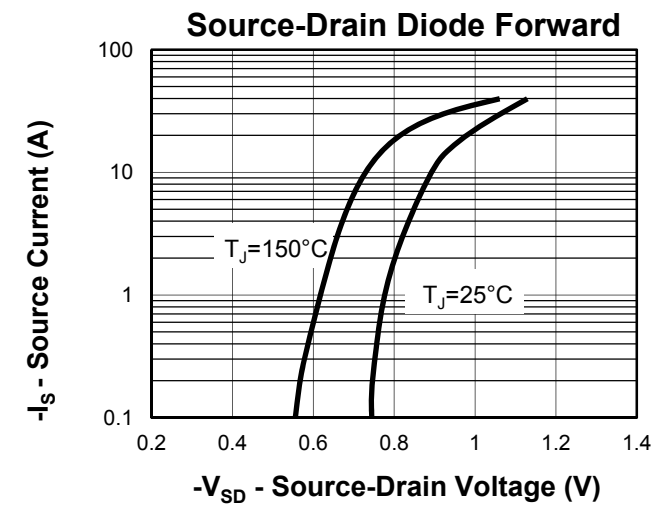
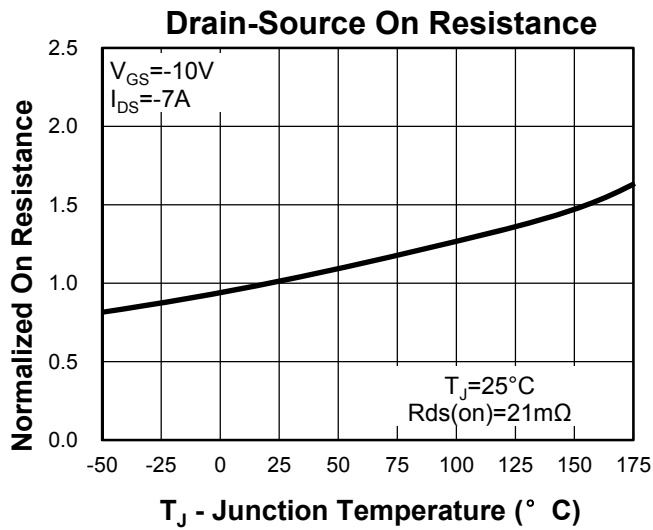
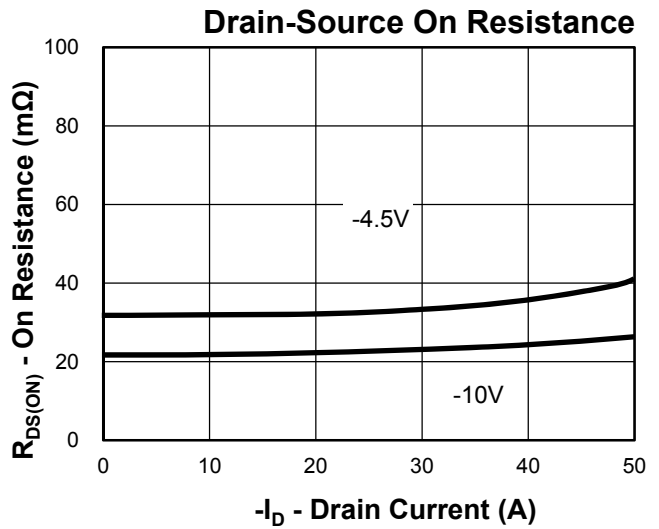
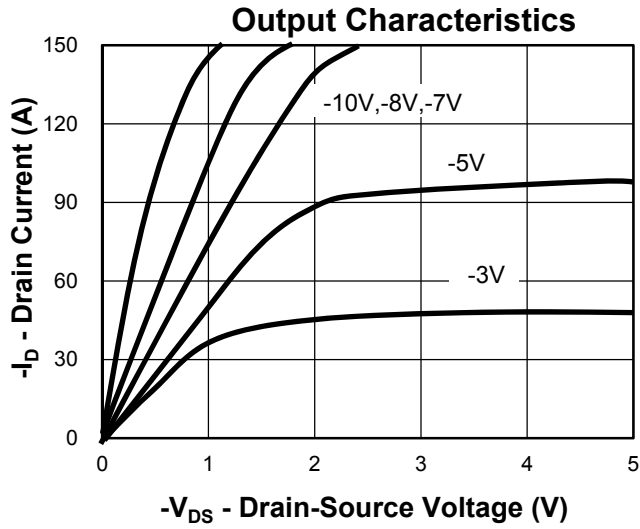

Avalanche Test Circuit and Waveforms

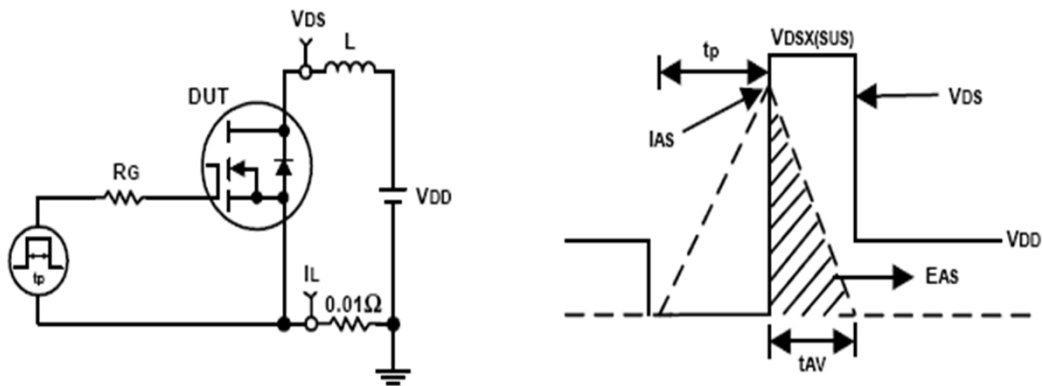

Switching Time Test Circuit and Waveforms

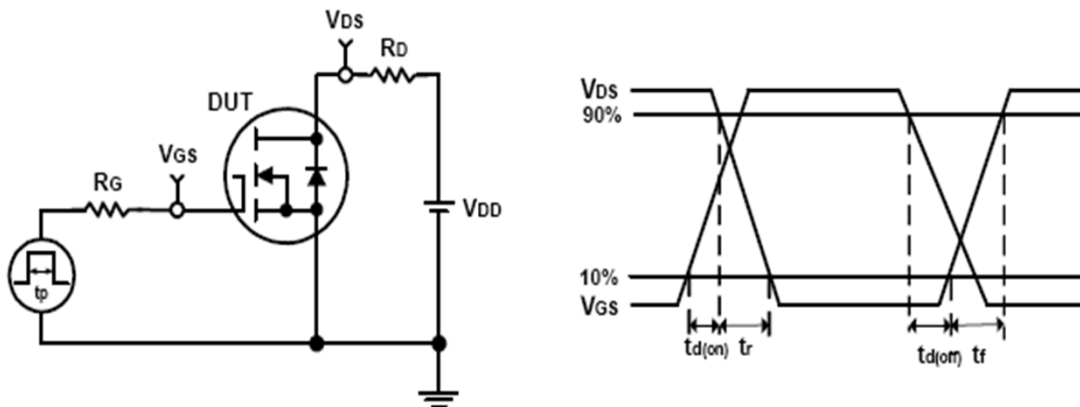

Package Information

PDFN5060

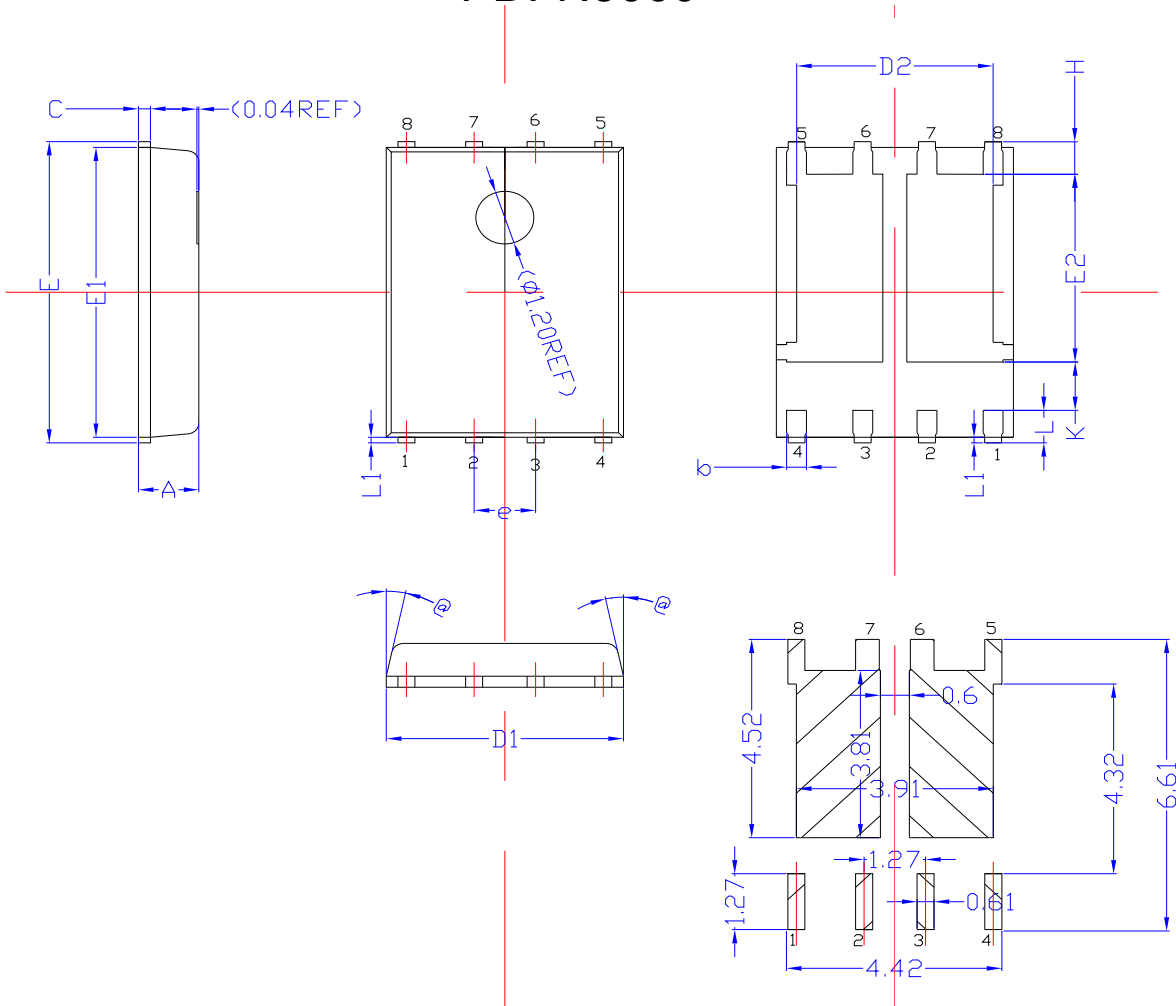

NOTE:

- 1: ALL UNITS ARE IN MILLIMETER.
- 2: EJECTOR PIN MARK POSITION MAY VARY FROM DIFFERENT MOLD.
- 3: ALL DIMENSIONS REFER TO JEDEC.DO NOT INCLUDE MOLD FLASH OR PROTRUSIONS.

SYMBOL	MM			INCH			SYMBOL	MM			INCH		
	MIN	NOM	MAX	MIN	NOM	MAX		MIN	NOM	MAX	MIN	NOM	MAX
A	0.90	1.00	1.10	0.035	0.039	0.043	E1	5.70	5.75	5.80	0.224	0.226	0.228
b	0.33	0.41	0.51	0.013	0.016	0.020	E2	3.38	3.58	3.78	0.133	0.141	0.149
c	0.20	0.25	0.30	0.008	0.010	0.012	e	1.27BSC			0.05BSC		
D1	4.80	4.90	5.00	0.189	0.193	0.197	H	0.41	0.51	0.61	0.016	0.020	0.024
D2	3.61	3.81	3.96	0.142	0.150	0.156	L	0.51	0.61	0.71	0.020	0.024	0.028
L1	0.06	0.13	0.20	0.002	0.005	0.008							
E	5.90	6.00	6.10	0.232	0.236	0.240	@	0°	*	12°	*	10°	12°
K	1.10	*	*	0.043	*	*	M	0.50	*	*	0.020	*	*

Customer Service**Worldwide Sales and Service:**

Sales@ruichips.com

Technical Support:

Technical@ruichips.com

Investor Relations Contacts:

Investor@ruichips.com

Marcom Contact:

Marcom@ruichips.com

Editorial Contact:

Editorial@ruichips.com

HR Contact:

HR@ruichips.com

Legal Contact:

Legal@ruichips.com

Shen Zhen RUICHIPS Semiconductor CO., LTD

4th Floor, Block 8, Changyuan New Material Port, Keyuan Middle Road, Science & Industry Park,
Nanshan District, Shenzhen, CHINA

TEL: (86-755) 8311-5334

FAX: (86-755) 8311-4278

E-mail: Sales-SZ@ruichips.com