

GENERAL DESCRIPTION

The PT4102 is a step-up DC/DC converter designed for driving up to 8 white LEDs in series from a single cell Lithium Ion battery with constant current. Because it directly regulates output current, the PT4102 is ideal for driving light emitting diodes (LEDs) whose light intensity is proportional to the current passing through them, not the voltage across their terminals. A single external resistor sets LED current between 5mA and 20mA, which can then be easily adjusted using either a DC voltage or a pulse width modulated (PWM) signal. The PT4102 switches at 1.2MHz, allowing the uses of tiny external components. The output capacitor can be as small as 0.22uF. Its low 88/104mV feedback voltage reduces power loss and improves efficiency. The PT4102 is available in SOT-23-5 and SC-70 packages.

FEATURES

- Built-in 40V Power MOSFET
- Drives Up to 8 Series White LEDs from 3.6V
- Up to 87% Efficiency
- 1.2MHz Fixed Switching Frequency
- Low Feedback Voltage: 104mV for E-suffix, 88mV for S-suffix.
- PWM or DC Dimming
- Current Limit
- 0.22uF Output Capacitor
- Package: SOT-23-6 and SC-70

APPLICATIONS

- Cell Phones
- Handheld Computers and PDAs
- Digital Cameras
- Small LCD Displays

TYPICAL APPLICATIONS

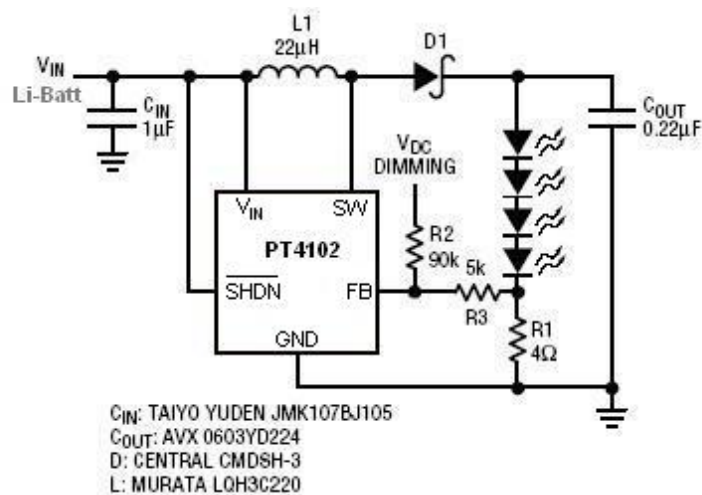

Figure 1. Li-Ion Driver for 4 White LEDs

ORDERING INFORMATION

PT4102CPPP

Package Type

23E: SOT-23-5

70F: SC70-6

Sub-type

E: Type E

S: Type S

PACKAGES



PIN DESCRIPTION

Pin No.		Pin Names	Description
SOT-23-6	SC70		
1	1	SW	Power Switch Output. Connect the inductor and the blocking Schottky diode to SW.
2	2, 5	GND	Ground
3	3	FB	Feedback input pin. The reference voltage at this pin is 88/104mV. Connect the cathode of the lowest LED to FB and a current sense resistor between FB and GND.
4	4	SHDN	Enable pin. A high input at this pin enables the device and a low input disables the devices. When not used, connect it to the input source for automatic startup.
5	6	V _{IN}	Input Supply Pin. Must be locally bypassed.

ABSOLUTE MAXIMUM RATINGS

SYMBOL	ITEMS	VALUE	UNIT
V _{IN}	Input Voltage	-0.3~6	V
V _{SW}	Voltage at SW Pin	-0.5~44	V
V _{IO}	All Other I/O Pins	GND-0.3 to VDD+0.3	V
P _{TR1}	Thermal Resistance, SOT-23-6		
	θ _{JA} θ _{JC}	220 110	°C/W
P _{TR2}	Thermal Resistance, QFN-8 (2mm x 2mm)		
	θ _{JA} θ _{JC}	80 16	°C/W
Top	Operating Temperature	-40 to 85	°C
T _{stg}	Storage Temperature	-55 to 150	
T _{solder}	Package Lead Soldering Temperature	260°C, 10s	

ELECTRICAL CHARACTERISTICS

$V_{IN}=V_{SHDN}=3V$, $T_{opt}=25^{\circ}C$ unless specified otherwise.

SYMBOL	ITEMS	CONDITIONS	Min.	Typ.	Max.	UNIT
V_{IN}	Input Voltage		2.5		6	V
Feedback						
V_{FB}	FB Pin Voltage, Type E	Driving 4xLED @15mA,	94	104	114	mV
	FB Pin Voltage, Type S	$I_{SW}=100mA$, Duty=66%	78	88	98	mV
Ibias	FB Pin Input Bias Current			0.05	0.1	μA
Operating Current						
Ioff	Operating Current(Shutdown)	$V_{SW-ON}=0V$		0.1	1	μA
Isby	Operating Current(Quiescent)	$V_{FB}=0.15V$		100		μA
Iin	Operating Current	4xLED		0.7	2.5	mA
Fsw	Switching Frequency	3xLED, 15mA	0.8	1.2	1.6	MHz
Dmax	Maximum Duty Cycle	$V_{FB}=0V$	85	90		%
Chip Enable						
V_{EN_H}	SHDN Minimum High Level		1.5			V
V_{EN_L}	SHDN Maximum Low Level				0.4	V
V_{HYS}	SHDN Hysteresis			90		mV
	SHDN Input Bias Current	$V_{SW-ON}=0V, 5V$			1	μA
Output Switch						
Ron	On-Resistor of Switch	$V_{SW-ON}=350mV, I_{SW}=250mA$		1.4		Ω
V_{SW}	SW drop-out volatge	$I_{SW}=250mA$		350		mV
I_{LIMIT}	SW Current Limit			270		mA
I_{LEAK}	SW Leakage	$V_{SW}=5V$		0.01	1	μA
	Thermal Shutdown			160		$^{\circ}C$

TESTING CIRCUIT

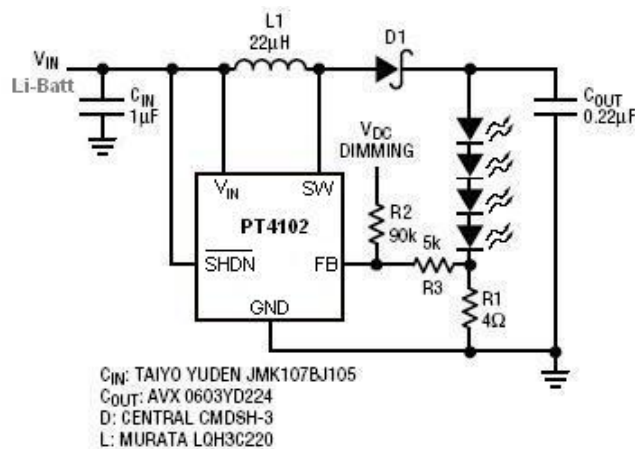

Figure 2. Testing Circuit

TYPICAL PERFORMANCE CHARACTERISTICS

1. Driving Capability

In Voltage(Vin)	I _{LED} =15mA	I _{LED} =20mA
2.5V	5	3
3.0V	5	4
3.6V	7	5
4.2V	8	6

2. Efficiency

Figure 3. Efficiency vs Vin and I_{LED}

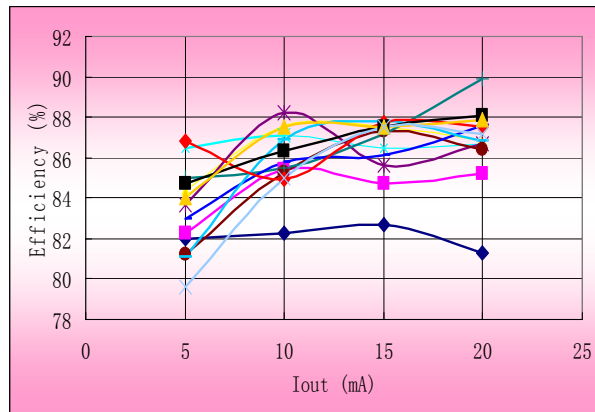

3. Quiescent Current vs VIN and Temperature

Figure 4. I_q vs. Temperature

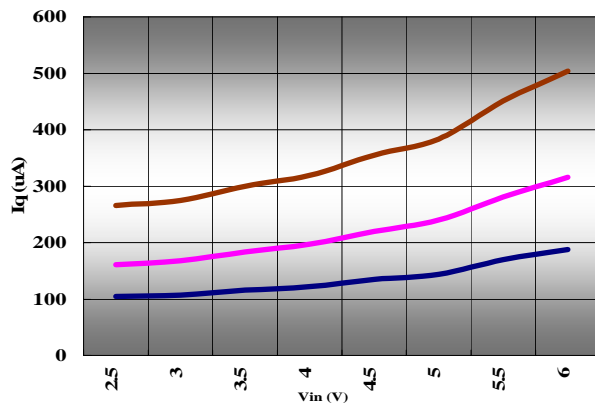

4. Switching Frequency vs Temperature

Figure 5. Fosc vs. Temperature

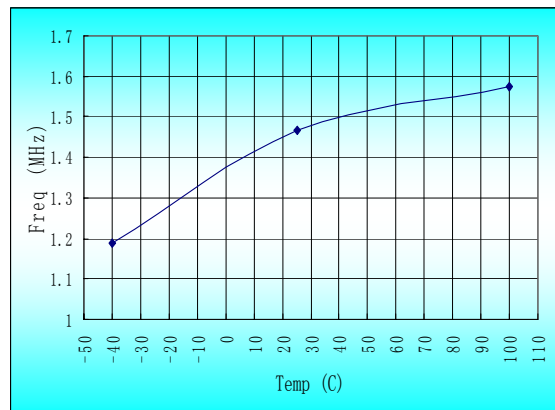

OPERATION

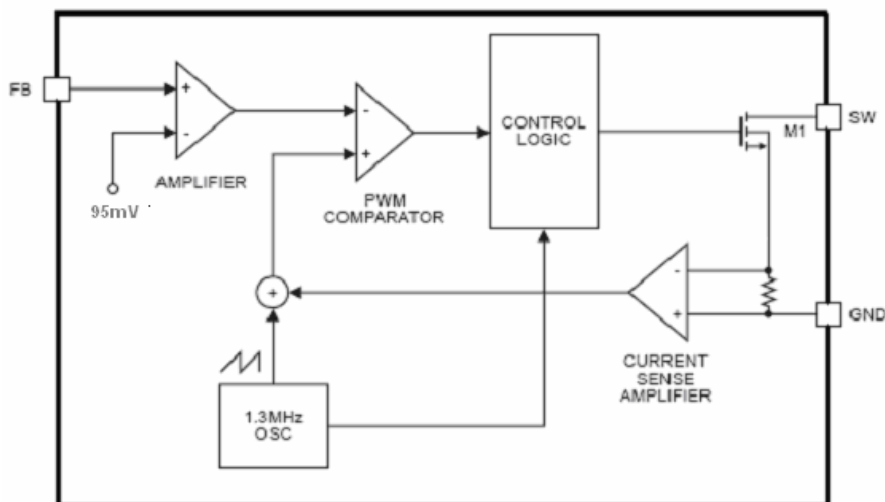

Figure 6. Simplified Block Diagram of the PT4102

The PT4102 uses a constant frequency, peak current mode boost regulator architecture to regulate the series string of white LEDs. The operation of the PT4102 can be understood by referring to the simplified block diagram shown above. At the start of each oscillator cycle, the control logic turns on the power switch M1. The signal at the non-inverting input of the PWM comparator is proportional to the switch current, summed together with a portion of the oscillator ramp. When this signal

reaches the level set by the output of error amplifier, the PWM comparator resets the latch in the control logic and turns off the power switch. In this manner, error amplifier sets the correct peak current level to keep the LED current in regulation. If the feedback voltage starts to drop, the output of the error amplifier increases. This results in more current to flow through M1, hence increasing the power delivered to the output.

APPLICATION INFORMATION

■ Inductor Selections

For most of the applications of the PT4102, it is recommended to use an inductor of 22 μ H. Although small size is one of the major factors in selecting an inductor, the smaller and thinner inductors give higher

core losses at 1.2MHz and DRC, resulting in lower efficiencies. The following table provides a list of recommended inductors:

PART NUMBER	DCR (Ω)	CURRENT RATING (mA)	MANUFACTURER
LQH3C220	0.71	250	MURATA
CDRH3D16-220	0.53	350	SUMIDA
LB2012B220M	1.7	75	TAIYO YUDEN
LEM2520-220	5.5	125	TAIYO YUDEN
EJPC220KF	4.0	160	PANASONIC

■ Capacitor Selection

The small size of ceramic capacitors makes them ideal for PT4101 applications. X5R and X7R types are recommended because they retain their capacitance over wider voltage and temperature ranges than other types

such as Y5V or Z5U. A 1 μ F input capacitor and a 0.22 μ F output capacitor are sufficient for most PT4101 applications.

APPLICATION INFORMATION(Contd.)

■ Diodes Selection

Schottky diodes, with their low forward voltage drop and fast reverse recovery, are the ideal choices for PT4101 applications. The forward voltage drop of a Schottky diode represents the conduction losses in the diode, while the diode capacitance (C_T or C_D) represents the switching losses. For diode selection, both forward voltage drop and diode capacitance need to be considered. Schottky

diodes with higher current ratings usually have lower forward voltage drop and larger diode capacitance, which can cause significant switching losses at the 1.25MHz switching frequency of the PT4101. A Schottky diode rated at 100mA to 200mA is sufficient for most PT4101 applications. Some recommended Schottky diodes are listed in the following table:

PART NUMBER	FORWARD CURRENT (mA)	VOLTAGE DROP (V)	DIODE CAPACITANCE (pF)	MANUFACTURER
CMDSH-3	100	0.58@100mA	7.0@10V	Central
CMDSH2-3	200	0.49@200mA	15@10v	Central
BAT54	200	0.53@100mA	10@25v	Zetex

■ LED Current Control

The LED current is controlled by the feedback resistor. The feedback reference is 104mV. The LED current is $104mV/R_{fb}$. In order to have accurate LED current, precision resistors are preferred (1% is recommended).

The formula and table for R_{FB} selection are shown below:

$$R_{FB} = 104mV/I_{LED} \quad \text{Type E}$$

$$R_{FB} = 88mV/I_{LED} \quad \text{Type S}$$

I_{LED} (mA)	R_{FB} Value (Ω) for type E	R_{FB} Value (Ω) for type S
5	20.8	17.6
10	10.4	8.8
15	6.93	5.87
20	5.2	4.4

■ Open Circuit Protection

In the cases of output open circuit, when the LEDs are disconnected from the circuit or the LEDs fail, the feed-back voltage will be zero. The PT4102 will then switch at a high duty cycle resulting in a high output voltage, which may cause the SW pin voltage to exceed

its maximum 36V rating. A Zener diode can be used at the output to limit the voltage on the SW pin. The Zener voltage should be larger than the maximum forward voltage of the LED string. The current rating of the Zener should be larger than 0.1mA.

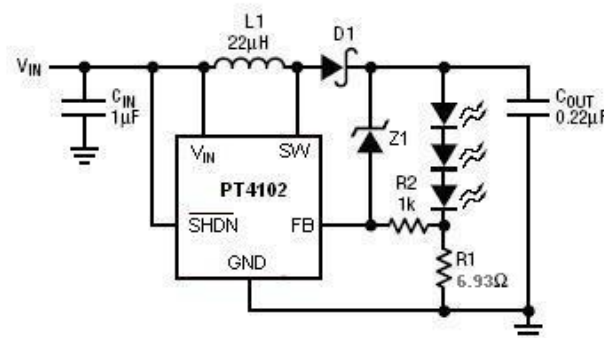

Figure 7. Open Circuit Protection

APPLICATION INFORMATION(Contd.)

■ Dimming Control

There are three different types of dimming control circuits.

1. Using a PWM Signal to $\overline{\text{SHDN}}$ Pin

With the PWM signal applied to the $\overline{\text{SHDN}}$ pin, the PT4102 is turned on or off by the PWM signal. The LEDs operate at either zero or full current. The average LED current increases proportionally with the duty cycle of the PWM signal. A 0% duty cycle will turn off the

PT4102 and corresponds to zero LED current. A 100% duty cycle corresponds to full current. The typical frequency range of the PWM signal is 1kHz to 10kHz. The magnitude of the PWM signal should be higher than the minimum SHDN voltage high.

2. Using a DC Voltage

For some applications, the preferred method of brightness control is a variable DC voltage to adjust the LED current. The dimming control using a DC voltage is shown in Figure 8. As the DC voltage increases, the voltage drop on R2 increases and the voltage drop on R1 decreases. Thus, the LED current decreases. The

selection of R2 and R3 will make the current from the variable DC source much smaller than the LED current and much larger than the FB pin bias current. For V_{DC} range from 0V to 2V, the selection of resistors in Figure 8 gives dimming control of LED current from 0 to 15mA.

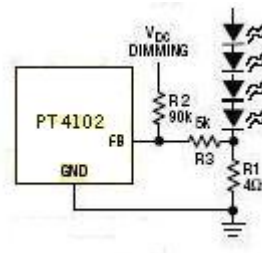

Figure 8. Dimming Control Using a DC Voltage

3. Using a filtered PWM Signal

The filtered PWM signal can be considered as an adjustable DC voltage. It can be used to replace the variable DC voltage source in dimming control.

4. Using a Logic Signal

For applications that need to adjust the LED current in discrete steps, a logic signal can be used as shown in Figure 9. R1 sets the minimum LED current (when the

NMOS is off). R_{INC} sets how much the LED current increases when the NMOS is turned on. The selection of R1 and R_{INC} follows the formula and table below.

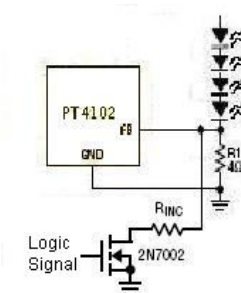

Figure 9. Dimming Control Using a Logic Signal

APPLICATION INFORMATION(Contd.)

Start-up and Inrush Current

No internal soft-start circuit is included in the PT4102. When first turned on without an external soft-start circuit, inrush current is about 200mA. If soft-start is desired, the

recommended circuit is shown in Figure 10. If both soft-start and dimming are used, a 10KHz PWM signal on $\overline{\text{SHDN}}$ is not recommended.

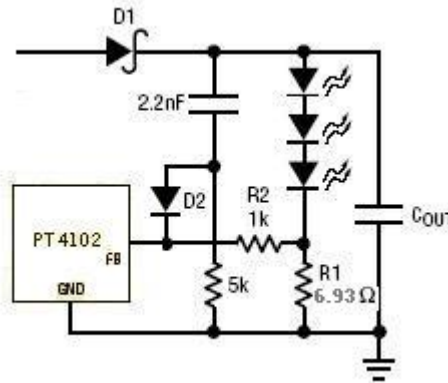
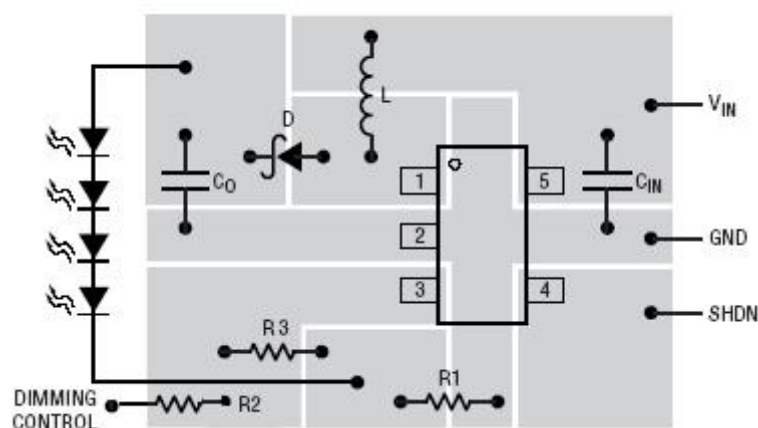

Figure 10. Recommended Soft-Start Circuit

Board Layout Consideration

As with all switching regulators, careful attention must be paid to the PCB board layout and component placement. To maximize efficiency, switch rise and fall times are made as short as possible. To prevent electromagnetic interference (EMI) problems, proper layout of the high frequency switching path is essential. The voltage signal of the SW pin has sharp rise and fall

edges. Minimize the length and area of all traces connected to the SW pin and always use a ground plane under the switching regulator to minimize interplane coupling. In addition, the ground connection for the feedback resistor R1 should be tied directly to the GND pin and not shared with any other component, ensuring a clean, noise-free connection.



PACKAGE INFORMATION

1. SOT-23-5

Plastic SOT-23-5

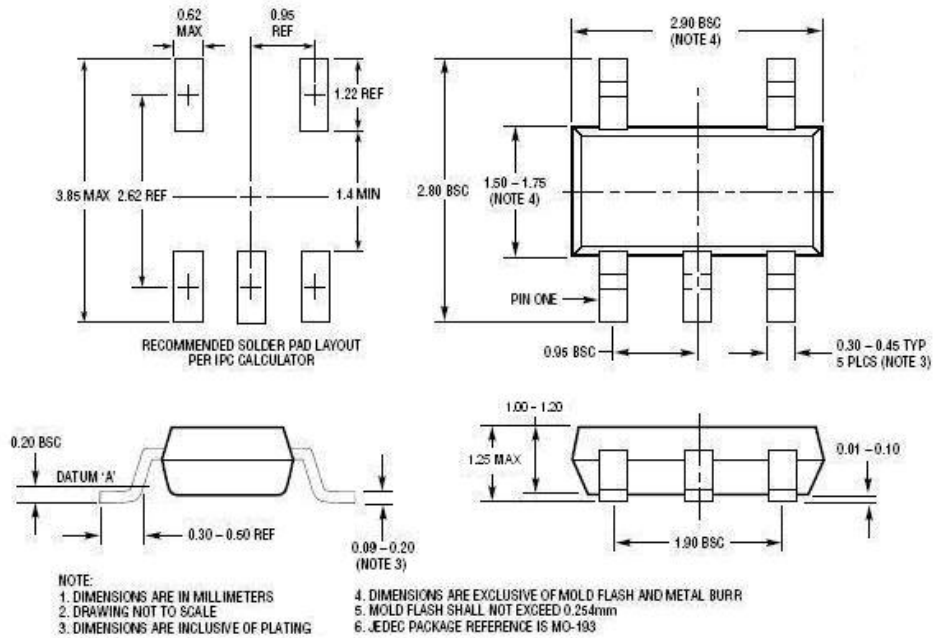

2. SC70-6

Plastic SC70-6

