



MITSUBISHI

MOULDED CASE CIRCUIT BREAKERS

TECHNICAL NOTES

www.DataSheet4U.com



We have the pleasure of providing all our customers with the technical information for Mitsubishi moulded case circuit breakers. This indicates the fundamental data of our circuit breakers regarding the applicable standards, constructional principles, and operational performances. Please refer to the catalogue of our circuit breakers for details of specifications.

Also please stand in need of the handling and maintenance manual for maintaining the circuit breakers in service continuously.

We do hope they are available for all our customers to built more efficient systems.

CONTENTS

1. INTRODUCTION	2	6.8 Coordination with Devices on the High-Voltage Circuit	76
2. FEATURES	3	7. SELECTION	79
2.1 Arc-Extinguishing Device – ISTAC	3	7.1 For Motor Branch Circuits	79
2.2 Digital ETR	4	7.2 For Lighting and Heating Branch Circuits	79
3. CONSTRUCTION AND OPERATION	6	7.3 For Main Circuit	80
4. CHARACTERISTICS AND PERFORMANCE	11	7.4 For Welding Circuits	80
4.1 Overcurrent-Trip Characteristics	11	7.5 For Transformer-Primary Use	82
4.2 Short-Circuit Trip Characteristics	11	7.6 For Capacitor Circuits	83
4.3 Effects of Mounting Attitudes	12	7.7 For Thyristor Circuits	84
4.4 DC Tripping Characteristics of AC-Rated MCCBs	12	7.8 MDU Breaker	90
4.5 Frequency Characteristics	12	7.9 Selection of MCCBs in inverter circuit	93
4.6 Switching Characteristics	13	8. ENVIRONMENTAL CHARACTERISTICS	95
4.7 Dielectric Strength	13	8.1 Atmospheric Environment	95
5. CIRCUIT BREAKERS SELECTION	14	8.2 Vibration-Withstand Characteristics	96
5.1 Circuit Breakers Selection Table	14	8.3 Shock-Withstand Characteristics	97
6. PROTECTIVE CO-ORDINATION	39	9. SHORT-CIRCUIT CURRENT CALCULATIONS	98
6.1 General	39	9.1 Purpose	98
6.2 Interrupting Capacity Consideration	40	9.2 Definitions	98
6.3 Selective-Interruption	41	9.3 Impedances and Equivalent Circuits of Circuit Components	98
6.4 Cascade Back-up Protection	68	9.4 Classification of Short-Circuit Current	101
6.5 I ² t Let-Through Characteristics and Current Limiting Characteristics	70	9.5 Calculation Procedures	102
6.6 Protective Coordination with Wiring	71		
6.7 Protective Coordination with Motor Starters	74		

1. INTRODUCTION

Mitsubishi Advancing Technology

Mitsubishi, the leading manufacturer of circuit breakers, has been providing customers with a wide range of highly reliable and safe moulded case circuit breakers (MCCB) and earth-leakage circuit breakers (ELCB), corresponding to the needs of the age.

Since production began in 1933 many millions of Mitsubishi ACBs, MCCBs and MCBs have been sold throughout many countries.

In 1985 a new design concept for controlling arc energies within MCCBs – vapour jet control (VJC) – was introduced and significantly improved performance. It is provided the technological advance for a new ‘super series’ range of MCCBs and is used in all present ratings from 3 to 1600 amps.

In 1995 Mitsubishi offers the new PSS (Progressive Super Series) breakers having ratings from 3 to 250 amps that concentrate the most advanced technologies into a compact body. Their four major features are:

- New circuit-breaking technology ISTAC for a higher current-limiting performance, upgrading the circuit-breaking capability.
- Electronic circuit breakers with the Digital ETR protecting the circuit accurately.
- One-frame, one-size design allowing efficient panel design.
- Cassette-type internal accessories that allow installation by the user.

Progressive Super Series, an integration of technology and know-how from this comprehensive electronic product manufacturer, will create its own fields of application with its excellent performance.

A Brief Chronology

1933	Moulded case circuit breaker production begins.
1952	Miniature circuit breaker production begins.
1968	Manufacture commences of short-time-delayed breakers.
1969	Production and sale of first residual current circuit breakers.
1970	170kA breaking level ‘permanent power fuse’ integrated MCCBs is introduced.
1973	Introduction of first short-time delay and current-limiting selectable breakers go on sale.
1974	First MELNIC solid-state electronic trip unit MCCBs are introduced.
1975	ELCBs with solid-state integrated circuit sensing devices are introduced.
1977-1979	Four new ranges of MCCBs are introduced – economy, standard, current limiting, ultra current limiting and motor rated designs – a comprehensive coverage of most application requirements.
1982	Compact ACBs with solid-state trip devices and internally mounted accessories introduced.
1985-1989	Super series MCCBs with VJC and ETR are developed and launched – awarded the prestigious Japanese Minister of Construction Prize.
1990	New 200kA level U-series MCCBs super current limiting breakers are introduced.
1991	Super-NV ELCBs and Super-AE ACBs are introduced.
1995	Progressive Super Series 30~250 amps are introduced.
1997	Progressive Super Series 400~800 amps are introduced.

2. FEATURES – Advanced MCCB Design Technology & Performance

2.1 Arc-Extinguishing Device – ISTAC

Mitsubishi has developed an epoch-making ISTAC technology to realize an improved current-limiting and breaking performance within a smaller breaking space. Introduction of ISTAC technology upgrades the current-limiting, selective-breaking, and cascade-breaking performance. The maximum peak let-through current I_p decreases to about 80% (compared with Mitsubishi's 100AF). The passing energy I_2t decreases to about 65% (compared with Mitsubishi's 100AF). The smaller breaking space has led to an improved function, a smaller size, and a standardization of the breakers.

Triple forces accelerating

The triple forces generated by a newly designed current pass and the Vapor Jet Control (VJC) insulating materials which makes up a slot-type breaking construction accelerate the movable conductor, and separate the contacts faster than ever before in short-breaking.

Electromagnetic attractive force which works between a current of the movable conductor and a current of the fixed upper conductor.

Electromagnetic repulsive force which works between a current of the movable conductor and a current of the fixed lower conductor.

Pressure which works on the movable conductor by gas generated in the slot.

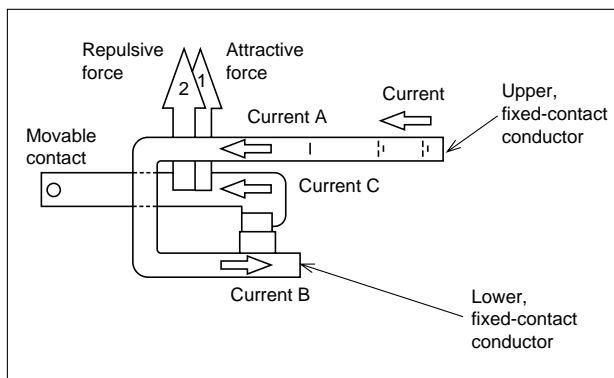

Arc control by slot-breaking

The VJC of the fixed contact incorporates newly developed insulation made of ceramic fiber and metal hydroxide. This substantially improves the VJC effect. The arc-extinguishing gas energies to improve the capability of extinguishing the arc.

The VJC suppresses the emergence of carbide products in breaking a current and contribute to the recovery of insulation immediately thereafter.

The VJCs on the fixed and movable contacts work together to forcefully reduce the arc spot and rapidly contract the total arc being extinguished.

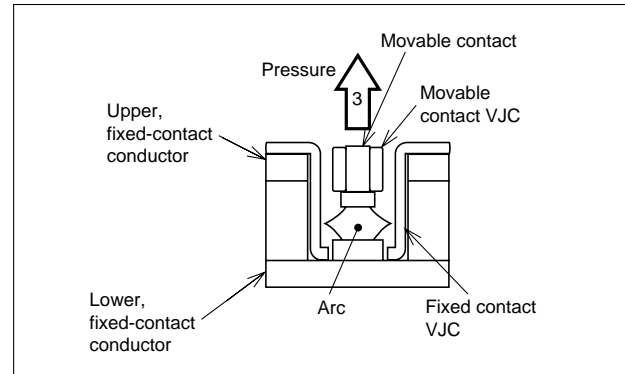

Vapor jet control (VJC)

Vapor Jet Controllers made of insulating material are arranged around the contacts where they control the arc as follows:

1. The arc spot is forcibly reduced by the arrangement of the insulating material.
2. The arc column is contracted.
3. Adiabatic expansion cools the arc.
4. The arc is transferred at the optimum moment to the arc-extinguishing chamber by the arrangement of the Vapor Jet Controllers.

2.2 Digital ETR (Electronic Trip Relay)

Mitsubishi's electronic MCCBs are equipped with a digital ETR to enable fine protection. The digital ETR contains Mitsubishi's original double IC (8 bit microcomputer and custom-IC).

Digital detection of the effective value

Electronic devices such as an inverter distort the current waveform. Mitsubishi's PSS electronic breakers are designed to detect digitally the effective value of the current to minimize over-current tripping errors. This enables fine protection for the system.

Processing of the digital ETR

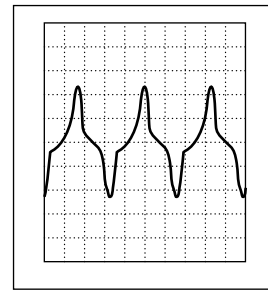

Sampling and A/D conversion



Calculating the digitally effective value



Processing the long time-delay pre-alarm characteristics

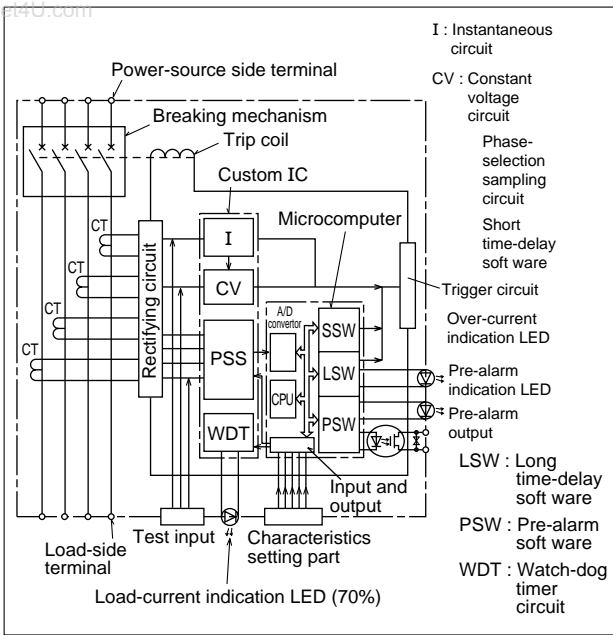

Standard equipped pre-alarm system

Mitsubishi's PSS electronic breakers have a pre-alarm system as a standard. When the load current exceeds the set pre-alarm current, the breaker lights up an LED and outputs a pre-alarm signal.

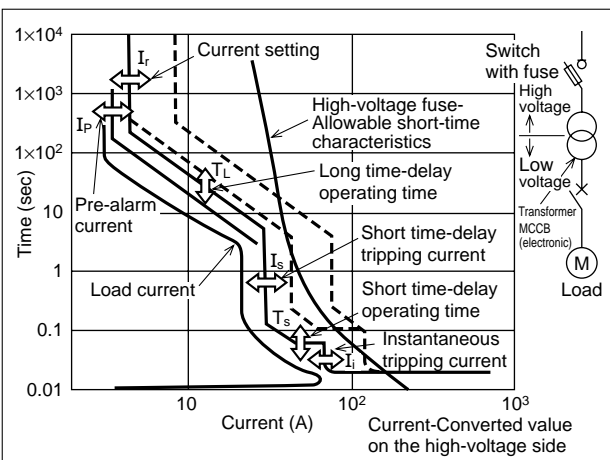

2.3 Equipment of High Technology

Series	Type	Advanced Technology			
		ISTAC	VJC	Digital-ETR	Analog-ETR
NF-S	NF30-SP				
	NF50-HP				
	NF50-HRP	●	●		
	NF60-HP				
	NF100-SP	●	●		
	NF100-HP	●	●		
	NF100-SEP	●	●	●	
	NF100-HEP	●	●	●	
	NF160-SP		●		
	NF160-HP	●	●		
	NF250-SP		●		
	NF250-HP	●	●		
	NF250-SEP	●	●	●	
	NF250-HEP	●	●	●	
	NF400-SP		●		
	NF400-SEP		●	●	
	NF400-HEP		●	●	
	NF400-REP		●	●	
	NF630-SP		●		
	NF630-SEP		●	●	
	NF630-HEP		●	●	
	NF630-REP		●	●	
	NF800-SEP		●	●	
	NF800-HEP		●	●	
	NF800-REP		●	●	
	NF1000-SS				●
	NF1250-SS				●
	NF1600-SS				●
NF-C	NF50-CP				
	NF60-CP				
	NF100-CP				
	NF250-CP				
	NF400-CP				
	NF630-CP				
	NF800-CEP		●	●	
NF-U	NF100-RP	●	●		
	NF100-UP	●	●		
	NF225-RP		●		
	NF225-UP	●	●		
	NF400-UEP		●	●	
	NF630-UEP		●	●	
	NF800-UEP		●	●	
	NF1250-UR				●

3. CONSTRUCTION AND OPERATION

3.1 General

The primary components are: a switching mechanism, an automatic tripping device (and manual trip button), contacts, an arc-extinguishing device, terminals and a molded case.

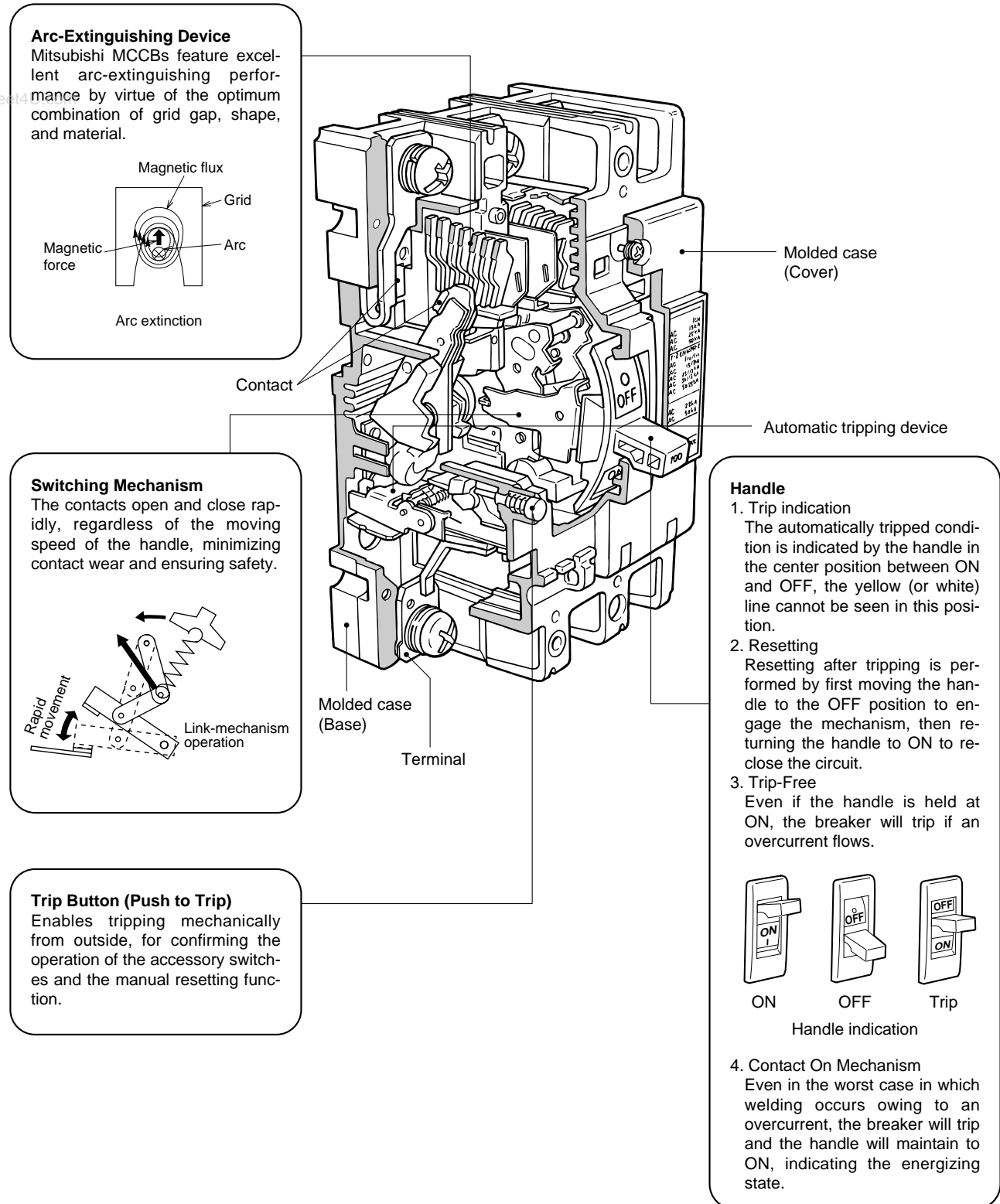

Fig. 3.1 Type NF100-SP Construction

3.2 Switching Mechanism

The ON, OFF and TRIPPED conditions are shown in Fig. 3.2. In passing from ON to OFF, the handle tension spring passes through alignment with the toggle link ("dead point" condition). In so doing, a positive, rapid contact-opening action is produced; the OFF to ON contact closing acts in a similar way ("quick make" and "quick break" actions). In both cases the action of the contacts is always rapid and positive, and independent of the human element – i.e., the force or speed of the handle.

In auto tripping a rotation of the bracket releases the cradle and operates the toggle link to produce the contact-opening action described above. In the tripped condition the handle assumes the center position between on and off, providing a visual indication of the tripped condition. Also, auto trip is "trip free," so that the handle cannot be used to hold the breaker in the ON condition. The protective contact-opening function cannot be defeated.

In multipole breakers the poles are separated by integral barriers in the molded case. The moving contacts of the poles are attached to the central toggle link by a common-trip bar, however, so that tripping, opening and closing of all poles is always simultaneous. This is the "common trip" feature, by which single phasing and similar unbalance malfunctions are effectively prevented.

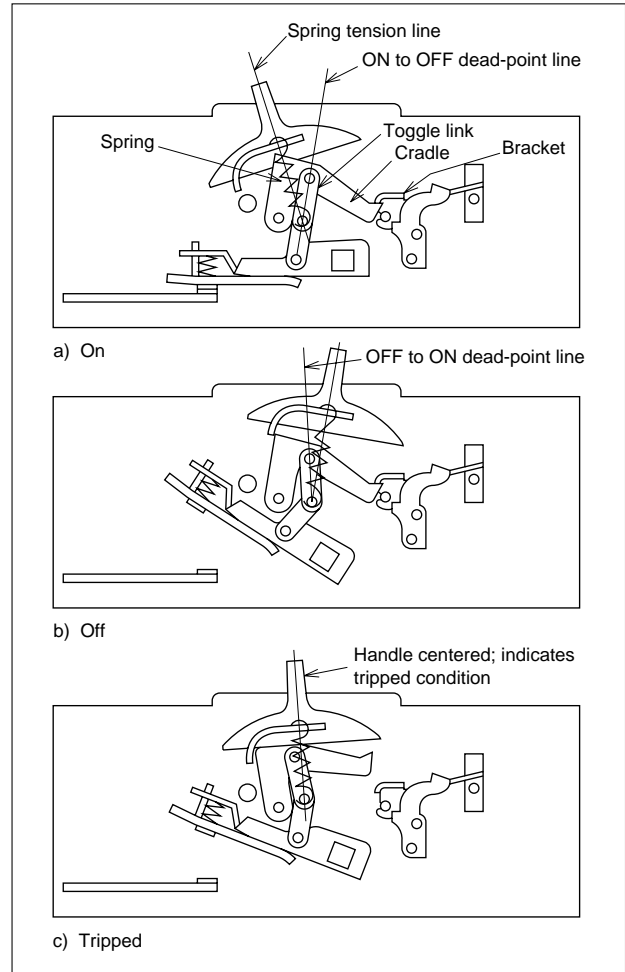

Fig. 3.2 Switching Mechanism Action

3.3 Automatic Tripping Device

There are three types of device, the thermal-magnetic type, the hydraulic-magnetic type and the electronic trip relay type.

■ Automatic Tripping Devices

● Thermal-Magnetic Type (100~800A Frame)

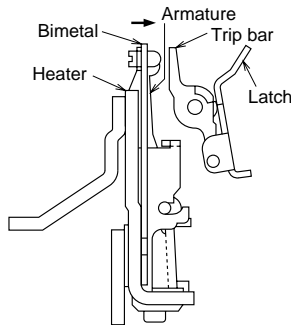

Fig. 3.3

1. Time-Delay Operation
An overcurrent heats and warps the bi-metal to actuate the trip bar.
2. Instantaneous Operation
If the overcurrent is excessive, the armature is attracted and the trip bar actuated.

● Thermal-Magnetic Type (1000~4000A Frame)

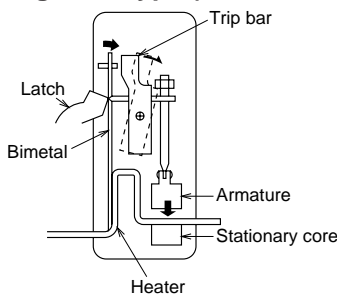

Fig. 3.4

1. Time-Delay Operation
An overcurrent heats and warps the bi-metal to actuate the trip bar.
2. Instantaneous Operation
If the overcurrent is excessive, magnetization of the stationary core is strong enough to attract the armature and actuate the trip bar.

● Hydraulic-Magnetic Type (30~60A Frame)

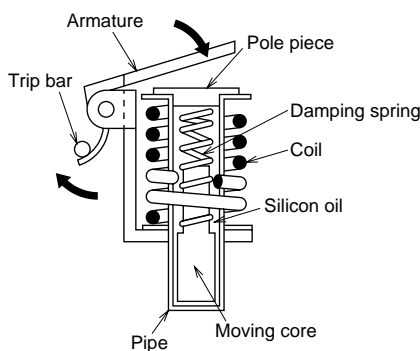

Fig. 3.5

1. Time-Delay Operation
At an overcurrent flow, the magnetic force of the coil overcomes the spring, the core closes to the pole piece, attracts the armature, and actuates the trip bar. The delay is obtained by the viscosity of silicon oil.
2. Instantaneous Operation
If the overcurrent is excessive, the armature is instantly attracted, without the influence of the moving core.

● Principle of Electronic Trip Relay (ETR) Operation

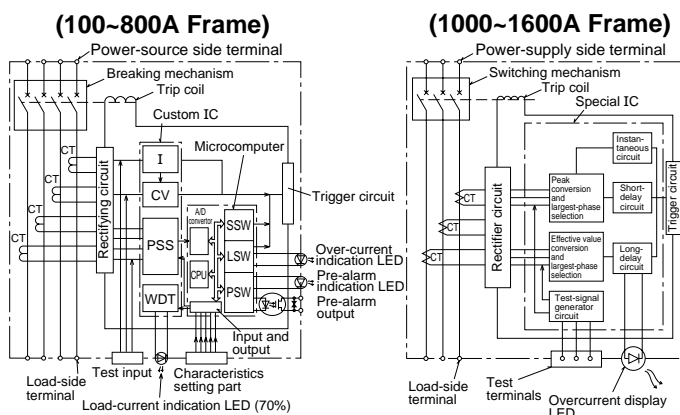

Fig. 3.6

1. The current flowing in each phase is monitored by a current transformer (CT).
2. Each phase of the transformed current undergoes full-phase rectification in the rectifier circuit.
3. After rectification, each of the currents are converted by a peak-conversion and an effective-value conversion circuit.
4. The largest phase is selected from the converted currents.
5. Each time-delay circuit generates a time delay corresponding to the largest phase.
6. The trigger circuit outputs a trigger signal.
7. The trip coil is excited, operating the switching mechanism.

Table 3.1 Comparison of Thermal-Magnetic, Hydraulic-Magnetic and Electronic Types

Item	Thermal-magnetic type	Hydraulic-magnetic type	Electronic type
Ambient temperature	<p>Operating current is affected by ambient temperature (bimetal responds to absolute temperature not temperature rise).</p>	<p>Affected only to the extent that the damping-oil viscosity is affected.</p>	<p>Negligible effect</p>
Frequency	<p>Negligible effect up to several hundred Hz; above that the instantaneous trip is affected due to increased iron losses.</p>	<p>Trip current increases with frequency, due to increased iron losses.</p>	<p>Tripping current of some types decrease due to CT or condition of operating circuit with high frequency, and others increase.</p>
Distorted wave	<p>Negligible effect up to 600A; Above that operating current decreases due to increase of a fever.</p>	<p>IF distortion is big, minimum operating current increases.</p>	<p>For peak value detection, operating current drops.</p>
Mounting attitude	<p>Negligible effect.</p>	<p>Mounting attitude changes the effective weight of the magnetic core.</p>	<p>Negligible effect</p>
Flexibility of operating characteristics	<p>Bimetal must provide adequate deflection force and desired temperature characteristic. Operating time range is limited.</p>	<p>Oil viscosity, cylinder, core and spring design, etc., allow a wide choice of operating times.</p>	<p>Operating time can be easily shortened. To lengthen operating time is not.</p>
Flexibility of rated current	<p>Units for small rated currents are physically impractical.</p>	<p>Coil winding can easily be designed to suit any ampere rating.</p>	<p>Within the range of 50(60)-100% of rated current, any ampere rating are practical. Also, to lower the value of short-time delay or instantaneous trip can be easily done comparatively.</p>

3.4 Contacts

A pair of contacts comprises a moving contact and a fixed contact. The instants of opening and closing impose the most severe duty. Contact materials must be selected with consideration to three major criteria:

1. Minimum contact resistance
2. Maximum resistance to wear
3. Maximum resistance to welding

Silver or silver-alloy contacts are low in resistance, but wear rather easily. Tungsten, or majority-tungsten alloys are strong against wear due to arcing, but rather high in contact resistance. Where feasible, 60%+ silver alloy (with tungsten carbide) is used for contacts primarily intended for current carrying, and 60%+ tungsten alloy (with silver) is used for contacts primarily intended for arc interruption. Large-capacity MCCBs employ this arrangement, having multicontact pairs, with the current-carrying and arc-interruption duties separated.

3.5 Arc-Extinguishing Device

Arcing, an inevitable aspect of current interruption, must be extinguished rapidly and effectively, in normal switching as well as protective tripping, to minimize deterioration of contacts and adjacent insulating materials. In Mitsubishi MCCBs a simple, reliable, and highly effective "de-ion arc extinguisher," consisting of shaped magnetic plates (grids) spaced apart in an insulating supporting frame, is used (Fig. 3.7). The arc (ionized-path current) induces a flux in the grids that attracts the arc, which tends to "lie down" on the grids, breaking up into a series of smaller arcs, and also being cooled by the grid heat conduction. The arc (being effectively longer) thus requires far more voltage to sustain it, and (being cooler) tends to lose ionization and extinguish. If these two effects do not extinguish the arc, as in a very large fault, the elevated temperature of the insulating frame will cause gasing-out of the frame material, to de-ionize the arc. Ac arcs are generally faster extinguishing due to the zero-voltage point at each half cycle.

3.6 Molded Case

The integral molded cases used in Mitsubishi MCCBs are constructed of the polyester resin containing glass fibers, the phenolic resin or glass reinforced nylon. They are designed to be suitably arc-, heat- and gas-resistant, and to provide the necessary insulating spacings and barriers, as well as the physical strength required for the purpose.

3.7 Terminals

These are constructed to assure electrical efficiency and reliability, with minimized possibility of localized heating. A wide variety of types are available for ease of mounting and connection. Compression-bonded types and bar types are most commonly used.

3.8 Trip Button

This is a pushbutton for external, mechanical tripping of the MCCB locally, without operating the external-accessory shunt trip or undervoltage trip, etc. It enables easy checking of breaker resetting, control-circuit devices associated with alarm contacts, etc., and resetting by external handle.

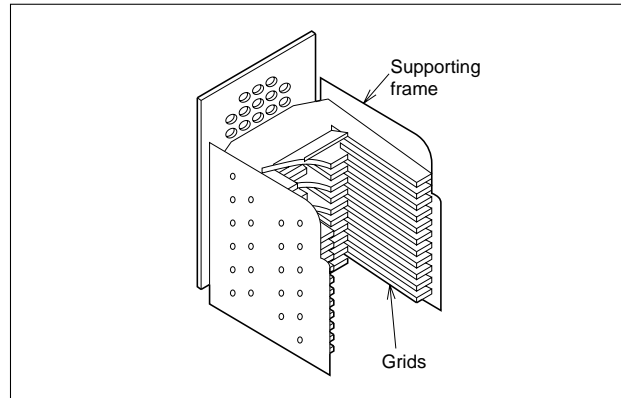

Fig. 3.7 The De-Ion Arc Extinguisher

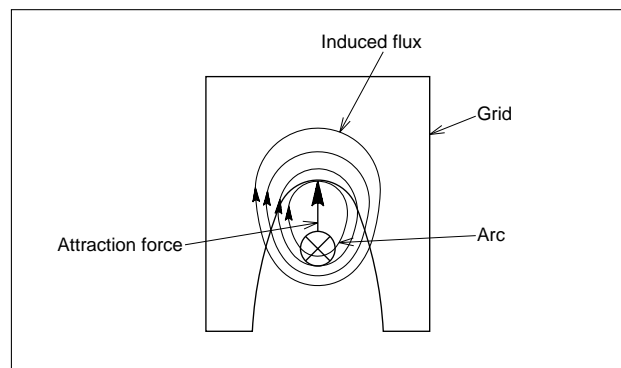

Fig. 3.8 The Induced-Flux Effect

4. CHARACTERISTICS AND PERFORMANCE

4.1 Overcurrent-Trip Characteristics (Delay Tripping)

Tripping times for overcurrents of 130 and 200% of rated current are given in Table 4.1, assuming ambient temperatures of 40°C, a typical condition inside of panelboards. The figures reflect all poles tested together for 130% tripping, and 105% non-tripping. Within the range of the long-delay-element (thermal or hydraulic) operation, tripping times are substantially linear, in inverse relationship to overcurrent magnitude.

The tripping times are established to prevent excessive conductor-temperature rise; although times may vary among MCCBs of different makers, the lower limit is restricted by the demands of typical loads: tungsten-lamp inrush, starting motor, mercury-arc lamps, etc. The tripping characteristics of Mitsubishi MCCBs are established to best ensure protection against abnormal currents, while avoiding nuisance tripping.

4.1.1 Ambient Temperature and Thermal Tripping

Fig. 4.1 is a typical ambient compensation curve (curves differ according to types and ratings), showing that an MCCB rated for 40°C ambient use must be derated to 90% if used in a 50°C environment. In an overcurrent condition, for the specified tripping time, tripping would occur at 180% rated current, not 200%. At 25°C, for the same tripping time, tripping would occur at 216%, not 200%.

4.1.2 Hot-State Tripping

The tripping characteristics described above reflect “cold-state tripping” – i.e., overloads increased from zero – and the MCCB stabilized at rated ambient. This is a practical parameter for most uses, but in intermittent operations, such as resistance welding, motor pulsing, etc., the “hot state” tripping characteristic must be specified, since overloads are most likely to occur with the MCCB in a heated state, while a certain load current is already flowing.

Where the MCCB is assumed to be at 50% of rating when the overload occurs, the parameter is called the 50% hot-state characteristic; if no percentage is specified, 100% is assumed. Hot-state ratings of 50% and 75% are common.

4.2 Short-Circuit Trip Characteristics (Instantaneous Tripping)

For Mitsubishi MCCBs with thermal-magnetic trip units the instantaneous-trip current can be specified independently of the delay characteristic, and in many cases this parameter is adjustable offering considerable advantage in coordination with other protection and control devices. For example, in coordination with motor starters, it is important to set the MCCB instantaneous-trip element at a lower value than the fusing (destruction) current of the thermal overload relay

(OLR) of the starter.

For selective tripping, it must be remembered that even though the branch-MCCB tripping time may be shorter than the total tripping time of the main MCCB, in a fault condition the latter may also be tripped because its latching curve overlaps the tripping curve of the former. The necessary data for establishing the required compatibility is provided in the Mitsubishi MCCB sales catalogues.

The total clearing time for the “instantaneous” tripping feature is shown in Fig. 4.3; actual values differ for each MCCB type.

Table 4.1 Overcurrent Tripping Times

Rated current (A)	Tripping time (minutes, max.)		Non-Tripping time (minutes, max.)
	200%	130%	105%
30 or less	8.5	60	60
31~63	4	60	60
64~100	8.5	120	120
101~250	8	120	120
251~400	10	120	120
401~630	12	120	120
631~800	14	120	120
801~1000	16	120	120
1001~1250	18	120	120
1251~1600	20	120	120
1601~2000	22	120	120
2001~4000	24	120	120

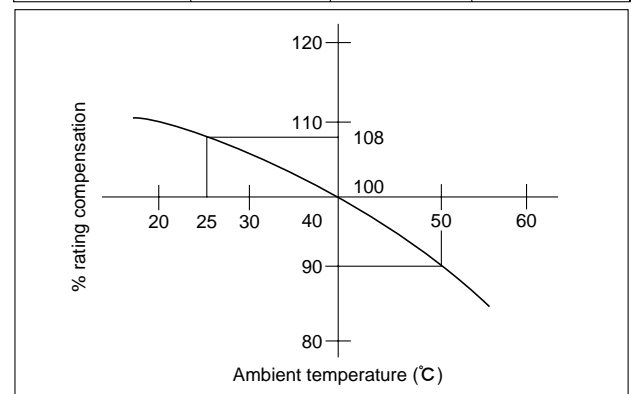

Fig. 4.1 Typical Temperature-Compensation Curve

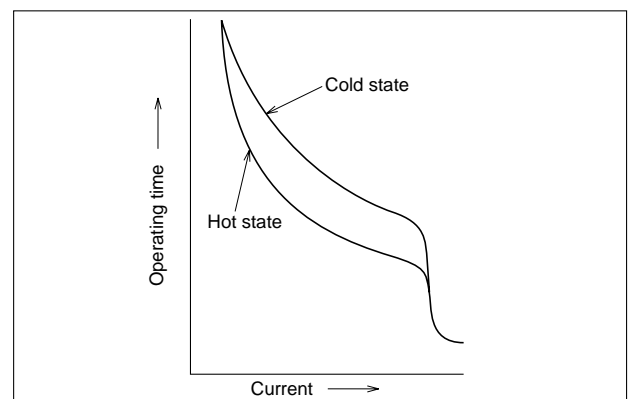

Fig. 4.2 Hot-State-Tripping Curve

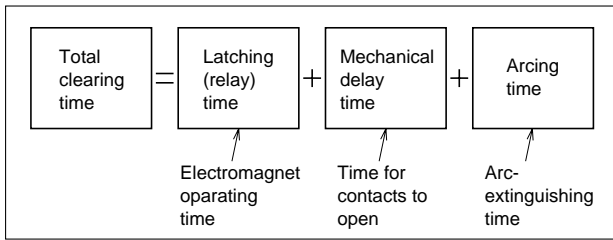

Fig. 4.3 Instantaneous Tripping Sequence

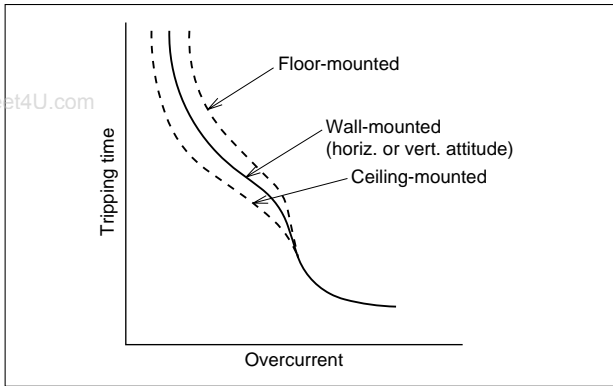

Fig. 4.4 Effect of Mounting Attitude on the Hydraulic-Magnetic MCCB Tripping Curves

4.3 Effects of Mounting Attitudes

Instantaneous tripping is negligibly affected by mounting attitude, for all types of MCCB. Delay tripping is also negligibly affected in the thermal types, but in the hydraulic-magnetic types the core-weight effect becomes a factor. Fig. 4.4 shows the effect, for vertical-surface mounting and for two styles of horizontal-surface mounting.

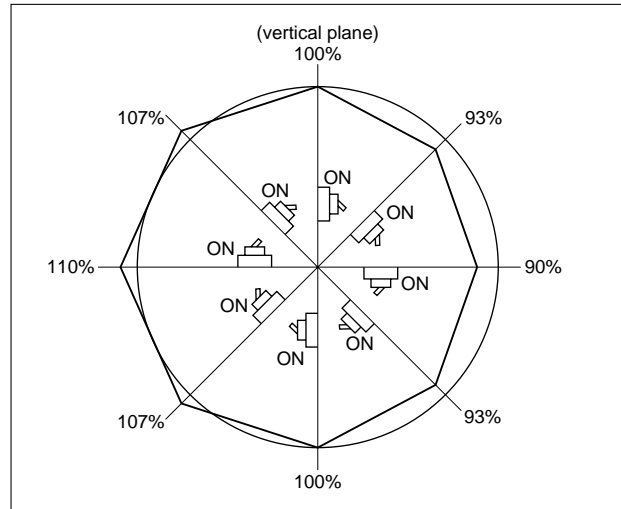

Fig. 4.5 Effects of Nonvertical-Plane Mounting on Current Rating

4.4 DC Tripping Characteristics of AC-Rated MCCBs

Table 4.2 DC Tripping Characteristics

Trip unit	Long delay	Instantaneous	Tripping curve
Thermal magnetic	No effect below 630A frame. Above this, AC types cannot be used for DC.	DC inst.-trip current is approx. 130% of AC value.	
Hydraulic magnetic	DC minimum-trip values are 110~140% of AC values.		

4.5 Frequency Characteristics

At commercial frequencies the characteristics of Mitsubishi MCCBs of below 630A frame size are virtually constant at both 50Hz and 60Hz (except for the E Line models, the characteristics of MCCBs of 800A frame and above vary due to the CT used with the delay element).

At high frequencies (e.g., 400Hz), both the current capacity and delay tripping curves will be reduced by skin effect and increased iron losses.

Performance reduction will differ for different types; at 400Hz it will become 80% of the rating in breakers of maximum rated current for the frame size, and 90%

of the rating in breakers of half of the maximum rating for the frame size.

The instantaneous trip current will gradually increase with frequency, due to reverse excitation by eddy currents. The rise rate is not consistent, but around 400Hz it becomes about twice the value at 60Hz. Mitsubishi makes available MCCBs especially designed for 400Hz use. Apart from operating characteristics they are identical to standard MCCBs (S Line).

4.6 Switching Characteristics

The MCCB, specifically designed for protective interruption rather than switching, and requiring high-contact pressure and efficient arc-extinguishing capability, is expected to demonstrate inferior capability to that of a magnetic switch in terms of the number of operations per minute and operation life span. The specifications given in Table 4.3 are applicable where the MCCB is used as a switch for making and break-

ing rated current.

Electrical tripping endurance in MCCBs with shunt or undervoltage tripping devices is specified as 10% of the mechanical-endurance number of operations quoted in IEC standards.

Shunt tripping or undervoltage tripping devices are intended as an emergency trip provision and should not be used for normal circuit-interruption purposes.

Table 4.3 MCCB Switching Endurance

Frame size	Operations per hour	Number of operations		
		Without current	With current	Total
100 or less	120	8500	1500	10000
225	120	7000	1000	8000
400, 630	60	4000	1000	5000
800	20	2500	500	3000
1000~2000	20	2500	500	3000
2500, 3000	10	1500	500	2000
3200, 4000	10	1500	500	2000

4.7 Dielectric Strength

In addition to the requirements of the various international standards, Mitsubishi MCCBs also have the impulse-voltage withstand capabilities given below (Table 4.4). The impulse voltage is defined as sub-

stantially square-wave, with a crest length of 0.5~1.5 μ sec and a tail-length of 32~48 μ sec. The voltage is applied between line and load terminals (MCCB off), and between live parts and ground (MCCB on).

Table 4.4 MCCB Impulse Withstand Voltage (Uimp)

Line	Type	Impulse-voltage (kA)
MB	MB30-CS	4
	MB30-SP MB50-CP MB50-SP MB100-SP MB225-SP	6
NF	NF30-SP NF50-HP NF60-HP NF50-HRP NF100-SP NF100-HP NF100-SEP NF100-HEP NF160-SP NF160-HP NF250-SP NF250-HP NF250-SEP NF250-HEP	6
	NF400-SP NF400-SEP NF400-HEP NF400-REP NF630-SP NF630-SEP NF630-HEP NF630-REP NF800-SEP NF800-HEP NF800-REP NF800-REP NF1000-SS NF1250-SS NF1600-SS	8
	NF30-CS	4
	NF50-CP NF60-CP NF100-CP NF250-CP NF400-CP NF630-CP NF800-CEP	6 8
	NF100-RP NF100-UP NF225-RP NF225-UP NF400-UEP NF630-UEP NF800-UEP	6 8

5. CIRCUIT BREAKER SELECTION

5.1 Circuit Breaker Selection Table

Following Table shows various characteristics of each breaker to consider selection and coordination with upstream devices or loads.

Characteristics

Standard : Standard characteristics MCCBs

Low-inst : Low-inst. MCCBs for Discrimination

When a power fuse (PF) is used as a high-voltage protector, it must be coordinated with an MCCBs on the secondary side.

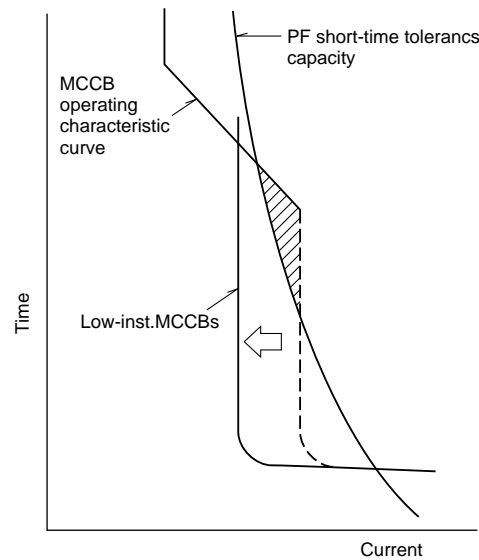
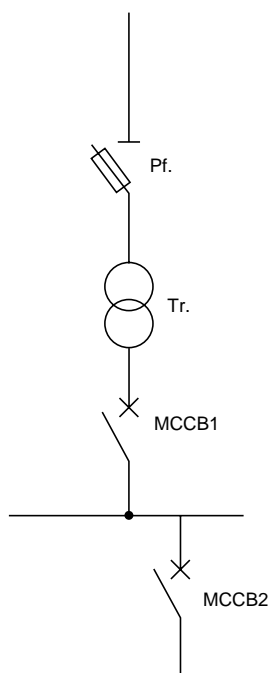

Generator : Generator-Protection MCCBs

These MCCBs have long-time-delay operation shorter than standard type and low instantaneous operation.

Mag-Only : Magnetic trip only MCCBs

These are standard MCCBs minus the thermal tripping device. They have no time-delay tripping characteristic, providing protection only against large-magnitude short-circuit faults.

CIRCUIT BREAKER SELECTION TABLE

Frame (A)		30			50								
Type		NF30-CS			NF30-SP			NF50-CP					
Rated current In (A)		3, 5, 10, 15, 20, 30			3, 5, 10, 15, 20, 30			10, 15, 20, 30, 40, 50					
Rated insulation voltage Ui (V) AC		500			600			600					
AC Breaking capacity (kA rms) IEC60947-2 Icu/Ics	690V	-			-			-					
	500V	-			2.5/1			2.5/1					
	440V	1.5/1.5 (415V)			2.5/1			2.5/1					
	400V	1.5/1.5 (380V)			5/2			5/2					
	230V	2.5/2 (240V)			5/2			5/2					
Standard	Number of poles	2 3			2 3			2 3					
	Automatic tripping device	Hydraulic-magnetic Fixed ampere rating and instantaneous			Hydraulic-magnetic Fixed ampere rating and instantaneous			Hydraulic-magnetic Fixed ampere rating and instantaneous					
	Rating (A) and Inst. (A)	3	39	±	17	3	33	±	10	10	110	±	35
		5	66	±	28	5	55	±	17	15	165	±	52
10		132	±	57	10	110	±	35	20	220	±	70	
15		198	±	86	15	165	±	52	30	330	±	105	
20		265	±	115	20	220	±	70	40	440	±	140	
30		397	±	172	30	330	±	105	50	550	±	175	
Low-inst	Number of poles	-			-			-					
	Automatic tripping device	-			-			-					
	Rating (A) and Inst. (A)	-			-			-					
Generator	Number of poles	-			-			-					
	Automatic tripping device	-			-			-					
	Rating (A) and Inst. (A)	-			-			-					
Mag-Only	Number of poles	-			2 3			2 3					
	Automatic tripping device	-			Magnetic Fixed ampere rating instantaneous			Magnetic Fixed ampere rating instantaneous					
	Rating (A) and Inst. (A)	-			3	30	±	6	10	100	±	20	
-			5	50	±	10	15	150	±	30			
-			10	100	±	20	20	200	±	40			
-			15	150	±	30	30	300	±	60			
-			20	200	±	40	40	400	±	80			
-			30	300	±	60	50	500	±	100			

Frame (A)		50			60		
Type		NF50-HP			NF60-CP		
Rated current In (A)		10, 15, 20, 30, 40, 50			10, 15, 20, 30, 40, 50, 60		
Rated insulation voltage Ui (V) AC		600			600		
AC Breaking capacity (kA rms) IEC60947-2 Icu/Ics	690V	-			-		
	500V	7.5/4			2.5/1		
	440V	10/5			2.5/1		
	400V	10/5			5/2		
	230V	25/13			5/2		
Standard	Number of poles	2 3 4			2 3		
	Automatic tripping device	Hydraulic-magnetic Fixed ampere rating and instantaneous			Hydraulic-magnetic Fixed ampere rating and instantaneous		
	Rating (A) and Inst. (A)	10 110 ± 35	10 110 ± 35		15 165 ± 52	15 165 ± 52	
		20 220 ± 70	20 220 ± 70		30 330 ± 105	30 330 ± 105	
40 440 ± 140		40 440 ± 140		50 550 ± 175	50 550 ± 175		
50 550 ± 175		50 550 ± 175		60 660 ± 210	60 660 ± 210		
60 660 ± 210		60 660 ± 210					
Low-inst	Number of poles	-			-		
	Automatic tripping device	-			-		
	Rating (A) and Inst. (A)	-			-		
Generator	Number of poles	-			-		
	Automatic tripping device	-			-		
	Rating (A) and Inst. (A)	-			-		
Mag-Only	Number of poles	2 3 4			2 3		
	Automatic tripping device	Magnetic Fixed ampere rating and instantaneous			Magnetic Fixed ampere rating and instantaneous		
	Rating (A) and Inst. (A)	10 100 ± 20	10 100 ± 20		15 150 ± 30	15 150 ± 30	
		20 200 ± 40	20 200 ± 40		30 300 ± 60	30 300 ± 60	
40 400 ± 80		40 400 ± 80		50 500 ± 100	50 500 ± 100		
50 500 ± 100		50 500 ± 100		60 600 ± 120	60 600 ± 120		
60 600 ± 120		60 600 ± 120					

Frame (A)		60			100					
Type		NF60-HP			NF100-CP			NF100-SP		
Rated current In (A)		10, 15, 20, 30, 40, 50, 60			50, 60, 75, 100			15, 20, 30, 40, 50, 60, 75, 100		
Rated insulation voltage Ui (V) AC		600			600			690		
AC Breaking capacity (kA rms) IEC60947-2 Icu/Ics	690V	-			-			-		
	500V	7.5/4			7.5/4			15/8		
	440V	10/5			10/5			25/13		
	400V	10/5			10/5			30/15		
	230V	25/13			25/13			50/25		
Standard	Number of poles	2 3 4			2 3			2 3 4		
	Automatic tripping device	Hydraulic-magnetic Fixed ampere rating and instantaneous			Thermal, magnetic Fixed ampere rating and instantaneous			Thermal, magnetic Fixed ampere rating and instantaneous		
	Rating (A) and Inst. (A)	10 110 ± 35 15 165 ± 52 20 220 ± 70 30 330 ± 105 40 440 ± 140 50 550 ± 175 60 660 ± 210			50 750 ± 150 60 900 ± 180 75 1125 ± 225 100 1500 ± 300			15 225 ± 45 20 300 ± 60 30 450 ± 90 40 600 ± 120 50 750 ± 150 60 900 ± 180 75 1125 ± 225 100 1500 ± 300		
Low-inst	Number of poles	-			2 3			2 3 4		
	Automatic tripping device	-			Thermal, magnetic Fixed ampere rating and instantaneous			Thermal, magnetic Fixed ampere rating and instantaneous		
	Rating (A) and Inst. (A)	-			50 300 ± 60 60 360 ± 72 75 450 ± 90 100 600 ± 120			15 90 ± 18 20 120 ± 24 30 180 ± 36 40 240 ± 48 50 300 ± 60 60 360 ± 72 75 450 ± 90 100 600 ± 120		
Generator	Number of poles	-			-			-		
	Automatic tripping device	-			-			-		
	Rating (A) and Inst. (A)	-			-			-		
Mag-Only	Number of poles	2 3 4			2 3			2 3 4		
	Automatic tripping device	Magnetic Fixed ampere rating and instantaneous			Magnetic Fixed ampere rating and instantaneous			Magnetic Fixed ampere rating and instantaneous		
	Rating (A) and Inst. (A)	10 100 ± 20 15 150 ± 30 20 200 ± 40 30 300 ± 60 40 400 ± 80 50 500 ± 100 60 600 ± 120			50 500 ± 100 60 600 ± 120 75 750 ± 150 100 1000 ± 200			15 150 ± 30 20 200 ± 40 30 300 ± 60 40 400 ± 80 50 500 ± 100 60 600 ± 120 75 750 ± 150 100 1000 ± 200		

Frame (A)	100	50	100	
Type	NF100-CP T/A	NF50-HRP	NF100-SP T/A	
Rated current In (A)	15 ~ 20, 20 ~ 25, 25 ~ 40 40 ~ 63, 63 ~ 80, 80 ~ 100	15, 20, 30, 40, 50	15 ~ 20, 20 ~ 25, 25 ~ 40 40 ~ 63, 63 ~ 80, 80 ~ 100	
Rated insulation voltage Ui (V) AC	600	690	690	
AC Breaking capacity (kA rms) IEC60947-2 Icu/Ics	690V	–	–	
	500V	7.5/4	15/8	
	440V	10/5	25/13	
	400V	10/5	30/15	
	230V	25/13	85/43	50/25
Standard	Number of poles	2 3	2 3 4	
	Automatic tripping device	Thermal, magnetic Adjustable ampere rating and fixed instantaneous	Thermal, magnetic Fixed ampere rating and instantaneous	Thermal, magnetic Adjustable ampere rating and fixed instantaneous
	Rating (A) and Inst. (A)	15 ~ 20 225 ± 45 20 ~ 25 300 ± 60 25 ~ 40 375 ± 75 40 ~ 63 600 ± 120 63 ~ 80 945 ± 189 80 ~ 100 1200 ± 240	15 225 ± 45 20 300 ± 60 30 450 ± 90 40 600 ± 120 50 750 ± 150	15 ~ 20 225 ± 45 20 ~ 25 300 ± 60 25 ~ 40 375 ± 75 40 ~ 63 600 ± 120 63 ~ 80 945 ± 189 80 ~ 100 1200 ± 240
Low-inst	Number of poles	–	–	
	Automatic tripping device	–	–	
	Rating (A) and Inst. (A)	–	–	
Generator	Number of poles	–	–	
	Automatic tripping device	–	–	
	Rating (A) and Inst. (A)	–	–	
Mag-Only	Number of poles	–	2 3	
	Automatic tripping device	–	Magnetic Fixed ampere rating and instantaneous	
	Rating (A) and Inst. (A)	–	15 150 ± 30 20 200 ± 40 30 300 ± 60 40 400 ± 80 50 500 ± 100	

Frame (A)		100											
Type		NF100-HP				NF100-HP T/A				NF100-RP			
Rated current In (A)		15, 20, 30, 40, 50, 60, 75, 100				15 ~ 20, 20 ~ 25, 25 ~ 40 40 ~ 63, 63 ~ 80, 80 ~ 100				15, 20, 30, 40, 50, 60, 75, 100			
Rated insulation voltage Ui (V) AC		690				690				690			
AC Breaking capacity (kA rms) IEC60947-2 Icu/Ics	690V	5/3				- (5/3) *				-			
	500V	30/15				30/15				42/42			
	440V	50/25				50/25				125/125			
	400V	50/25				50/25				125/125			
	230V	100/50				100/50				125/125			
Standard	Number of poles	2 3 4				2 3 4				2 3			
	Automatic tripping device	Thermal, magnetic Fixed ampere rating and instantaneous				Thermal, magnetic Adjustable ampere rating and fixed instantaneous				Thermal, magnetic Fixed ampere rating and instantaneous			
	Rating (A) and Inst. (A)	15 225 ± 45 20 300 ± 60 30 450 ± 90 40 600 ± 120 50 750 ± 150 60 900 ± 180 75 1125 ± 225 100 1500 ± 300				15 ~ 20 225 ± 45 20 ~ 25 300 ± 60 25 ~ 40 375 ± 75 40 ~ 63 600 ± 120 63 ~ 80 945 ± 189 80 ~ 100 1200 ± 240				15 225 ± 45 20 300 ± 60 30 450 ± 90 40 600 ± 120 50 750 ± 150 60 900 ± 180 75 1125 ± 225 100 1500 ± 300			
Low-inst	Number of poles	-				-				-			
	Automatic tripping device	-				-				-			
	Rating (A) and Inst. (A)	-				-				-			
Generator	Number of poles	-				-				-			
	Automatic tripping device	-				-				-			
	Rating (A) and Inst. (A)	-				-				-			
Mag-Only	Number of poles	2 3 4				-				-			
	Automatic tripping device	Magnetic Fixed ampere rating and instantaneous				-				-			
	Rating (A) and Inst. (A)	15 150 ± 30 20 200 ± 40 30 300 ± 60 40 400 ± 80 50 500 ± 100 60 600 ± 120 75 750 ± 150 100 1000 ± 200				-				-			

* To be agreed soon.

Frame (A)		100					
Type		NF100-UP		NF100-SEP		NF100-HEP	
Rated current In (A)		15, 20, 30, 40, 50, 60, 75, 100		30 ~ 50, 60 ~ 100		30 ~ 50, 60 ~ 100	
Rated insulation voltage Ui (V) AC		690		690		690	
AC Breaking capacity (kA rms) IEC60947-2 Icu/Ics	690V	10/5		-		5/3	
	500V	200/200		15/8		30/15	
	440V	200/200		25/13		50/25	
	400V	200/200		30/15		50/25	
	230V	200/200		50/25		100/50	
Standard	Number of poles	2 3 4		3 4		3 4	
	Automatic tripping device	Thermal, magnetic Fixed ampere rating and instantaneous		Electronic trip relay Adjustable ampere rating Adjustable long time delay operating time, short time delay pick up, and instantaneous		Electronic trip relay Adjustable ampere rating Adjustable long time delay operating time, short time delay pick up, and instantaneous	
	Rating (A) and Inst. (A)	15 225 ± 45 20 300 ± 60 30 450 ± 90 40 600 ± 120 50 750 ± 150 60 900 ± 180 75 1125 ± 225 100 1500 ± 300		Short time delay pick up current Variation is within ±15% of setting current 2 to 10 Ir 30 60-75-90-105-120-150-180-210-240-300 40 80-100-120-140-160-200-240-280-320-400 50 100-125-150-175-200-250-300-350-400-500 60 120-150-180-210-240-300-360-420-480-600 75 150-187.5-225-262.5-300-375-450-525-600-750 100 200-250-300-350-400-500-600-700-800-1000 Instantaneous pick up current Variation is within ±15% of setting current 4 In ~ 16 In 30 ~ 50 200 ~ 800 60 ~ 100 400 ~ 1600		Short time delay pick up current Variation is within ±15% of setting current 2 to 10 Ir 30 60-75-90-105-120-150-180-210-240-300 40 80-100-120-140-160-200-240-280-320-400 50 100-125-150-175-200-250-300-350-400-500 60 120-150-180-210-240-300-360-420-480-600 75 150-187.5-225-262.5-300-375-450-525-600-750 100 200-250-300-350-400-500-600-700-800-1000 Instantaneous pick up current Variation is within ±15% of setting current 4 In ~ 16 In 30 ~ 50 200 ~ 800 60 ~ 100 400 ~ 1600	
	Number of poles	-		-		-	
Automatic tripping device	-		-		-		
Rating (A) and Inst. (A)	-		-		-		
Generator	Number of poles	-		3		3	
	Automatic tripping device	-		Electronic trip relay Adjustable ampere rating Adjustable long time delay operating time, short time delay pick up, and instantaneous		Electronic trip relay Adjustable ampere rating Adjustable long time delay operating time, short time delay pick up, and instantaneous	
	Rating (A) and Inst. (A)	-		Rating: 30 ~ 50A, 60 ~ 100A Inst. : Operating characteristics must be adjusted as follows. STD ≤ 3 (Is setting) LTD : minimum setting (TL = 12sec setting)		Rating: 30 ~ 50A, 60 ~ 100A Inst. : Operating characteristics must be adjusted as follows. STD ≤ 3 (Is setting) LTD : minimum setting (TL = 12sec setting)	
Mag-Only	Number of poles	-		-		-	
	Automatic tripping device	-		-		-	
	Rating (A) and Inst. (A)	-		-		-	

Frame (A)		160								
Type		NF160-SP			NF160-SP T/A			NF160-HP		
Rated current In (A)		125, 150, 160			100 ~ 125, 125 ~ 160			125, 150, 160		
Rated insulation voltage Ui (V) AC		690			690			690		
AC Breaking capacity (kA rms) IEC60947-2 Icu/Ics	690V	-			-			5/3		
	500V	15/8			15/8			30/8		
	440V	25/13			25/13			50/13		
	400V	30/15			30/15			50/13		
	230V	50/25			50/25			100/25		
Standard	Number of poles	2 3 4			2 3 4			2 3 4		
	Automatic tripping device	Thermal, magnetic Fixed ampere rating and instantaneous			Thermal, magnetic Adjustable ampere rating and fixed instantaneous			Thermal, magnetic Fixed ampere rating and instantaneous		
	Rating (A) and Inst. (A)	125 1750 ± 350 150 2100 ± 420 160 2240 ± 448			100 ~ 125 1400 ± 280 125 ~ 160 1400 ± 280			125 1750 ± 350 150 2100 ± 420 160 2240 ± 448		
Low-inst	Number of poles	-			-			-		
	Automatic tripping device	-			-			-		
	Rating (A) and Inst. (A)	-			-			-		
Generator	Number of poles	-			-			-		
	Automatic tripping device	-			-			-		
	Rating (A) and Inst. (A)	-			-			-		
Mag-Only	Number of poles	2 3 4			-			2 3 4		
	Automatic tripping device	Magnetic Fixed ampere rating and instantaneous			-			Magnetic Fixed ampere rating and instantaneous		
	Rating (A) and Inst. (A)	125 1250 ± 250 160 1600 ± 320			-			125 1250 ± 250 160 1600 ± 320		

Frame (A)		160			250					
Type		NF160-HP T/A			NF250-CP			NF250-CP T/A		
Rated current In (A)		100 ~ 125, 125 ~ 160			125, 150, 175, 200, 225, 250			100 ~ 125, 125 ~ 160 150 ~ 200, 200 ~ 250		
Rated insulation voltage Ui (V) AC		690			600			600		
AC Breaking capacity (kA rms) IEC60947-2 Icu/Ics	690V	- (10/5) *			-			-		
	500V	30/8 (30/15) *			10/5			10/5		
	440V	50/13 (50/25) *			15/8			15/8		
	400V	50/13 (50/25) *			18/9			18/9		
	230V	100/25 (100/50) *			30/15			30/15		
Standard	Number of poles	2 3 4			2 3			2 3		
	Automatic tripping device	Thermal, magnetic Adjustable ampere rating and fixed instantaneous			Thermal, magnetic Fixed ampere rating and instantaneous			Thermal, magnetic Adjustable ampere rating and fixed instantaneous		
	Rating (A) and Inst. (A)	100 ~ 125 1400 ± 280 125 ~ 160 1400 ± 280			125 1750 ± 350 150 2100 ± 420 175 2450 ± 490 200 2800 ± 560 225 3150 ± 630 250 2500 ± 500			100 ~ 125 1400 ± 280 125 ~ 160 1400 ± 280 150 ~ 200 2100 ± 420 200 ~ 250 2500 ± 500		
Low-inst	Number of poles	-			2 3			-		
	Automatic tripping device	-			Thermal, magnetic Fixed ampere rating and instantaneous			-		
	Rating (A) and Inst. (A)	-			6 In 4 In 125 750 ± 150 500 ± 100 150 900 ± 180 600 ± 120 175 1050 ± 210 700 ± 140 200 1200 ± 240 800 ± 160 225 1350 ± 270 900 ± 180 250 1500 ± 300 1000 ± 200			-		
Generator	Number of poles	-			-			-		
	Automatic tripping device	-			-			-		
	Rating (A) and Inst. (A)	-			-			-		
Mag-Only	Number of poles	-			2 3			-		
	Automatic tripping device	-			Magnetic Fixed ampere rating and instantaneous			-		
	Rating (A) and Inst. (A)	-			125 1250 ± 250 150 1500 ± 300 175 1750 ± 350 200 2000 ± 400 225 2250 ± 450 250 2250 ± 450			-		

* To be agreed soon.

Frame (A)		250					
Type		NF250-SP		NF250-SP T/A		NF250-HP	
Rated current In (A)		125, 150, 175, 200, 225, 250		100 ~ 125, 125 ~ 160 150 ~ 200, 200 ~ 250		125, 150, 175, 200, 225, 250	
Rated insulation voltage Ui (V) AC		690		690		690	
AC Breaking capacity (kA rms) IEC60947-2 Icu/Ics	690V	-		-		5/3	
	500V	15/8		-		30/8	
	440V	25/13		25/20		50/13	
	400V	30/15		30/22		50/13	
	230V	50/25		50/42		100/25	
Standard	Number of poles	2 3 4		2 3 4		2 3 4	
	Automatic tripping device	Thermal, magnetic Fixed ampere rating and instantaneous		Thermal, magnetic Adjustable ampere rating and fixed instantaneous		Thermal, magnetic Fixed ampere rating and instantaneous	
	Rating (A) and Inst. (A)	125 1750 ± 350 150 2100 ± 420 175 2450 ± 490 200 2800 ± 560 225 3150 ± 630 250 2500 ± 500		100 ~ 125 1400 ± 280 125 ~ 160 1400 ± 280 150 ~ 200 2100 ± 420 200 ~ 250 2500 ± 500		125 1750 ± 350 150 2100 ± 420 175 2450 ± 490 200 2800 ± 560 225 3150 ± 630 250 2500 ± 500	
Low-inst	Number of poles	2 3 4		-		-	
	Automatic tripping device	Thermal, magnetic Fixed ampere rating and instantaneous		-		-	
	Rating (A) and Inst. (A)	6 In 4 In 125 750 ± 150 500 ± 100 150 900 ± 180 600 ± 120 175 1050 ± 210 700 ± 140 200 1200 ± 240 800 ± 160 225 1350 ± 270 900 ± 180 250 1500 ± 300 1000 ± 200		-		-	
Generator	Number of poles	-		-		-	
	Automatic tripping device	-		-		-	
	Rating (A) and Inst. (A)	-		-		-	
Mag-Only	Number of poles	2 3 4		-		2 3 4	
	Automatic tripping device	Magnetic Fixed ampere rating and instantaneous		-		Magnetic Fixed ampere rating and instantaneous	
	Rating (A) and Inst. (A)	125 1250 ± 250 150 1500 ± 300 175 1750 ± 350 200 2000 ± 400 225 2250 ± 450 250 2250 ± 450		-		125 1250 ± 250 150 1500 ± 300 175 1750 ± 350 200 2000 ± 400 225 2250 ± 450 250 2250 ± 450	

Frame (A)	250			225			
Type	NF250-HP T/A			NF225-RP		NF225-UP	
Rated current In (A)	100 ~ 125, 125 ~ 160 150 ~ 200, 200 ~ 250			125, 150, 175, 200, 225		125, 150, 175, 200, 225	
Rated insulation voltage Ui (V) AC	690			690		690	
AC Breaking capacity (kA rms) IEC60947-2 Icu/Ics	690V	- (10/5) *			-		10/5
	500V	30/8 (30/15) *			42/42		200/200
	440V	50/13 (50/25) *			125/125		200/200
	400V	50/13 (50/25) *			125/125		200/200
	230V	100/25 (100/50) *			125/125		200/200
Standard	Number of poles	2 3 4			2 3		2 3 4
	Automatic tripping device	Thermal, magnetic Adjustable ampere rating and fixed instantaneous			Thermal, magnetic Fixed ampere rating and instantaneous		Thermal, magnetic Fixed ampere rating and instantaneous
	Rating (A) and Inst. (A)	100 ~ 125 1400 ± 280 125 ~ 160 1400 ± 280 150 ~ 200 2100 ± 420 200 ~ 250 2500 ± 500			125 1750 ± 350 150 2100 ± 420 175 2450 ± 490 200 2800 ± 560 225 3150 ± 630		125 1750 ± 350 150 2100 ± 420 175 2450 ± 490 200 2800 ± 560 225 3150 ± 630
Low-inst	Number of poles	-			-		-
	Automatic tripping device	-			-		-
	Rating (A) and Inst. (A)	-			-		-
Generator	Number of poles	-			-		-
	Automatic tripping device	-			-		-
	Rating (A) and Inst. (A)	-			-		-
Mag-Only	Number of poles	-			-		-
	Automatic tripping device	-			-		-
	Rating (A) and Inst. (A)	-			-		-

* To be agreed soon.

Frame (A)		250	
Type		NF250-SEP	NF250-HEP
Rated current In (A)		125-250	125-250
Rated insulation voltage Ui (V) AC		690	690
AC Breaking capacity (kA rms) IEC60947-2 Icu/Ics	690V	–	5/3
	500V	15/8	30/8
	440V	25/13	50/13
	400V	30/15	50/13
	230V	50/25	100/25
Standard	Number of poles	3 4	3 4
	Automatic tripping device	Electronic trip relay Adjustable ampere rating Adjustable long time delay operating time, short time delay pick up, and instantaneous	Electronic trip relay Adjustable ampere rating Adjustable long time delay operating time, short time delay pick up, and instantaneous
	Rating (A) and Inst. (A)	Short time delay pick up current Variation is within $\pm 15\%$ of setting current 2 to 10 Ir 125 250-312.5-375-437.5-500-625-750-875-1000-1250 150 300-375-450-525-600-750-900-1050-1200-1500 175 350-437.5-525-612.5-700-875-1050-1225-1400-1750 200 400-500-600-700-800-1000-1200-1400-1600-2000 225 450-562.5-675-787.5-900-1125-1350-1575-1800-2250 250 500-625-750-875-1000-1250-1500-1750-2000-2500 Instantaneous pick up current Variation is within $\pm 15\%$ of setting current 4 ~ 14 In 125 ~ 250 1000 ~ 3500	Short time delay pick up current Variation is within $\pm 15\%$ of setting current 2 to 10 Ir 125 250-312.5-375-437.5-500-625-750-875-1000-1250 150 300-375-450-525-600-750-900-1050-1200-1500 175 350-437.5-525-612.5-700-875-1050-1225-1400-1750 200 400-500-600-700-800-1000-1200-1400-1600-2000 225 450-562.5-675-787.5-900-1125-1350-1575-1800-2250 250 500-625-750-875-1000-1250-1500-1750-2000-2500 Instantaneous pick up current Variation is within $\pm 15\%$ of setting current 4 ~ 14 In 125 ~ 250 1000 ~ 3500
Low-inst	Number of poles	–	–
	Automatic tripping device	–	–
	Rating (A) and Inst. (A)	–	–
Generator	Number of poles	3	3
	Automatic tripping device	Electronic trip relay Adjustable ampere rating Adjustable long time delay operating time, short time delay pick up, and instantaneous	Electronic trip relay Adjustable ampere rating Adjustable long time delay operating time, short time delay pick up, and instantaneous
	Rating (A) and Inst. (A)	Rating: 125 ~ 250A Inst. : Operating characteristics must be adjusted as follows. STD ≤ 3 (Is setting) LTD : minimum setting (TL = 12sec setting)	Rating: 125 ~ 250A Inst. : Operating characteristics must be adjusted as follows. STD ≤ 3 (Is setting) LTD : minimum setting (TL = 12sec setting)
Mag-Only	Number of poles	–	–
	Automatic tripping device	–	–
	Rating (A) and Inst. (A)	–	–

Frame (A)		400A					
Type		NF400-CP		NF400-SP		NF400-SEP	
Rated current In (A)		250, 300, 350, 400		250, 300, 350, 400		200 ~ 400 adjustable	
Rated insulation voltage Ui (V) AC		600		690		690	
AC Breaking capacity (kA rms) IEC60947-2 Icu/Ics	690V	-		10/10		10/10	
	500V	15/8		30/30		30/30	
	440V	25/13		42/42		42/42	
	400V	36/18		45/45		45/45	
	230V	50/25		85/85		85/85	
Standard	Number of poles	2 3		2 3 4		3 4	
	Automatic tripping device	Thermal, magnetic Fixed ampere rating and instantaneous		Thermal, magnetic Fixed ampere rating and instantaneous		Electronic trip relay Adjustable ampere rating Adjustable long time delay operating time, short time delay pick up and instantaneous	
	Rating (A) and Inst. (A)	250 2500 ± 500 300 3000 ± 600 350 3500 ± 700 400 4000 ± 800		250 3500 ± 700 300 4200 ± 840 350 4900 ± 980 400 5600 ± 1120		Short time delay pick up current Variation is within ±15% of setting current 2 to 10 Ir 200 400-500-600-700-800-1000-1200-1400-1600-2000 225 450-562.5-675-787.5-900-1125-1200-1500-1800-1350-1575-1800-2250 250 500-625-750-875-1000-1250-1500-1750-2000-2500 300 600-750-900-1050-1200-1500-1800-2100-2400-3000 350 700-875-1050-1225-1400-1750-2100-2450-2800-3500 400 800-1000-1200-1400-1600-2000-2400-2800-3200-4000 Instantaneous pick up current Variation is within ±15% of setting current 4 In ~ 16 In 1600 ~ 6400	
Low-inst	Number of poles	2 3		-		-	
	Automatic tripping device	Thermal, magnetic Fixed ampere rating and instantaneous		-		-	
	Rating (A) and Inst. (A)	6 In 4 In 250 1500±300 1000±200 300 1800±360 1200±240 350 2100±420 1400±280 400 2400±480 1600±320		-		-	
Generator	Number of poles	-		-		-	
	Automatic tripping device	-		-		-	
	Rating (A) and Inst. (A)	-		-		-	
Mag-Only (Inst trip only)	Number of poles	2 3		2 3 4		-	
	Automatic tripping device	Magnetic Fixed ampere rating and instantaneous		Magnetic Fixed ampere rating and instantaneous		-	
	Rating (A) and Inst. (A)	250 2500 ± 500 300 3000 ± 600 350 3500 ± 700 400 4000 ± 800		250 2500 ± 500 300 3000 ± 600 350 3500 ± 700 400 4000 ± 800		-	

Frame (A)		400A					
Type		NF400-HEP		NF400-REP		NF400-UEP	
Rated current In (A)		200 ~ 400 adjustable		200 ~ 400 adjustable		200 ~ 400 adjustable	
Rated insulation voltage Ui (V) AC		690		690		690	
AC Breaking capacity (kA rms) IEC60947-2 Icu/Ics	690V	10/10		15/10		35/35	
	500V	50/50		70/35		170/170	
	440V	65/65		125/63		200/200	
	400V	70/70		125/63		200/200	
	230V	100/100		150/75		200/200	
Standard	Number of poles	3 4		3		3 4	
	Automatic tripping device	Electronic trip relay Adjustable ampere rating Adjustable long time delay operating time, short time delay pick up and instantaneous		Electronic trip relay Adjustable ampere rating Adjustable long time delay operating time, short time delay pick up and instantaneous		Electronic trip relay Adjustable ampere rating Adjustable long time delay operating time, short time delay pick up and instantaneous	
	Rating (A) and Inst. (A)	Short time delay pick up current Variation is within $\pm 15\%$ of setting current 2 to 10 Ir 200 400-500-600-700-800-1000-1200-1400-1600-2000 225 450-562.5-675-787.5-900-1125-1200-1500-1800-1350-1575-1800-2250 250 500-625-750-875-1000-1250-1500-1750-2000-2500 300 600-750-900-1050-1200-1500-1800-2100-2400-3000 350 700-875-1050-1225-1400-1750-2100-2450-2800-3500 400 800-1000-1200-1400-1600-2000-2400-2800-3200-4000 Instantaneous pick up current Variation is within $\pm 15\%$ of setting current 4 In ~ 16 In 1600 ~ 6400		Short time delay pick up current Variation is within $\pm 15\%$ of setting current 2 to 10 Ir 200 400-500-600-700-800-1000-1200-1400-1600-2000 225 450-562.5-675-787.5-900-1125-1200-1500-1800-1350-1575-1800-2250 250 500-625-750-875-1000-1250-1500-1750-2000-2500 300 600-750-900-1050-1200-1500-1800-2100-2400-3000 350 700-875-1050-1225-1400-1750-2100-2450-2800-3500 400 800-1000-1200-1400-1600-2000-2400-2800-3200-4000 Instantaneous pick up current Variation is within $\pm 15\%$ of setting current 4 In ~ 16 In 1600 ~ 6400		Short time delay pick up current Variation is within $\pm 15\%$ of setting current 2 to 10 Ir 200 400-500-600-700-800-1000-1200-1400-1600-2000 225 450-562.5-675-787.5-900-1125-1200-1500-1800-1350-1575-1800-2250 250 500-625-750-875-1000-1250-1500-1750-2000-2500 300 600-750-900-1050-1200-1500-1800-2100-2400-3000 350 700-875-1050-1225-1400-1750-2100-2450-2800-3500 400 800-1000-1200-1400-1600-2000-2400-2800-3200-4000 Instantaneous pick up current Variation is within $\pm 15\%$ of setting current 4 In ~ 16 In 1600 ~ 6400	
Low-inst	Number of poles	-		-		-	
	Automatic tripping device	-		-		-	
	Rating (A) and Inst. (A)	-		-		-	
Generator	Number of poles	-		-		-	
	Automatic tripping device	-		-		-	
	Rating (A) and Inst. (A)	-		-		-	
Mag-Only (Inst trip only)	Number of poles	-		-		-	
	Automatic tripping device	-		-		-	
	Rating (A) and Inst. (A)	-		-		-	

Frame (A)		630A					
Type		NF630-CP		NF630-SP		NF630-SEP	
Rated current In (A)		500, 600, 630		500, 600, 630		300 ~ 630 adjustable	
Rated insulation voltage Ui (V) AC		600		690		690	
AC Breaking capacity (kA rms) IEC60947-2 Icu/Ics	690V	-		10/10		10/10	
	500V	18/9		30/30		30/30	
	440V	36/18		42/42		42/42	
	400V	36/18		45/45		45/45	
	230V	50/25		85/85		85/85	
Standard	Number of poles	2 3		2 3 4		3 4	
	Automatic tripping device	Thermal, magnetic Fixed ampere rating and instantaneous		Thermal, magnetic adjustable ampere rating and fixed instantaneous		Electronic trip relay Adjustable ampere rating Adjustable long time delay operating time, short time delay pick up and instantaneous	
	Rating (A) and Inst. (A)	500 5000 ± 1000 600 6000 ± 1200 630 6300 ± 1260		500 Lo 2500 ± 500 2 4000 3 5500 Hi 7000 ± 1400 600 Lo 3000 ± 600 2 4800 3 6600 Hi 8400 ± 1680 630 Lo 3150 ± 630 2 5040 3 6930 Hi 8820 ± 1764		Short time delay pick up current Variation is within ±15% of setting current 2 to 10 Ir 300 600-750-900-1050-1200-1500-1800-2100-2400-3000 350 700-875-1050-1225-1400-1750-2100-2450-2800-3500 400 800-1000-1200-1400-1600-2000-2400-2800-3200-4000 500 1000-1250-1500-1750-2000-2500-3000-3500-4000-5000 600 1200-1500-1800-2100-2400-3000-3600-4200-4800-6000 630 1260-1575-1890-2205-2520-3150-3780-4410-5040-6300 Instantaneous pick up current Variation is within ±15% of setting current 4 In ~ 15 In 2520 ~ 9450	
Low-inst	Number of poles	-		-		-	
	Automatic tripping device	-		-		-	
	Rating (A) and Inst. (A)	-		-		-	
Generator	Number of poles	-		-		-	
	Automatic tripping device	-		-		-	
	Rating (A) and Inst. (A)	-		-		-	
Mag-Only (Inst trip only)	Number of poles	2 3		2 3 4		-	
	Automatic tripping device	Magnetic Fixed ampere rating and instantaneous		Thermal, magnetic adjustable ampere rating and fixed instantaneous		-	
	Rating (A) and Inst. (A)	500 5000 ± 1000 600 6000 ± 1200 630 6300 ± 1260		500 Lo 2000 ± 400 2 3000 3 4000 Hi 5000 ± 1000 600 Lo 2400 ± 480 2 3600 3 4800 Hi 6000 ± 1200 630 Lo 2520 ± 504 2 3780 3 5040 Hi 6300 ± 1260		-	

Frame (A)		630A		
Type		NF630-HEP	NF630-REP	NF630-UEP
Rated current In (A)		300 ~ 630 adjustable	300 ~ 630 adjustable	300 ~ 630 adjustable
Rated insulation voltage Ui (V) AC		690	690	690
AC Breaking capacity (kA rms) IEC60947-2 Icu/Ics	690V	15/15	20/15	35/35
	500V	50/50	70/35	170/170
	440V	65/65	125/63	200/200
	400V	70/70	125/63	200/200
	230V	100/100	150/75	200/200
Standard	Number of poles	3 4	3	3 4
	Automatic tripping device	Electronic trip relay Adjustable ampere rating Adjustable long time delay operating time, short time delay pick up and instantaneous	Electronic trip relay Adjustable ampere rating Adjustable long time delay operating time, short time delay pick up and instantaneous	Electronic trip relay Adjustable ampere rating Adjustable long time delay operating time, short time delay pick up and instantaneous
	Rating (A) and Inst. (A)	Short time delay pick up current Variation is within $\pm 15\%$ of setting current 2 to 10 Ir 300 600-750-900-1050-1200-1500-1800-2100-2400-3000 350 700-875-1050-1225-1400-1750-2100-2450-2800-3500 400 800-1000-1200-1400-1600-2000-2400-2800-3200-4000 500 1000-1250-1500-1750-2000-2500-3000-3500-4000-5000 600 1200-1500-1800-2100-2400-3000-3600-4200-4800-6000 630 1260-1575-1890-2205-2520-3150-3780-4410-5040-6300 Instantaneous pick up current Variation is within $\pm 15\%$ of setting current 4 In ~ 15 In 2520 ~ 9450	Short time delay pick up current Variation is within $\pm 15\%$ of setting current 2 to 10 Ir 300 600-750-900-1050-1200-1500-1800-2100-2400-3000 350 700-875-1050-1225-1400-1750-2100-2450-2800-3500 400 800-1000-1200-1400-1600-2000-2400-2800-3200-4000 500 1000-1250-1500-1750-2000-2500-3000-3500-4000-5000 600 1200-1500-1800-2100-2400-3000-3600-4200-4800-6000 630 1260-1575-1890-2205-2520-3150-3780-4410-5040-6300 Instantaneous pick up current Variation is within $\pm 15\%$ of setting current 4 In ~ 15 In 2520 ~ 9450	Short time delay pick up current Variation is within $\pm 15\%$ of setting current 2 to 10 Ir 300 600-750-900-1050-1200-1500-1800-2100-2400-3000 350 700-875-1050-1225-1400-1750-2100-2450-2800-3500 400 800-1000-1200-1400-1600-2000-2400-2800-3200-4000 500 1000-1250-1500-1750-2000-2500-3000-3500-4000-5000 600 1200-1500-1800-2100-2400-3000-3600-4200-4800-6000 630 1260-1575-1890-2205-2520-3150-3780-4410-5040-6300 Instantaneous pick up current Variation is within $\pm 15\%$ of setting current 4 In ~ 15 In 2520 ~ 9450
Low-inst	Number of poles	-	-	-
	Automatic tripping device	-	-	-
	Rating (A) and Inst. (A)	-	-	-
Generator	Number of poles	-	-	-
	Automatic tripping device	-	-	-
	Rating (A) and Inst. (A)	-	-	-
Mag-Only (Inst trip only)	Number of poles	-	-	-
	Automatic tripping device	-	-	-
	Rating (A) and Inst. (A)	-	-	-

Frame (A)		800A		
Type		NF800-CEP	NF800-SEP	NF800-HEP
Rated current In (A)		400 ~ 800 adjustable	400 ~ 800 adjustable	400 ~ 800 adjustable
Rated insulation voltage Ui (V) AC		600	690	690
AC Breaking capacity (kA rms) IEC60947-2 Icu/Ics	690V	–	10/10	15/15
	500V	18/9	30/30	50/50
	440V	36/18	42/42	65/65
	400V	36/18	45/45	70/70
	230V	50/25	85/85	100/100
Standard	Number of poles	3	3 4	3 4
	Automatic tripping device	Electronic trip relay Adjustable ampere rating Adjustable long time delay operating time, short time delay pick up and instantaneous	Electronic trip relay Adjustable ampere rating Adjustable long time delay operating time, short time delay pick up and instantaneous	Electronic trip relay Adjustable ampere rating Adjustable long time delay operating time, short time delay pick up and instantaneous
	Rating (A) and Inst. (A)	Short time delay pick up current Variation is within $\pm 15\%$ of setting current 2 to 10 Ir 400 800-1000-1200-1400- 1600-2000-2400-2800- 3200-4000 450 900-1150-1350-1575- 1800-2250-2700-3150- 3600-4500 500 1000-1250-1500-1750- 2000-2500-3000-3500- 4000-5000 600 1200-1500-1800-2100- 2400-3000-3600-4200- 4800-6000 700 1400-1750-2100-2450- 2800-3500-4200-4900- 5600-6300 800 1260-1575-1890-2205- 2520-3150-3780-4410- 5040-6300 Instantaneous pick up current Variation is within $\pm 15\%$ of setting current 4 In ~ 12 In 3200 ~ 9600	Short time delay pick up current Variation is within $\pm 15\%$ of setting current 2 to 10 Ir 400 800-1000-1200-1400- 1600-2000-2400-2800- 3200-4000 450 900-1150-1350-1575- 1800-2250-2700-3150- 3600-4500 500 1000-1250-1500-1750- 2000-2500-3000-3500- 4000-5000 600 1200-1500-1800-2100- 2400-3000-3600-4200- 4800-6000 700 1400-1750-2100-2450- 2800-3500-4200-4900- 5600-6300 800 1260-1575-1890-2205- 2520-3150-3780-4410- 5040-6300 Instantaneous pick up current Variation is within $\pm 15\%$ of setting current 4 In ~ 12 In 3200 ~ 9600	Short time delay pick up current Variation is within $\pm 15\%$ of setting current 2 to 10 Ir 400 800-1000-1200-1400- 1600-2000-2400-2800- 3200-4000 450 900-1150-1350-1575- 1800-2250-2700-3150- 3600-4500 500 1000-1250-1500-1750- 2000-2500-3000-3500- 4000-5000 600 1200-1500-1800-2100- 2400-3000-3600-4200- 4800-6000 700 1400-1750-2100-2450- 2800-3500-4200-4900- 5600-6300 800 1260-1575-1890-2205- 2520-3150-3780-4410- 5040-6300 Instantaneous pick up current Variation is within $\pm 15\%$ of setting current 4 In ~ 12 In 3200 ~ 9600
Low-inst	Number of poles	–	–	–
	Automatic tripping device	–	–	–
	Rating (A) and Inst. (A)	–	–	–
Generator	Number of poles	–	–	–
	Automatic tripping device	–	–	–
	Rating (A) and Inst. (A)	–	–	–
Mag-Only (Inst trip only)	Number of poles	–	3 4	–
	Automatic tripping device	–	Electronic trip relay Adjustable ampere rating, instantaneous pick up current	–
	Rating (A) and Inst. (A)	–	Instantaneous pick up current Variation is within $\pm 15\%$ of setting current 2 to 10 Ir	–

Frame (A)		800A	
Type		NF800-REP	NF800-UEP
Rated current In (A)		400 ~ 800 adjustable	400 ~ 800 adjustable
Rated insulation voltage Ui (V) AC		690	690
AC Breaking capacity (kA rms) IEC60947-2 Icu/Ics	690V	20/15	35/35
	500V	70/35	170/170
	440V	125/63	200/200
	400V	125/63	200/200
	230V	150/75	200/200
Standard	Number of poles	3	3 4
	Automatic tripping device	Electronic trip relay Adjustable ampere rating Adjustable long time delay operating time, short time delay pick up and instantaneous	Electronic trip relay Adjustable ampere rating Adjustable long time delay operating time, short time delay pick up and instantaneous
	Rating (A) and Inst. (A)	Short time delay pick up current Variation is within $\pm 15\%$ of setting current 2 to 10 Ir 400 800-1000-1200-1400- 1600-2000-2400-2800- 3200-4000 450 900-1150-1350-1575- 1800-2250-2700-3150- 3600-4500 500 1000-1250-1500-1750- 2000-2500-3000-3500- 4000-5000 600 1200-1500-1800-2100- 2400-3000-3600-4200- 4800-6000 700 1400-1750-2100-2450- 2800-3500-4200-4900- 5600-6300 800 1260-1575-1890-2205- 2520-3150-3780-4410- 5040-6300 Instantaneous pick up current Variation is within $\pm 15\%$ of setting current 4 In ~ 12 In 3200 ~ 9600	Short time delay pick up current Variation is within $\pm 15\%$ of setting current 2 to 10 Ir 400 800-1000-1200-1400- 1600-2000-2400-2800- 3200-4000 450 900-1150-1350-1575- 1800-2250-2700-3150- 3600-4500 500 1000-1250-1500-1750- 2000-2500-3000-3500- 4000-5000 600 1200-1500-1800-2100- 2400-3000-3600-4200- 4800-6000 700 1400-1750-2100-2450- 2800-3500-4200-4900- 5600-6300 800 1260-1575-1890-2205- 2520-3150-3780-4410- 5040-6300 Instantaneous pick up current Variation is within $\pm 15\%$ of setting current 4 In ~ 12 In 3200 ~ 9600
Low-inst	Number of poles	-	-
	Automatic tripping device	-	-
	Rating (A) and Inst. (A)	-	-
Generator	Number of poles	-	-
	Automatic tripping device	-	-
	Rating (A) and Inst. (A)	-	-
Mag-Only (Inst trip only)	Number of poles	-	-
	Automatic tripping device	-	-
	Rating (A) and Inst. (A)	-	-

Frame (A)		1000			
Type		NF1000-SS			
Rated current In (A)		500-600-700-800-900-1000			
Rated insulation voltage Ui (V) AC		690			
AC Breaking capacity (kA rms) IEC60947-2 Icu/Ics	690V	25/13			
	500V	65/33			
	440V	85/43			
	400V	85/43			
	230V	125/63			
Standard	Number of poles	3 4			
	Automatic tripping device	Solid-state Adjustable ampere rating Adjustable short time delay pick up Fixed instantaneous pick up			
	Rating (A) and Inst. (A)	Short time delay pick up current Variation is within $\pm 10\%$ of the setting current 5-7.5-10 In 500 2500-3750-5000 600 3000-4500-6000 700 3500-5250-7000 800 4000-6000-8000 900 4500-6750-9000 1000 5000-7500-10000 Instantaneous pick up current 20000 $+4000$ -2000			
Low-inst	Number of poles	3 4			
	Automatic tripping device	Solid-state Adjustable ampere rating Adjustable instantaneous pick up			
	Rating (A) and Inst. (A)	Variation is within $\pm 10\%$ of the setting current 5-7.5-10 In 3-4.5-6 In 2-3-4 In 500 2500-3750-5000 1500-2250-3000 1000-1500-2000 600 3000-4500-6000 1800-2700-3600 1200-1800-2400 700 3500-5250-7000 2100-3150-4200 1400-2100-2800 800 4000-6000-8000 2400-3600-4800 1600-2400-3200 900 4500-6750-9000 2700-4050-5400 1800-2700-3600 1000 5000-7500-10000 3000-4500-6000 2000-3000-4000			
Generator	Number of poles	3 4			
	Automatic tripping device	Solid-state Adjustable ampere rating Adjustable instantaneous pick up			
	Rating (A) and Inst. (A)	Variation is within $\pm 10\%$ of the setting current 3-4.5-6 In 2-3-4 In 500 1500-2250-3000 1000-1500-2000 600 1800-2700-3600 1200-1800-2400 700 2100-3150-4200 1400-2100-2800 800 2400-3600-4800 1600-2400-3200 900 2700-4050-5400 1800-2700-3600 1000 3000-4500-6000 2000-3000-4000			
Mag-Only (Inst trip only)	Number of poles	3 4			
	Automatic tripping device	Solid-state Adjustable ampere rating Adjustable instantaneous pick up			
	Rating (A) and Inst. (A)	Variation is within $\pm 10\%$ of the setting current 5-7.5-10 In 500 2500-3750-5000 600 3000-4500-6000 700 3500-5250-7000 800 4000-6000-8000 900 4500-6750-9000 1000 5000-7500-10000			

Frame (A)	1250			
Type	NF1250-SS			
Rated current In (A)	600-700-800-1000-1200-1250			
Rated insulation voltage Ui (V) AC	690			
AC Breaking capacity (kA rms) IEC60947-2 Icu/Ics	690V	25/13		
	500V	65/33		
	440V	85/43		
	400V	85/43		
	230V	125/63		
Standard	Number of poles	3 4		
	Automatic tripping device	Solid-state Adjustable ampere rating Adjustable short time delay pick up Fixed instantaneous pick up		
	Rating (A) and Inst. (A)	Short time delay pick up current Variation is within $\pm 10\%$ of the setting current 5-7.5-10 In 600 3000-4500-6000 700 3500-5250-7000 800 4000-6000-8000 1000 5000-7500-10000 1200 6000-9000-12000 1250 6250-9375-12500 Instantaneous pick up current 20000 +4000 -2000		
Low-inst	Number of poles	3 4		
	Automatic tripping device	Solid-state Adjustable ampere rating Adjustable instantaneous pick up		
	Rating (A) and Inst. (A)	Variation is within $\pm 10\%$ of the setting current 5-7.5-10 In 3-4.5-6 In 2-3-4 In 600 3000-4500-6000 1800-2700-3600 1200-1800-2400 700 3500-5250-7000 2100-3150-4200 1400-2100-2800 800 4000-6000-8000 2400-3600-4800 1600-2400-3200 1000 5000-7500-10000 3000-4500-6000 2000-3000-4000 1200 6000-9000-12000 3600-5400-7200 2400-3600-4800 1250 6250-9375-12500 3750-5625-7500 2500-3750-5000		
Generator	Number of poles	3 4		
	Automatic tripping device	Solid-state Adjustable ampere rating Adjustable instantaneous pick up		
	Rating (A) and Inst. (A)	Variation is within $\pm 10\%$ of the setting current 3-4.5-6 In 2-3-4 In 600 1800-2700-3600 1200-1800-2400 700 2100-3150-4200 1400-2100-2800 800 2400-3600-4800 1600-2400-3200 1000 3000-4500-6000 2000-3000-4000 1200 3600-5400-7200 2400-3600-4800 1250 3750-5625-7500 2500-3750-5000		
Mag-Only (Inst trip only)	Number of poles	3 4		
	Automatic tripping device	Solid-state Adjustable ampere rating Adjustable instantaneous pick up		
	Rating (A) and Inst. (A)	Variation is within $\pm 10\%$ of the setting current 5-7.5-10 In 600 3000-4500-6000 700 3500-5250-7000 800 4000-6000-8000 1000 5000-7500-10000 1200 6000-9000-12000 1250 6250-9375-12500		

Frame (A)		1250	
Type		NF1250-UR	
Rated current In (A)		600-700-800-1000-1200-1250	
Rated insulation voltage Ui (V) AC		690	
AC Breaking capacity (kA rms) IEC60947-2 Icu/Ics	690V	-	
	500V	85/42	
	440V	125/65	
	400V	125/65	
	240V	170/85	
Standard	Number of poles	3	4
	Automatic tripping device	Solid-state Adjustable ampere rating Adjustable short time delay pick up Fixed instantaneous pick up	
	Rating (A) and Inst. (A)	Short time delay pick up current Variation is within $\pm 10\%$ of the setting current 5-7.5-10 In 600 3000-4500-6000 700 3500-5250-7000 800 4000-6000-8000 1000 5000-7500-10000 1200 6000-9000-12000 1250 6250-9375-12500 Instantaneous pick up current 20000 +4000 -2000	
Low-inst	Number of poles	-	
	Automatic tripping device	-	
	Rating (A) and Inst. (A)	-	
Generator	Number of poles	-	
	Automatic tripping device	-	
	Rating (A) and Inst. (A)	-	
Mag-Only (Inst trip only)	Number of poles	-	
	Automatic tripping device	-	
	Rating (A) and Inst. (A)	-	

Frame (A)		1600		
Type		NF1600-SS		
Rated current In (A)		800-1000-1200-1400-1500-1600		
Rated insulation voltage Ui (V) AC		690		
AC Breaking capacity (kA rms) IEC60947-2 Icu/Ics	690V	25/13		
	500V	65/33		
	440V	85/43		
	400V	85/43		
	230V	125/63		
Standard	Number of poles	3 4		
	Automatic tripping device	Solid-state Adjustable ampere rating Adjustable short time delay pick up Fixed instantaneous pick up		
	Rating (A) and Inst. (A)	Short time delay pick up current Variation is within $\pm 10\%$ of the setting current 3-4.5-6 In 800 2400-3600-4800 1000 3000-4500-6000 1200 3600-5400-7200 1400 4200-6300-8400 1500 4500-6750-9000 1600 4800-7200-9600 Instantaneous pick up current 20000 +4000 -2000		
Low-inst	Number of poles	3 4		
	Automatic tripping device	Solid-state Adjustable ampere rating Adjustable instantaneous pick up		
	Rating (A) and Inst. (A)	Variation is within $\pm 10\%$ of the setting current 3-4.5-6 In 2-3-4 In 800 2400-3600-4800 1600-2400-3200 1000 3000-4500-6000 2000-3000-4000 1200 3600-5400-7200 2400-3600-4800 1400 4200-6300-8400 2800-4200-5600 1500 4500-6750-9000 3000-4500-6000 1600 4800-7200-9600 3200-4800-6400		
Generator	Number of poles	3 4		
	Automatic tripping device	Solid-state Adjustable ampere rating Adjustable instantaneous pick up		
	Rating (A) and Inst. (A)	Variation is within $\pm 10\%$ of the setting current 3-4.5-6 In 2-3-4 In 800 2400-3600-4800 1600-2400-3200 1000 3000-4500-6000 2000-3000-4000 1200 3600-5400-7200 2400-3600-4800 1400 4200-6300-8400 2800-4200-5600 1500 4500-6750-9000 3000-4500-6000 1600 4800-7200-9600 3200-4800-6400		
Mag-Only (Inst trip only)	Number of poles	3 4		
	Automatic tripping device	Solid-state Adjustable ampere rating Adjustable instantaneous pick up		
	Rating (A) and Inst. (A)	Variation is within $\pm 10\%$ of the setting current 3-4.5-6 In 800 2400-3600-4800 1000 3000-4500-6000 1200 3600-5400-7200 1400 4200-6300-8400 1500 4500-6750-9000 1600 4800-7200-9600		

Frame (A)		2000		2500
Type		NF2000-S	NFE2000-S	NF2500-S
Rated current In (A)		1800, 2000	1200-1400-1600-1800-2000	2500
Rated insulation voltage Ui (V) AC		600 * www.DataSheet4U.com	600	600 *
AC Interrupting capacity (kA rms) IEC157-1 P1/P2	600V	-	-	-
	500V	65/50	65/50	65/50
	415V	85/50	85/50	85/50
	380V	85/50	85/50	85/50
	240V	125/85	125/85	125/85
Standard	Number of poles	3 4	3 4	3
	Automatic tripping device	Thermal, adjustable-magnetic Fixed ampere rating and adjustable instantaneous	Solid-state Adjustable ampere rating, adjustable short time delay pick up and fixed instantaneous pick up	Thermal, adjustable-magnetic Fixed ampere rating and adjustable instantaneous
	Rating (A) and Inst. (A)	Variation is within ±10% of the Hi setting current Lo 1 2 3 1800 3200-4000-4800-5600-4 5 Hi 6400-7200-8000 Lo 1 2 3 2000 3200-4000-4800-5600-4 5 Hi 6400-7200-8000	Short time delay pick up current Variation is within ±10% of the setting current 3-4-5-6 In 1200 3600-5400-7200 1400 4200-6300-8400 1600 4800-7200-9600 1800 5400-8100-10800 2000 6000-9000-12000 Instantaneous pick up current 30000 ± 3000	Variation is within ±10% of the Hi setting current Lo 1 2 3 2500 4000-5000-6000-7000-4 5 Hi 8000-9000-10000
Low-inst	Number of poles	-	-	-
	Automatic tripping device	-	-	-
	Rating (A) and Inst. (A)	-	-	-
Generator	Number of poles	-	-	-
	Automatic tripping device	-	-	-
	Rating (A) and Inst. (A)	-	-	-
Mag-Only	Number of poles	3 4	-	3
	Automatic tripping device	Adjustable-magnetic Fixed ampere rating and adjustable instantaneous	-	Adjustable-magnetic Fixed ampere rating and adjustable instantaneous
	Rating (A) and Inst. (A)	Variation is within ±10% of the Hi setting current Lo 1 2 3 2000 3200-4000-4800-5600-4 5 Hi 6400-7200-8000	-	Variation is within ±10% of the Hi setting current Lo 1 2 3 2500 4000-5000-6000-7000-4 5 Hi 8000-9000-10000

*Specify frequency

www.DataSheet4U.com

Frame (A)		3000 (3200)																																															
Type		NF3200-S	NFE3000-S																																														
Rated current In (A)		2800, 3000, 3200	1800-2000-2500-3000																																														
Rated insulation voltage Ui (V) AC		600 *	600																																														
AC Interrupting capacity (kA rms) IEC157-1 P1/P2	600V	–	–																																														
	500V	65/50	65/50																																														
	415V	85/50	85/50																																														
	380V	85/50	85/50																																														
	240V	125/85	125/85																																														
Standard	Number of poles	3	3																																														
	Automatic tripping device	Thermal, adjustable-magnetic Fixed ampere rating and adjustable instantaneous	Solid-state Adjustable ampere rating, adjustable short time delay pick up and fixed instantaneous pick up																																														
	Rating (A) and Inst. (A)	Variation is within $\pm 10\%$ of the Hi setting current <table border="0"> <tr> <td></td> <td>Lo</td> <td>1</td> <td>2</td> <td>3</td> <td>4</td> <td>5</td> <td>Hi</td> </tr> <tr> <td>2800</td> <td>5000-6600-8300-10000-11600-13300-15000</td> <td></td> <td></td> <td></td> <td></td> <td></td> <td></td> </tr> <tr> <td>3000</td> <td>5000-6600-8300-10000-11600-13300-15000</td> <td></td> <td></td> <td></td> <td></td> <td></td> <td></td> </tr> <tr> <td>3200</td> <td>5000-6600-8300-10000-11600-13300-15000</td> <td></td> <td></td> <td></td> <td></td> <td></td> <td></td> </tr> </table>		Lo	1	2	3	4	5	Hi	2800	5000-6600-8300-10000-11600-13300-15000							3000	5000-6600-8300-10000-11600-13300-15000							3200	5000-6600-8300-10000-11600-13300-15000							Short time delay pick up current Variation is within $\pm 10\%$ of the setting current <table border="0"> <tr> <td></td> <td colspan="2">2-3-4 In</td> </tr> <tr> <td>1800</td> <td>3600-5400-7200</td> <td></td> </tr> <tr> <td>2000</td> <td>4000-6000-8000</td> <td></td> </tr> <tr> <td>2500</td> <td>5000-7500-10000</td> <td></td> </tr> <tr> <td>3000</td> <td>6000-9000-12000</td> <td></td> </tr> </table> Instantaneous pick up current 30000 \pm 3000		2-3-4 In		1800	3600-5400-7200		2000	4000-6000-8000		2500	5000-7500-10000		3000	6000-9000-12000
	Lo	1	2	3	4	5	Hi																																										
2800	5000-6600-8300-10000-11600-13300-15000																																																
3000	5000-6600-8300-10000-11600-13300-15000																																																
3200	5000-6600-8300-10000-11600-13300-15000																																																
	2-3-4 In																																																
1800	3600-5400-7200																																																
2000	4000-6000-8000																																																
2500	5000-7500-10000																																																
3000	6000-9000-12000																																																
Low-inst	Number of poles	–	–																																														
	Automatic tripping device	–	–																																														
	Rating (A) and Inst. (A)	–	–																																														
Generator	Number of poles	–	–																																														
	Automatic tripping device	–	–																																														
	Rating (A) and Inst. (A)	–	–																																														
Mag-Only	Number of poles	3	–																																														
	Automatic tripping device	Adjustable-magnetic Fixed ampere rating and adjustable instantaneous	–																																														
	Rating (A) and Inst. (A)	Variation is within $\pm 10\%$ of the Hi setting current <table border="0"> <tr> <td></td> <td>Lo</td> <td>1</td> <td>2</td> <td>3</td> <td>4</td> <td>5</td> <td>Hi</td> </tr> <tr> <td>3000</td> <td>5000-6600-8300-10000-11600-13300-15000</td> <td></td> <td></td> <td></td> <td></td> <td></td> <td></td> </tr> <tr> <td>3200</td> <td>5000-6600-8300-10000-11600-13300-15000</td> <td></td> <td></td> <td></td> <td></td> <td></td> <td></td> </tr> </table>		Lo	1	2	3	4	5	Hi	3000	5000-6600-8300-10000-11600-13300-15000							3200	5000-6600-8300-10000-11600-13300-15000							–																						
	Lo	1	2	3	4	5	Hi																																										
3000	5000-6600-8300-10000-11600-13300-15000																																																
3200	5000-6600-8300-10000-11600-13300-15000																																																

*Specify frequency

Frame (A)		4000		
Type		NF4000-S		NFE4000-S
Rated current In (A)		3600, 4000		2500-3000-3500-4000
Rated insulation voltage Ui (V) AC		600 *		600
AC Interrupting capacity (kA rms) IEC157-1 P1/P2	600V	-		-
	500V	65/50		65/50
	415V	85/50		85/50
	380V	85/50		85/50
	240V	125/85		125/85
Standard	Number of poles	3		3
	Automatic tripping device	Thermal, adjustable-magnetic Fixed ampere rating and adjustable instantaneous		Solid-state Adjustable ampere rating, adjustable short time delay pick up and fixed instantaneous pick up
	Rating (A) and Inst. (A)	Variation is within $\pm 10\%$ of the Hi setting current Lo 1 2 3 Hi 3600 8300-10000-11600-13300-15000 4000 8300-10000-11600-13300-15000		Short time delay pick up current Variation is within $\pm 10\%$ of the setting current 2-3-4 In 2500 5000-7500-10000 3000 6000-9000-12000 3500 7000-10500-14000 4000 8000-12000-16000 Instantaneous pick up current 35000 \pm 3500
Low-inst	Number of poles	-		-
	Automatic tripping device	-		-
	Rating (A) and Inst. (A)	-		-
Generator	Number of poles	-		-
	Automatic tripping device	-		-
	Rating (A) and Inst. (A)	-		-
Mag-Only	Number of poles	3		-
	Automatic tripping device	Adjustable-magnetic Fixed ampere rating and adjustable instantaneous		-
	Rating (A) and Inst. (A)	Variation is within $\pm 10\%$ of the Hi setting current Lo 1 2 3 Hi 4000 8300-10000-11600-13300-15000		-

*Specify frequency

6. PROTECTIVE CO-ORDINATION

6.1 General

Type of System

The primary purpose of a circuit protection system is to prevent damage to series connected equipment and to minimise the area and duration of power loss. The first consideration is whether an air circuit breaker or moulded case circuit breaker is most suitable.

The next is the type of system to be used. The three major types are: Fully Rated, Selective and Cascade Back-Up.

Fully Rated

This system is highly reliable, as all of the breakers are rated for the maximum fault level at the point of their installation. Discrimination (selective interruption) can be incorporated in some cases. The disadvantage is that high cost branch breakers may be necessary.

Selective-Interruption(Discrimination)

Selective Interruption requires that in the event of a fault, only the device directly before the fault will trip, and that other branch circuits of the same or higher level will not be affected. The range of selective Interruption of the main breaker varies considerably depending on the breaker used.

Cascade Back-Up Protection

This is an economical approach to the use of circuit breakers, whereby only the main (upstream) breaker has adequate interrupting capacity for the maximum available fault current. The mccb's downstream cannot handle this maximum fault current and rely on the opening of the upstream breaker for protection.

The advantage of the cascade back-up approach is that it facilitates the use of low cost, low fault level breakers downstream, thereby offering savings in both the cost and size of equipment.

As Mitsubishi mccb's have a very considerable current limiting effect, they can be used to provide this 'cascade back-up' protection for downstream circuit breakers.

6.2 Interrupting Capacity Consideration

Table 1 230VAC

3ph trans. capacity (kVA)	30 or less	50~75	100	150~300	500~1500	2000~3000							
1ph trans. capacity (kVA)	20 or less	30~50	75	100~150	200~500	-							
Interrupting capacity (kA)(sym)	2.5	5	10	15	25	30	35	50	85	100	125	170	200
Frame (A)	30	NF30-CS, NF30-SP											
	50-60	NF50-CP, NF60-CP	NF50-HP, NF60-HP	NF50-HRP									
	100	NF100-CP		NF100-SP, NF100-SEP		NF100-HP, NF100-HEP	NF100-RP	NF100-UP					
	160 250	NF250-CP			NF160-SP, NF250-SP, NF250-SEP	NF160-HP, NF250-HP, NF250-HEP	NF225-RP	NF225-UP					
	400	NF400-CP			NF400-SP, NF400-SEP		NF400-HP, NF400-HEP	NF400-RP	NF400-UP				
	630	NF630-CP				NF630-SP, NF630-SEP	NF630-HP, NF630-HEP	NF630-RP	NF630-UP				
	800	NF800-CP				NF800-SEP	NF800-HP, NF800-HEP	NF800-RP	NF800-UP				
	1000 4000	NF1000-SS~NF1600-SS, NF2000-S~NF4000-S NFE2000-S, NFE3000-S, NFE4000-S							NF1250-UR				

□ C Series ■ S Series

Table 2 440VAC

Trans. capacity (kVA)	30 or less	50~100	150~300	500~1000	1500~2000	2500~5000								
Interrupting capacity (kA)(sym)	1.5	2.5	7.5	10	15	18	25	30	35	50	65	85	125	200
Frame (A)	30	NF30-CS, NF30-SP												
	50-60	NF50-CP, NF60-CP	NF50-HP, NF60-HP	NF50-HRP										
	100	NF100-CP		NF100-SP, NF100-SEP	NF100-HP, NF100-HEP		NF100-RP	NF100-UP						
	160 250	NF250-CP			NF160-SP, NF250-SP, NF250-SEP	NF160-HP, NF250-HP, NF250-HEP	NF225-RP	NF225-UP						
	400	NF400-CP			NF400-SP, NF400-SEP		NF400-HP, NF400-HEP	NF400-RP	NF400-UP					
	630	NF630-CP				NF630-SP, NF630-SEP	NF630-HP, NF630-HEP	NF630-RP	NF630-UP					
	800	NF800-CP				NF800-SEP	NF800-HP, NF800-HEP	NF800-RP	NF800-UP					
	1000 4000	NF1000-SS~NF1600-SS, NF2000-S~NF4000-S NFE2000-S, NFE3000-S, NFE4000-S							NF1250-UR					

6.3 Selective-Interruption (Discrimination)

6.3.1 Selective-Interruption Combination

Following tables show combinations of main-circuit selective coordination breakers and branch breakers and the available selective tripping current at the setting points at the branch-circuits.

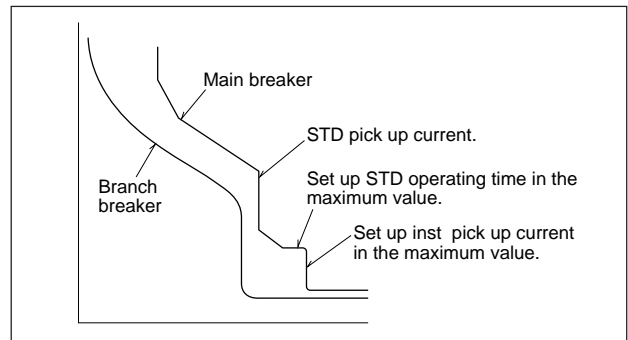
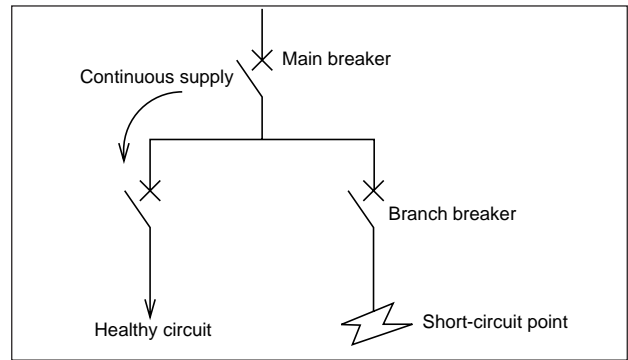

www.DataSheet4U.com

Selection Conditions

1. The main breaker rated current, STD operating time and INST pickup current are to be set to the maximum values.
2. When selecting the over-current range, also check the conformity using the other characteristic curves.

<How to see the table>

Example 1

All rated current of branch breaker, type NF30-SP can fully discriminate with all rated current of main breaker, type NF400-SEP up to the fault levels, 5kA that is the interrupting capacity of type NF30-SP.

230VAC

Main Breaker / Branch Breaker		Type	NF400-SEP					
		Icu(kA)	85					
Type	Icu (kA)	Rated current (A)	200	225	250	300	350	400
NF30-SP	5		Selective limit current					
			5					
		3						
		5						
		10						
		15						
		20						
		30						

Example 2

Some rated current of branch breaker, type NF160-SP can discriminate with some rated current of main breaker, type NF630-SEP as shown by a deep color up up to the fault levels, 10kA. 6 denotes that the short-time delay pick up current of the main breaker, type NF630-SEP is set at 6 X Ir notch or higher.

440VAC

Main Breaker / Branch Breaker		Type	NF630-SEP					
		Icu(kA)	50					
Type	Icu (kA)	Rated current (A)	300	350	400	500	600	630
NF160-SP	25		Selective limit current					
			10					
		125	6	6	5	4	3	3
		150	8	7	6	5	4	3.5
		160	8	7	6	5	4	4

Example 3

Some rated current of branch breaker, type NF100-CP having low-inst. trip can discriminate with some rated current of main breaker, type NF400-SEP as shown by a deep color up to the fault levels, 7.5kA. 6 denotes that the short time delay pick up current of the main breaker, type NF400-SEP is set at 6 X Ir notch or higher.

440VAC

Main Breaker / Branch Breaker		Type	NF400-SEP					
		Icu(kA)	50					
Type	Icu (kA)	Rated current (A)	200	225	250	300	350	400
NF100-CP	10		Selective limit current					
			7.5					
		50	5	5	4	3.5	3	2.5
		60	6	5	5	4	3.5	3
		75	7	7	6	5	4	3.5
		100	10	10	8	7	6	5

SELECTIVE-INTERRUPTION COMBINATIONS (DISCRIMINATION) 230VAC (Sym. kA)

Main Breaker Branch Breaker		Type	NF100-SEP						NF250-SEP					
		Icu(kA)	50						50					
Type	Icu(kA)	Rated current (A)	30	40	50	60	75	100	125	150	175	200	225	250
BH-D6 Type B	6		Selective limit current											
			0.8			1.6			3.5					
		6												
		10												
		13												
		16	2.5											
		20	3	2.5										
		25	3.5	3	2.5									
		32	5	3.5	3	2.5								
		40	6	5	3.5	3	2.5							
50	7	6	5	4	3	2.5								
63	10	7	6	5	4	3	2.5							
BH-D6 Type C	6		Selective limit current											
			0.8			1.6			3.5					
		6												
		10	3											
		13	3.5	3	2.5									
		16	5	3.5	3	2.5								
		20	6	4	3.5	3	2.5							
		25	7	5	4	3.5	3	2.5						
		32	10	7	6	5	4	3	2.5					
		40		8	7	6	5	3.5	3	2.5	2.5			
50		10	8	7	6	5	3.5	3	2.5	2.5				
63			10	10	7	6	5	3.5	3.5	3	2.5	2.5		
BH-D10 Type B	10		Selective limit current											
			0.8			1.6			3.5					
		6												
		10												
		13												
		16	2.5											
		20	3	2.5										
		25	3.5	3	2.5									
		32	5	3.5	3	2.5								
		40	6	5	3.5	3	2.5							
50	7	6	5	4	3	2.5								
63	10	7	6	5	4	3	2.5							
BH-D10 Type C	10		Selective limit current											
			0.8			1.6			3.5					
		6												
		10	3											
		13	3.5	3	2.5									
		16	5	3.5	3	2.5								
		20	6	4	3.5	3	2.5							
		25	7	5	4	3.5	3	2.5						
		32	10	7	6	5	4	3	2.5					
		40		8	7	6	5	3.5	3	2.5	2.5			
50		10	8	7	6	5	3.5	3	2.5	2.5				
63			10	10	7	6	5	3.5	3.5	3	2.5	2.5		

Icu: Rated breaking capacity

SELECTIVE-INTERRUPTION COMBINATIONS (DISCRIMINATION) 230VAC (Sym. kA)

Main Breaker		Type	NF100-SEP						NF250-SEP						NF400-SEP						NF630-SEP														
Branch Breaker		Icu(kA)	50						50						85						85														
Type	Icu(kA)	Rated current (A)	30	40	50	60	75	100	125	150	175	200	225	250	200	225	250	300	350	400	300	350	400	500	600	630									
NF30-SP	5		Selective limit current																																
		3	0.8						1.6						3.5						5						5								
		5																																	
		10	4	3	2.5																														
		15	6	5	3.5	3	2.5																												
		20	8	6	5	4	3	2.5																											
30		10	7	6	5	3.5	3	2.5																											
NF50-CP	5		Selective limit current																																
		10	0.8						1.6						3.5						5						5								
		15																																	
		20	4	3	2.5																														
		30	6	5	3.5	3	2.5																												
		40	8	6	5	4	3	2.5																											
50		10	7	6	5	3.5	3	2.5																											
NF50-HP	25		Selective limit current																																
		10	0.8						1.6						3.5						10						20								
		15																																	
		20	4	3	2.5																														
		30	6	5	3.5	3	2.5																												
		40	8	6	5	4	3	2.5																											
50		10	7	6	5	3.5	3	2.5																											
NF60-CP	5		Selective limit current																																
		60	1.6						3.5						5						5														
NF60-HP	25		Selective limit current																																
		60	1.6						3.5						10						20														
NF100-CP	25		Selective limit current																																
		50							3.5						7.5						10														
		60							8	7	6	5	5	4	5	5	4	3.5	3	2.5	2.5	2.5													
		75							10	8	7	6	5	5	6	5	5	4	3.5	3	3	2.5	2.5												
100										10	10	8	10	10	8	10	10	8	7	6	5	5	5	4	3	2.5	2.5								
NF100-SP	50		Selective limit current																																
		15							3.5						7.5						15														
		20							2.5																										
		30							3	2.5	2.5																								
		40							5	4	3.5	3	2.5	2.5	3	2.5	2.5																		
		50							6	5	5	4	3.5	3	4	3.5	3	2.5	2.5																
		60							8	7	6	5	5	4	5	5	4	3.5	3	2.5	2.5	2.5													
		75							10	8	7	6	5	5	6	5	5	4	3.5	3	3	2.5	2.5												
100										10	8	7	6	7	7	6	5	4	3.5	3	3	2.5	2.5												
NF100-SP T/A	50		Selective limit current																																
		15 ~ 20							3.5						7.5						15														
		20 ~ 25							2.5																										
		25 ~ 40							3	2.5	2.5																								
		40 ~ 63							4	3.5	3	2.5	2.5	2.5	2.5																				
		63 ~ 80							6	5	5	4	3.5	3	4	3.5	3	2.5	2.5																
80 ~ 100							10	8	7	6	6	5	6	6	5	4	3.5	3	3	2.5	2.5														
NF100-HP	100		Selective limit current																																
		15							3.5						10						25														
		20							2.5																										
		30							3	2.5	2.5																								
		40							5	4	3.5	3	2.5	2.5	3	3.5	2.5																		
		50							6	5	5	4	3.5	3	4	3.5	3	2.5	2.5																
		60							8	7	6	5	5	4	5	5	4	3.5	3	2.5	2.5	2.5													
		75							10	8	7	6	5	5	6	5	5	4	3.5	3	3	2.5	2.5												
100										10	8	7	6	7	7	6	5	4	3.5	3	3	2.5	2.5												
NF100-HP T/A	100		Selective limit current																																
		15 ~ 20							3.5						10						25														
		20 ~ 25							2.5																										
		25 ~ 40							3	2.5	2.5																								
		40 ~ 63							4	3.5	3	2.5	2.5	2.5	2.5																				
		63 ~ 80							6	5	5	4	3.5	3	4	3.5	3	2.5	2.5																
80 ~ 100							10	8	7	6	6	5	6	6	5	4	3.5	3	3	2.5	2.5														

Icu: Rated breaking capacity

Main Breaker		Type	NF800-CEP						NF800-SEP						NF1000-SS						NF1250-SS						NF1600-SS					
Branch Breaker		Icu(kA)	50						85						125						125						125					
Type	Icu(kA)	Rated current (A)	400	450	500	600	700	800	400	450	500	600	700	800	500	600	700	800	900	1000	600	700	800	1000	1200	1250	800	1000	1200	1400	1500	1600
NF30-SP	5		Selective limit current																													
		3	5						5						5						5											
		5																														
		10																														
		15																														
		20																														
NF50-CP	5		Selective limit current																													
		10	5						5						5						5											
		15																														
		20																														
		30																														
		40																														
NF50-HP	25		Selective limit current																													
		10	20						20						25						25											
		15																														
		20																														
		30																														
		40																														
NF60-CP	5		Selective limit current																													
		60	5						5						5						5											
NF60-HP	25		Selective limit current																													
		60	20						20						25						25											
NF100-CP	25		Selective limit current																													
		50	10						15						25						25											
		60	2.5						2.5																							
		75	3	2.5	2.5				3	2.5	2.5																					
		100	4	3.5	3	2.5	2.5		4	3.5	3	2.5	2.5																			
NF100-SP	50		Selective limit current																													
		15	15						15						50						50											
		20																														
		30																														
		40																														
		50																														
		60	2.5						2.5																							
75	3	2.5	2.5				3	2.5	2.5																							
NF100-SP T/A	50	80 ~ 100	4	3.5	3	2.5	2.5		4	3.5	3	2.5	2.5																			
		15 ~ 20																														
		20 ~ 25																														
		25 ~ 40																														
		40 ~ 63																														
		63 ~ 80	2.5	2.5					2.5	2.5																						
NF100-HP	100		Selective limit current																													
		15	25						25						100						100											
		20																														
		30																														
		40																														
		50																														
		60	2.5						2.5																							
75	3	2.5	2.5				3	2.5	2.5																							
NF100-HP T/A	100	80 ~ 100	4	3.5	3	2.5	2.5		4	3.5	3	2.5	2.5																			
		15 ~ 20																														
		20 ~ 25																														
		25 ~ 40																														
		40 ~ 63																														
		63 ~ 80	2.5	2.5					2.5	2.5																						

Icu: Rated breaking capacity

SELECTIVE-INTERRUPTION COMBINATIONS (DISCRIMINATION) 230VAC (Sym. kA)

Main Breaker		Type	NF100-SEP						NF250-SEP						NF400-SEP						NF630-SEP								
Branch Breaker		Icu(kA)	50						50						85						85								
Type	Icu(kA)	Rated current (A)	30	40	50	60	75	100	125	150	175	200	225	250	200	225	250	300	350	400	300	350	400	500	600	630			
NF100-SEP	50		Selective limit current																										
		30																											
		40								2.5																			
		50								3.5	3	2.5	2.5			2.5													
		60								5	3.5	3	3	2.5		3	2.5	2.5											
		75								6	5	3.5	3.5	3	2.5	3.5	3	2.5	2.5					2.5					
NF100-SEP	100		Selective limit current																										
		30																											
		40								2.5																			
		50								3.5	3	2.5	2.5			2.5													
		60								5	3.5	3	3	2.5		3	2.5	2.5											
		75								6	5	3.5	3.5	3	2.5	3.5	3	2.5	2.5					2.5					
NF100-HEP	100		Selective limit current																										
		30																											
		40								2.5																			
		50								3.5	3	2.5	2.5			2.5													
		60								5	3.5	3	3	2.5		3	2.5	2.5											
		75								6	5	3.5	3.5	3	2.5	3.5	3	2.5	2.5					2.5					
NF160-SP	50		Selective limit current																										
		125																											
		150																											
		160																											
NF160-SP T/A	50		Selective limit current																										
		100 ~ 125																											
		125 ~ 160																											
NF160-HP	100		Selective limit current																										
		125																											
		150																											
		160																											
NF160-HP T/A	100		Selective limit current																										
		100 ~ 125																											
		125 ~ 160																											
NF250-CP	30		Selective limit current																										
		125																											
		150																											
		175																											
		200																											
		225																											
NF250-CP T/A	30		Selective limit current																										
		100 ~ 125																											
		125 ~ 160																											
		150 ~ 200																											
NF250-SP	50		Selective limit current																										
		125																											
		150																											
		175																											
		200																											
		225																											
NF250-SP T/A	50		Selective limit current																										
		100 ~ 125																											
		125 ~ 160																											
		150 ~ 200																											
NF250-HP	100		Selective limit current																										
		125																											
		150																											
		175																											
		200																											
		225																											
NF250-HP T/A	100		Selective limit current																										
		100 ~ 125																											
		125 ~ 160																											
		150 ~ 200																											

Icu: Rated breaking capacity

Main Breaker		Type	NF800-CEP						NF800-SEP						NF1000-SS						NF1250-SS						NF1600-SS					
Branch Breaker		Icu(kA)	50						85						125						125						125					
Type	Icu(kA)	Rated current (A)	400	450	500	600	700	800	400	450	500	600	700	800	500	600	700	800	900	1000	600	700	800	1000	1200	1250	800	1000	1200	1400	1500	1600
NF100-SEP	50		Selective limit current																													
		30	15						18						50						50											
		40																														
		50																														
		60																														
		75																														
NF100-HEP	100		Selective limit current																													
		30	25						35						100						100											
		40																														
		50																														
		60																														
		75																														
NF160-SP	50		Selective limit current																													
		125	10						10						50						50											
		150	5	4	4	3	3	2.5	5	4	4	3	3	2.5							7.5						4.5					
		160	6	5	5	4	3.5	3	6	5	5	4	3.5	3							7.5						4.5					
NF160-SP T/A	50		Selective limit current																													
		100 ~ 125	10						10						50						50											
		125 ~ 160	4	3.5	3	2.5	2.5	4	3.5	3	2.5	2.5																				
NF160-HP	100		Selective limit current																													
		125	10						10						50						50											
		150	5	4	4	3	3	2.5	5	4	4	3	3	2.5							7.5						4.5					
		160	6	5	5	4	3.5	3	6	5	5	4	3.5	3							7.5						4.5					
NF160-HP T/A	100		Selective limit current																													
		100 ~ 125	10						10						50						50											
		125 ~ 160	4	3.5	3	2.5	2.5	4	3.5	3	2.5	2.5																				
NF250-CP	30		Selective limit current																													
		125	7.5						7.5						25						25											
		150	5	4	4	3	3	2.5	5	4	4	3	3	2.5							7.5						4.5					
		175	7	6	5	5	4	3.5	7	6	5	5	4	3.5							7.5						7.5					
		200	8	7	6	5	5	4	8	7	6	5	5	4							7.5						7.5					
		225	8	8	7	6	5	4	8	8	7	6	5	4							7.5	7.5					7.5	7.5				
NF250-CP T/A	30		Selective limit current																													
		100 ~ 125	7.5						7.5						25						25											
		125 ~ 160	4	3.5	3	2.5	2.5	4	3.5	3	2.5	2.5																				
		150 ~ 200	6	5	5	4	3.5	3	6	5	5	4	3.5	3													4.5					
NF250-SP	50		Selective limit current																													
		125	10						10						50						50											
		150	5	4	4	3	3	2.5	5	4	4	3	3	2.5							7.5						4.5					
		175	7	6	5	5	4	3.5	7	6	5	5	4	3.5							7.5						7.5					
		200	8	7	6	5	5	4	8	7	6	5	5	4							7.5						7.5					
		225	8	8	7	6	5	4	8	8	7	6	5	4							7.5	7.5					7.5	7.5				
NF250-SP T/A	50		Selective limit current																													
		100 ~ 125	10						10						50						50											
		125 ~ 160	4	3.5	3	2.5	2.5	4	3.5	3	2.5	2.5																				
		150 ~ 200	6	5	5	4	3.5	3	6	5	5	4	3.5	3													4.5					
NF250-HP	100		Selective limit current																													
		125	10						10						50						50											
		150	5	4	4	3	3	2.5	5	4	4	3	3	2.5							7.5						4.5					
		175	7	6	5	5	4	3.5	7	6	5	5	4	3.5							7.5						7.5					
		200	8	7	6	5	5	4	8	7	6	5	5	4							7.5						7.5					
		225	8	8	7	6	5	4	8	8	7	6	5	4							7.5	7.5					7.5	7.5				
NF250-HP T/A	100		Selective limit current																													
		100 ~ 125	10						10						50						50											
		125 ~ 160	4	3.5	3	2.5	2.5	4	3.5	3	2.5	2.5																				
		150 ~ 200	6	5	5	4	3.5	3	6	5	5	4	3.5	3													4.5					

Icu: Rated breaking capacity

SELECTIVE-INTERRUPTION COMBINATIONS (DISCRIMINATION) 230VAC (Sym. kA)

Main Breaker Branch Breaker		Type	NF100-SEP						NF250-SEP						NF400-SEP						NF630-SEP																											
		Icu(kA)	50						50						85						85																											
Type	Icu(kA)	Rated current (A)	30	40	50	60	75	100	125	150	175	200	225	250	200	225	250	300	350	400	300	350	400	500	600	630																						
NF250-SEP	50		Selective limit current																																													
		125	6.4												10																																	
		150																									7	6	6	5	4	3.5	5	4	3.5	3	2.5											
		175																									8	7	7	6	5	4	6	5	4	3.5	3	2.5										
		200																									10	8	8	6	6	5	6	6	5	4	3	3										
		225																																						10	10	7	6	6	7	6	6	5
250																																						10	8	7	6	8	7	6	5	4	4	
NF250-HEP	100		Selective limit current																																													
		125	6.4												10																																	
		150																								7	6	6	5	4	3.5	5	4	3.5	3	2.5												
		175																								8	7	7	6	5	4	6	5	4	3.5	3	2.5											
		200																								10	8	8	6	6	5	6	6	5	4	3	3											
		225																																					10	10	7	6	6	7	6	6	5	3.5
250																																					10	8	7	6	8	7	6	5	4	4		
NF400-CP	50		Selective limit current																																													
		250																			9.5																											
		300																			10	8	7	6	5	4																						
		350																			10	8	7	6	5	4																						
400																			10	8	6	6																										
NF400-SP	85		Selective limit current																																													
		250																			9.5																											
		300																			10	8	6	6																								
		350																			10	8	7																									
400																			10	10	8																											
NF400-SEP	85		Selective limit current																																													
		200																			9.5																											
		225																			7	6	6	5	3.5	3.5																						
		250																			8	7	6	5	4	4																						
		300																			10	8	7	6	5	4																						
		350																			10	8	7	6	5																							
400																			10	8	6	6																										
NF400-HEP	100		Selective limit current																																													
		200																			9.5																											
		225																			7	6	6	5	3.5	3.5																						
		250																			8	7	6	5	4	4																						
		300																			10	8	7	6	5	4																						
		350																			10	8	7	6	5																							
400																			10	8	6	6																										
NF630-CP	50		Selective limit current																																													
		500																																														
		600																																														
630																																																
NF630-SP	50		Selective limit current																																													
		500																																														
		600																																														
630																																																
NF630-SEP	85		Selective limit current																																													
		300																																														
		350																																														
		400																																														
		500																																														
		600																																														
630																																																
NF630-HEP	100		Selective limit current																																													
		300																																														
		350																																														
		400																																														
		500																																														
		600																																														
630																																																

Icu: Rated breaking capacity

Main Breaker		Type	NF800-CEP						NF800-SEP						NF1000-SS						NF1250-SS						NF1600-SS											
Branch Breaker		Icu(kA)	50						85						125						125						125											
Type	Icu(kA)	Rated current (A)	400	450	500	600	700	800	400	450	500	600	700	800	500	600	700	800	900	1000	600	700	800	1000	1200	1250	800	1000	1200	1400	1500	1600						
NF250-SEP	50		Selective limit current																																			
		125	10						10						50						50																	
		150	3.5	3	3	2.5			3.5	3	3	2.5			10	7.5	7.5	7.5			7.5	7.5	7.5			6	4.5	4.5	4.5									
		175	4	3.5	3.5	3	2.5		4	3.5	3.5	3	2.5		10	7.5	7.5	7.5			7.5	7.5	7.5			6	4.5	4.5	4.5									
		200	5	4	4	3	3	2.5	5	4	4	3	3	2.5	10	7.5	7.5	7.5			7.5	7.5	7.5			6	4.5	4.5	4.5									
		225	6	5	5	3.5	3	3	6	5	5	3.5	3	3	10	7.5	7.5	7.5			7.5	7.5	7.5			6	4.5	4.5	4.5									
250	6	6	5	4	3.5	3	6	6	5	4	3.5	3	10	7.5	7.5	7.5			7.5	7.5	7.5			6	4.5	4.5	4.5											
250	7	6	6	5	4	3.5	7	6	6	5	4	3.5	10	7.5	7.5	7.5			7.5	7.5	7.5			6	4.5	4.5	4.5											
NF250-HEP	100		Selective limit current																																			
		125	10						10						50						50																	
		150	3.5	3	3	2.5			3.5	3	3	2.5			10	7.5	7.5	7.5			7.5	7.5	7.5			6	4.5	4.5	4.5									
		175	4	3.5	3.5	3	2.5		4	3.5	3.5	3	2.5		10	7.5	7.5	7.5			7.5	7.5	7.5			6	4.5	4.5	4.5									
		200	5	4	4	3	3	2.5	5	4	4	3	3	2.5	10	7.5	7.5	7.5			7.5	7.5	7.5			6	4.5	4.5	4.5									
		225	6	5	5	3.5	3	3	6	5	5	3.5	3	3	10	7.5	7.5	7.5			7.5	7.5	7.5			6	4.5	4.5	4.5									
250	6	6	5	4	3.5	3	6	6	5	4	3.5	3	10	7.5	7.5	7.5			7.5	7.5	7.5			6	4.5	4.5	4.5											
250	7	6	6	5	4	3.5	7	6	6	5	4	3.5	10	7.5	7.5	7.5			7.5	7.5	7.5			6	4.5	4.5	4.5											
NF400-CP	50		Selective limit current																																			
		250	10						10						20						20																	
		300	7	6	5	5	4	3.5	7	6	6	5	4	3.5													4.5	4.5										
		350	8	7	7	5	5	4	8	7	7	5	5	4													4.5	4.5										
400	10	8	8	6	6	5	10	8	8	6	6	5													6	4.5	4.5	4.5										
400		10	10	7	6	6		10	10	7	6	6						7.5						7.5						6	4.5	4.5	4.5	4.5				
NF400-SP	85		Selective limit current																																			
		250	10						10						20						20																	
		300	10	8	7	6	5	5	10	8	7	6	5	5						7.5	7.5	7.5						7.5						6	6	4.5	4.5	4.5
		350		10	10	7	6	6		10	10	7	6	6						7.5	7.5	7.5						7.5						6	6	4.5	4.5	4.5
400			10	10	7	7			10	10	7	7						7.5	7.5						7.5						6	6	6	6	6			
400				10	8	7				10	8	7						7.5						7.5						6	6	6	6	6				
NF400-SEP	85		Selective limit current																																			
		200	10						10						20						20																	
		225	6	5	5	3.5	3	3	6	5	5	3.5	3	3						10	10						10	7.5	7.5						6	6	6	6
		250	6	6	5	4	3.5	3	6	6	5	4	3.5	3						10	10						10	7.5	7.5						6	6	6	6
		300	7	6	6	5	4	3.5	7	6	6	5	4	3.5						10	10						10	7.5	7.5						6	6	6	6
		350	8	7	7	5	5	4	8	7	7	5	5	4						10	10						10	7.5	7.5						6	6	6	6
400	10	8	7	6	5	5	10	8	7	6	5	5						10	10						10	7.5	7.5						6	6	6	6		
400		10	8	7	6	5		10	8	7	6	5						10	10						10	7.5	7.5						6	6	6	6		
NF630-CP	50		Selective limit current																																			
		500	9.6						9.6												20																	
		600				10	8	7				10	8	7																					6	4.5	4.5	
630					10	8					10	8																				6	6	6				
NF630-SP	50		Selective limit current																																			
		500	9.6						9.6												20																	
		600					10						10																						6			
630																																						
NF630-SEP	85		Selective limit current																																			
		300	9.6						9.6						20																							
		350	8	7	7	5	5	4	8	7	7	5	5	4																						10		
		400	10	8	7	6	5	5	10	8	7	6	5	5																						10		
		500		10	8	7	6	6		10	8	7	6	6																						10		
		600				10	8	7				10	8	7																						10		
630					10	8					10	8																						10				
NF630-HEP	100		Selective limit current																																			
		300	9.6						9.6						20																							
		350	8	7	7	5	5	4	8	7	7	5	5	4																					10			
		400	10	8	7	6	5	5	10	8	7	6	5	5																						10		
		500		10	8	7	6	6		10	8	7	6	6																						10		
		600				10	8	7				10	8	7																						10		
630					10	8					10	8																						10				

Icu: Rated breaking capacity

SELECTIVE-INTERRUPTION COMBINATIONS (DISCRIMINATION) 440VAC (Sym. kA)

Main Breaker Branch Breaker		Type	Icu(kA)	Rated current (A)	NF100-SEP						NF250-SEP						NF400-SEP						NF630-SEP									
					30						50						50						50									
Type	Icu(kA)				30	40	50	60	75	100	125	150	175	200	225	250	200	225	250	300	350	400	300	350	400	500	600	630				
NF30-SP	5		Selective limit current																													
		3	0.8						1.6						3.5						2.5						2.5					
		5																														
		10	4	3	2.5																											
		15	6	5	3.5	3	2.5																									
		20	8	6	5	4	3	2.5																								
NF50-CP	5		Selective limit current																													
		10	0.8						1.6						3.5						2.5						2.5					
		15																														
		20	8	6	5	4	3	2.5																								
		30				10	7	6	5	3.5	3	2.5																				
		40				10			8	6	5	4	3	3	2.5				2.5													
NF50-HP	10		Selective limit current																													
		10	0.8						1.6						3.5						7.5						10					
		15																														
		20	8	6	5	4	3	2.5																								
		30				10	7	6	5	3.5	3	2.5																				
		40				10			8	6	5	4	3	3	2.5				2.5													
NF60-CP	5		Selective limit current																													
		60	1.6						3.5						2.5						2.5						2.5					
NF60-HP	10		Selective limit current																													
		60	1.6						3.5						7.5						10						2.5					
NF100-CP	10		Selective limit current																													
		50							3.5						5						10											
		60							8	7	6	5	5	4	5	5	4	3.5	3	2.5	2.5	2.5										
		75							10		8	7	6	5	4	3.5	3	3	2.5	2.5	2.5	2.5	2.5									
NF100-SP	30		Selective limit current																													
		15							3.5						5						10											
		20							2.5	3	2.5	2.5																				
		30							5	4	3.5	3	2.5	2.5	3	2.5	2.5															
		40							6	5	5	4	3.5	3	4	3.5	3	2.5	2.5													
		50							8	7	6	5	5	4	5	5	4	3.5	3	2.5	2.5	2.5	2.5									
		60							10	8	7	6	5	5	6	5	5	4	3.5	3	3	2.5	2.5									
NF100-SP T/A	30		Selective limit current																													
		15 ~ 20							3.5						5						10											
		20 ~ 25							2.5	3	2.5	2.5																				
		25 ~ 40							4	3.5	3	2.5	2.5																			
		40 ~ 63							6	5	5	4	3.5	3	4	3.5	3	2.5	2.5													
		63 ~ 80							10	8	7	6	6	5	6	6	5	4	3.5	3	3.5	3	2.5	2.5								
NF100-HP	50		Selective limit current																													
		15							3.5						7.5						18											
		20							2.5	3	2.5	2.5																				
		30							5	4	3.5	3	2.5	2.5	3	3.5	2.5															
		40							6	5	5	4	3.5	3	4	3.5	3	2.5	2.5													
		50							8	7	6	5	5	4	5	5	4	3.5	3	2.5	2.5	2.5	2.5									
		60							10	8	7	6	5	5	6	5	5	4	3.5	3	3	2.5	2.5									
NF100-HP T/A	50		Selective limit current																													
		15 ~ 20							3.5						7.5						18											
		20 ~ 25							2.5	3	2.5	2.5																				
		25 ~ 40							4	3.5	3	2.5	2.5																			
		40 ~ 63							6	5	5	4	3.5	3	4	3.5	3	2.5	2.5													
		63 ~ 80							10	8	7	6	6	5	6	6	5	4	3.5	3	3.5	3	2.5	2.5								

Icu: Rated breaking capacity

Main Breaker		Type	NF800-CEP						NF800-SEP						NF1000-SS						NF1250-SS						NF1600-SS					
Branch Breaker		Icu(kA)	36						42						85						85						85					
Type	Icu(kA)	Rated current (A)	400	450	500	600	700	800	400	450	500	600	700	800	500	600	700	800	900	1000	600	700	800	1000	1200	1250	800	1000	1200	1400	1500	1600
NF30-SP	5		Selective limit current																													
		3	2.5						2.5						5						5						5					
		5																														
		10																														
		15																														
		20																														
NF50-CP	5		Selective limit current																													
		10	2.5						2.5						5						5						5					
		15																														
		20																														
		30																														
		40																														
NF50-HP	10		Selective limit current																													
		10	10						10						10						10						10					
		15																														
		20																														
		30																														
		40																														
NF60-CP	5		Selective limit current																													
		60	2.5						2.5						5						5						5					
NF60-HP	10		Selective limit current																													
		60	10						10						10						10						10					
NF100-CP	10		Selective limit current																													
		50	10						10						10						10						10					
		60																														
		75	3	2.5	2.5				3	2.5	2.5																					
NF100-SP	30		Selective limit current																													
		15	10						10						22						22						22					
		20																														
		30																														
		40																														
		50																														
NF100-SP T/A	30		Selective limit current																													
		15 ~ 20	10						10						22						22						22					
		20 ~ 25																														
		25 ~ 40																														
		40 ~ 63																														
		63 ~ 80	2.5	2.5					2.5	2.5																						
NF100-HP	50		Selective limit current																													
		15	18						18						50						50						50					
		20																														
		30																														
		40																														
		50																														
NF100-HP T/A	50		Selective limit current																													
		15 ~ 20	18						18						50						50						50					
		20 ~ 25																														
		25 ~ 40																														
		40 ~ 63																														
		63 ~ 80	2.5	2.5					2.5	2.5																						

Icu: Rated breaking capacity

SELECTIVE-INTERRUPTION COMBINATIONS (DISCRIMINATION) 440VAC (Sym. kA)

Main Breaker Branch Breaker		Type	Icu(kA)	Rated current (A)	NF100-SEP						NF250-SEP						NF400-SEP						NF630-SEP							
					30						50						50						50							
Type	Icu(kA)				30	40	50	60	75	100	125	150	175	200	225	250	200	225	250	300	350	400	300	350	400	500	600	630		
NF100-SEP	25		Selective limit current																											
		30							3.5						5						10									
		40						2.5										2.5												
		50						3.5	3	2.5	2.5							3	2.5	2.5										
		60						6	5	3.5	3.5	3	2.5					3.5	3	2.5	2.5				2.5					
		75						7	6	5	4	3.5	3.5	4	4	3.5	3	2.5	4	4	3.5	3	2.5	3	2.5					
100						10	8	6	6	5	5	6	5	5	3.5	3	3	3.5	3	3	2.5	3.5	3	3	2.5					
NF100-HEP	50		Selective limit current																											
		30							3.5						7.5						18									
		40						2.5										2.5												
		50						3.5	3	2.5	2.5							3	2.5	2.5										
		60						6	5	3.5	3.5	3	2.5					3.5	3	2.5	2.5				2.5					
		75						7	6	5	4	3.5	3.5	4	4	3.5	3	2.5	4	4	3.5	3	2.5	3	2.5					
100						10	8	6	6	5	5	6	5	5	3.5	3	3	3.5	3	3	2.5	3.5	3	3	2.5					
NF160-SP	25		Selective limit current																											
		125							3.5												10									
		150											10	10	8										6	6	5	4	3	3
		160																							8	7	6	5	4	3.5
NF160-SP T/A	25		Selective limit current																											
		100 ~ 125							3.5												10									
		125 ~ 160											10	10	8	7									5	5	4	3	2.5	2.5
NF160-HP	50		Selective limit current																											
		125							3.5												10									
		150											10	10	8										6	6	5	4	3	3
		160																							8	7	6	5	4	3.5
NF160-HP T/A	50		Selective limit current																											
		100 ~ 125							3.5												10									
		125 ~ 160											10	10	8	7									5	5	4	3	2.5	2.5
NF250-CP	15		Selective limit current																											
		125																			7.5									
		150																							6	6	5	4	3	3
		175																							8	7	6	5	4	3.5
		200																							10	8	7	5	5	4
		225																							10	10	8	6	5	5
250																							10	8	7	6	6	6		
NF250-CP T/A	15		Selective limit current																											
		100 ~ 125																			7.5									
		125 ~ 160																			10									
		150 ~ 200																							5	5	4	3	2.5	2.5
200 ~ 250																							5	5	4	3	2.5	2.5		
NF250-SP	25		Selective limit current																											
		125																			10									
		150																							6	6	5	4	3	3
		175																							8	7	6	5	4	3.5
		200																							10	8	7	5	5	4
		225																							10	10	8	6	5	5
250																							10	8	7	6	6	6		
NF250-SP T/A	25		Selective limit current																											
		100 ~ 125																			10									
		125 ~ 160																			10									
		150 ~ 200																							5	5	4	3	2.5	2.5
200 ~ 250																							5	5	4	3	2.5	2.5		
NF250-HP	50		Selective limit current																											
		125																			10									
		150																							6	6	5	4	3	3
		175																							8	7	6	5	4	3.5
		200																							10	8	7	5	5	4
		225																							10	10	8	6	5	5
250																							10	8	7	6	6	6		
NF250-HP T/A	50		Selective limit current																											
		100 ~ 125																			10									
		125 ~ 160																			10									
		150 ~ 200																							5	5	4	3	2.5	2.5
200 ~ 250																							5	5	4	3	2.5	2.5		

Icu: Rated breaking capacity

SELECTIVE-INTERRUPTION COMBINATIONS (DISCRIMINATION) 440VAC (Sym. kA)

Main Breaker Branch Breaker		Type	NF100-SEP						NF250-SEP						NF400-SEP						NF630-SEP					
		Icu(kA)	50						50						85						85					
Type	Icu(kA)	Rated current (A)	30	40	50	60	75	100	125	150	175	200	225	250	200	225	250	300	350	400	300	350	400	500	600	630
NF250-SEP	25		Selective limit current																							
		125																			10					
		150																			5	4	3.5	3	2.5	2.5
		175																			6	5	4	3.5	3	2.5
		200																			6	6	5	4	3	3
		225																			7	6	6	5	3.5	3.5
		250																			8	7	6	5	4	4
																					10	8	7	6	5	5
NF250-HEP	50		Selective limit current																							
		125																			10					
		150																			5	4	3.5	3	2.5	2.5
		175																			6	5	4	3.5	3	2.5
		200																			6	6	5	4	3	3
		225																			7	6	6	5	3.5	3.5
		250																			8	7	6	5	4	4
																					10	8	7	6	5	5
NF400-CP	25		Selective limit current																							
		250																			9.5					
		300																			10	8	7	6	5	5
		350																				10	8	7	6	5
		400																					10	8	6	6
																								10	7	7
NF400-SP	42		Selective limit current																							
		250																			9.5					
		300																				10	8	6	6	
		350																					10	8	7	
		400																						10	10	8
																								10	10	
NF400-SEP	42		Selective limit current																							
		200																			9.5					
		225																			7	6	6	5	3.5	3.5
		250																			8	7	6	5	4	4
		300																			10	8	7	6	5	5
		350																				10	8	7	6	5
		400																					10	8	6	6
																								10	7	7
NF400-HEP	65		Selective limit current																							
		200																			9.5					
		225																			7	6	6	5	3.5	3.5
		250																			8	7	6	5	4	4
		300																			10	8	7	6	5	5
		350																				10	8	7	6	5
		400																					10	8	6	6
																								10	7	7
NF630-CP	36		Selective limit current																							
		500																								
		600																								
		630																								
NF630-SP	42		Selective limit current																							
		500																								
		600																								
		630																								
NF630-SEP	42		Selective limit current																							
		300																								
		350																								
		400																								
		500																								
		600																								
		630																								
NF630-HEP	65		Selective limit current																							
		300																								
		350																								
		400																								
		500																								
		600																								
		630																								

Icu: Rated breaking capacity

Main Breaker		Type	AE2000-SS						AE2500-SS						AE3200-SS						AE4000-SSC													
Branch Breaker		Ics(kA)	85						85						85						85													
Type	Icu(kA)	Rated current (A)	1000	1200	1400	1600	1800	2000	1250	1500	1750	2000	2250	2500	1600	1920	2240	2560	2880	3200	3200	3600	4000											
NF100-CP	25		Selective limit current																															
		60	In=1000 ... 25						1600 ... 25						2000 ... 25						2500 ... 25						3200 ... 25				4000 ... 25			
		75																																
		100																																
NF100-SP	50		Selective limit current																															
		60	In=1000 ... 45(50)						1600 ... 50						2000 ... 50						2500 ... 50						3200 ... 50				4000 ... 50			
		75																																
		100																																
NF100-SP T/A	50		Selective limit current																															
		63 ~ 80	In=1000 ... 45(50)						1600 ... 50						2000 ... 50						2500 ... 50						3200 ... 50				4000 ... 50			
		80 ~ 100																																
NF100-HP	100		Selective limit current																															
		60	In=1000 ... 85						1600 ... 85						2000 ... 85						2500 ... 85						3200 ... 85				4000 ... 85			
		75																																
		100																																
NF100-HP T/A	100		Selective limit current																															
		63 ~ 80	In=1000 ... 85						1600 ... 85						2000 ... 85						2500 ... 85						3200 ... 85				4000 ... 85			
		80 ~ 100																																
NF100-SEP	50		Selective limit current																															
		60	In=1000 ... 45(50)						1600 ... 50						2000 ... 50						2500 ... 50						3200 ... 50				4000 ... 50			
		75																																
		100																																
NF100-HEP	100		Selective limit current																															
		60	In=1000 ... 85						1600 ... 85						2000 ... 85						2500 ... 85						3200 ... 85				4000 ... 85			
		75																																
		100																																
NF160-SP	50		Selective limit current																															
		125	3																															
		150	3	3										3																				
		160	3	3	3									3																				
NF160-SP T/A	50		Selective limit current																															
		100 ~ 125	In=1000 ... 24(50)						1600 ... 42(50)						2000 ... 50						2500 ... 50						3200 ... 50				4000 ... 50			
		125 ~ 160																																
NF160-HP	100		Selective limit current																															
		125	3																															
		150	3	3										3																				
		160	3	3	3									3																				
NF160-HP T/A	100		Selective limit current																															
		100 ~ 125	In=1000 ... 25(65)						1600 ... 85						2000 ... 85						2500 ... 85						3200 ... 85				4000 ... 85			
		125 ~ 160																																
NF250-CP	30		Selective limit current																															
		125	3																															
		150	3	3										3																				
		175	4	3	3									3	3																			
		200	4	3	3	3								3	3	3						3												
		225	4	4	3	3	3							4	3	3						3	3											
250	4	3	3									3	3																					
NF250-CP T/A	30		Selective limit current																															
		100 ~ 125	In=1000 ... 30						1600 ... 30						2000 ... 30						2500 ... 30						3200 ... 30				4000 ... 30			
		125 ~ 160																																
		150 ~ 200	3	3										3																				
		200 ~ 250	4	3	3									3	3																			

Icu: Rated breaking capacity

SELECTIVE-INTERRUPTION COMBINATIONS (DISCRIMINATION) 230VAC (Sym. kA)

Main Breaker Branch Breaker		Type	AE630-SS						AE1000-SS						AE1250-SS						AE1600-SS																	
		Ics(kA)	65						65						65						65																	
Type	Icu(kA)	Rated current (A)	315	378	441	504	567	630	500	600	700	800	900	1000	625	750	875	1000	1125	1250	800	960	1120	1280	1440	1600												
NF250-SP	50		Selective limit current																																			
			In=500 7.5(50)						630 15(50)						800 19(50)						1000 24(50)						1250 30(50)						1600 42(50)					
		125	8	6	6	6	4	4	6	4	4	3	3	3	4	3	3	3			3	3																
		150	10	8	6	6	6	6	6	6	4	4	3	3	6	4	4	3	3	3	3	3	4	3	3	3												
		175		10	8	8	6	6	8	6	6	4	4	4	6	6	4	4	3	3	4	4	3	3														
		200			8	8	8	6	8	6	6	6	4	4	6	6	6	4	4	3	3	4	4	3	3	3												
225			10	8	8	8	8	8	6	6	6	4	8	6	6	4	4	4	6	6	4	4	3	3														
250			10	8	8	6	6	8	6	6	4	4	6	6	4	4	3	3	4	4	3	3																
NF250-SP	50		Selective limit current																																			
			In=500 7.5(50)						630 15(50)						800 19(50)						1000 24(50)						1250 30(50)						1600 42(50)					
		100 ~ 125	6	6	6	4	4	3	4	3	3	3			3	3	3					3																
		125 ~ 160	6	6	6	4	4	3	4	3	3	3			3	3	3					3																
		150 ~ 200	10	8	8	6	6	6	6	6	4	4	3	3	6	4	4	3	3	3	3	3	4	3	3	3												
NF250-HP	100		Selective limit current																																			
			In=500 7.5(65)						630 9.4(65)						800 12(65)						1000 25(65)						1250 40(65)						1600 65					
		125	8	6	6	6	4	4	6	4	4	3	3	3	4	3	3	3			3	3																
		150	10	8	6	6	6	6	6	6	4	4	3	3	6	4	4	3	3	3	3	4	3	3	3													
		175		10	8	8	6	6	8	6	6	4	4	4	6	6	4	4	3	3	4	4	3	3														
		200			8	8	8	6	8	6	6	6	4	4	6	6	6	4	4	3	3	6	4	4	3	3												
225			10	8	8	8	8	8	6	6	6	4	8	6	6	4	4	4	6	6	4	4	3	3														
250			10	8	8	6	6	8	6	6	4	4	6	6	4	4	3	3	4	4	3	3																
NF250-HP	100		Selective limit current																																			
			In=500 7.5(65)						630 9.4(65)						800 12(65)						1000 25(65)						1250 40(65)						1600 65					
		100 ~ 125	6	6	6	4	4	3	4	3	3	3			3	3	3					3																
		125 ~ 160	6	6	6	4	4	3	4	3	3	3			3	3	3					3																
		150 ~ 200	10	8	8	6	6	6	6	6	4	4	3	3	6	4	4	3	3	3	3	4	3	3	3													
NF250-SEP	50		Selective limit current																																			
			In=500 7.5(50)						630 15(50)						800 19(50)						1000 24(50)						1250 30(50)						1600 42(50)					
		125	6	6	4	4	3	3	4	3	3				3	3																						
		150	6	6	6	4	4	3	4	4	3	3	3		3	3	3					3																
		175	8	6	6	6	4	4	6	4	4	3	3	3	4	3	3	3				3	3															
		200	8	8	6	6	6	4	6	6	4	4	3	3	4	4	3	3	3			4	4	3	3													
225	10	8	8	6	6	6	6	6	4	4	4	3	6	4	4	3	3	3	3	4	3	3	3															
250	10	10	8	8	6	6	8	6	6	4	4	4	6	6	4	4	3	3	4	4	3	3	3															
NF400-CP	50		Selective limit current																																			
			In=500 -						630 9.4(50)						800 12(50)						1000 15(50)						1250 20(50)						1600 30(50)					
		250					6	6		6	6	4	4	4	6	6	4	4	3	3	4	4	3	3	3													
		300									6	6	6	6		6	6	4	4	4	6	4	4	3	3													
		350									6	6	6	6		6	6	4	4	4	6	6	4	4	4	3												
NF400-SP	85		Selective limit current																																			
			In=500 -						630 9.4(65)						800 12(65)						1000 15(65)						1250 20(65)						1600 30(65)					
		250					8	8		8	8	8	6	6	8	6	6	6	4	4	8	6	4	4	3	3												
		300									8	8	6	6		8	8	6	6	6	8	6	6	6	4	4												
		350									8	8	8			8	8	6	6	8	6	6	8	6	6	6	4											
400									8					8	8	6	6	8	6	6	8	6	6	6	4													
NF400-SEP	85		Selective limit current																																			
			In=500 -						630 9.4(65)						800 12(65)						1000 15(65)						1250 20(65)						1600 30(65)					
		200					6	4		6	4	4	3	3	4	4	3	3	3			4	3	3														
		225					6	6		6	4	4	4	3	6	4	4	3	3	3	3	4	3	3	3													
		250					6	6		6	6	4	4	4	6	6	4	4	3	3	4	4	3	3	3													
		300					8	6		8	6	6	6	4	6	6	6	4	4	3	6	4	4	3	3	3												
350					8	8		8	8	6	6	6	8	6	6	6	4	4	6	6	4	4	3	3														
400					10	8		10	8	8	6	6	8	8	6	6	6	4	4	8	6	6	4	4	4													
NF400-HEP	100		Selective limit current																																			
			In=500 -						630 9.4(65)						800 12(65)						1000 15(65)						1250 20(65)						1600 30(65)					
		200					6	4		6	4	4	3	3	4	4	3	3	3			4	3	3														
		225					6	6		6	4	4	4	3	6	4	4	3	3	3	4	3	3	3														
		250					6	6		6	6	4	4	4	6	6	4	4	3	3	4	4	3	3	3													
		300					8	6		8	6	6	6	4	6	6	4	4	3	3	6	4	4	3	3	3												
350					8	8		8	8	6	6	6	8	6	6	6	4	4	6	6	4	4	3	3														
400					10	8		10	8	8	6	6	8	8	6	6	6	4	4	8	6	6	4	4	4													

Icu: Rated breaking capacity

Main Breaker		Type	AE2000-SS						AE2500-SS					AE3200-SS					AE4000-SSC												
Branch Breaker		Ics(kA)	85						85					85					85												
Type	Icu(kA)	Rated current (A)	1000	1200	1400	1600	1800	2000	1250	1500	1750	2000	2250	2500	1600	1920	2240	2560	2880	3200	3200	3600	4000								
NF250-SP	50		Selective limit current																												
			In=1000 ... 24(50)						1600 ... 42(50)					2000 ... 50					2500 ... 50					3200 ... 50				4000 ... 50			
		125	3						3																						
		150	3	3					3																						
		175	4	3	3				3	3																					
		200	4	3	3	3			3	3	3					3															
NF250-SP T/A	50		Selective limit current																												
		100 ~ 125																													
		125 ~ 160																													
		150 ~ 200	3	3					3																						
NF250-HP	100		Selective limit current																												
			In=1000 ... 25(65)						1600 ... 85					2000 ... 85					2500 ... 85					3200 ... 85				4000 ... 85			
		125	3						3																						
		150	3	3					3																						
		175	4	3	3				3	3																					
		200	4	3	3	3			3	3	3					3															
NF250-HP T/A	100		Selective limit current																												
		100 ~ 125																													
		125 ~ 160																													
		150 ~ 200	3	3					3																						
NF250-SEP	50		Selective limit current																												
			In=1000 ... 24(50)						1600 ... 42(50)					2000 ... 50					2500 ... 50					3200 ... 50				4000 ... 50			
		125																													
		150																													
		175	3																												
		200	3	3					3	3																					
NF250-HEP	100		Selective limit current																												
			In=1000 ... 25(65)						1600 ... 85					2000 ... 85					2500 ... 85					3200 ... 85				4000 ... 85			
		125																													
		150																													
		175	3																												
		200	3	3					3																						
NF400-CP	50		Selective limit current																												
			In=1000 ... 15(50)						1600 ... 30(50)					2000 ... 48(50)					2500 ... 50					3200 ... 50				4000 ... 50			
		250	4	3	3				3	3																					
		300	4	4	3	3	3		4	3	3					3															
		350	6	4	4	3	3	3	4	3	3	3				3	3														
NF400-SP	85		Selective limit current																												
			In=1000 ... 15(65)						1600 ... 30(65)					2000 ... 48(65)					2500 ... 70					3200 ... 85				4000 ... 85			
		250	6	4	4	3	3	3	4	3	3	3				3															
		300	6	6	4	4	3	3	6	4	4	3	3	3	4	3	3														
		350	8	6	6	4	4	4	6	4	4	3	3		4	4	3	3			3	3									
NF400-SEP	85		Selective limit current																												
			In=1000 ... 15(65)						1600 ... 30(65)					2000 ... 48(65)					2500 ... 70					3200 ... 85				4000 ... 85			
		200	3	3					3																						
		225	3	3					3																						
		250	4	3	3				3	3																					
		300	4	4	3	3	3		3	3	3					3															
NF400-HEP	100		Selective limit current																												
			In=1000 ... 15(65)						1600 ... 30(65)					2000 ... 48(65)					2500 ... 70					3200 ... 85				4000 ... 85			
		200	3	3					3																						
		225	3	3					3																						
		250	4	3	3				3	3																					
		300	4	4	3	3	3		3	3	3					3															

Icu: Rated breaking capacity

SELECTIVE-INTERRUPTION COMBINATIONS (DISCRIMINATION) 230VAC (Sym. kA)

Main Breaker Branch Breaker		Type	AE630-SS					AE1000-SS					AE1250-SS					AE1600-SS															
		Ics(kA)	65					65					65					65															
Type	Icu(kA)	Rated current (A)	315	378	441	504	567	630	500	600	700	800	900	1000	625	750	875	1000	1125	1250	800	960	1120	1280	1440	1600							
NF630-CP	50		Selective limit current																														
		500	In=500 ----					630 ----					800 ----					1000 ----					1250 ---- 18.7(50)					1600 ---- 24(50)					
		600																					6	6				6	6	6	4		
		630																															
NF630-SP	50		Selective limit current																														
		500	In=500 ----					630 ----					800 ----					1000 ----					1250 ---- 18.7(50)					1600 ---- 24(50)					
		600																					8	8				10	8	8	6		
		630																															
NF630-SEP	85		Selective limit current																														
		300	In=500 ----					630 ---- 9.4(65)					800 ---- 12(65)					1000 ---- 15(65)					1250 ---- 18.7(65)					1600 ---- 24(65)					
		350			8	8	6		8	6	6	6	4	6	6	6	4	4	4	6	6	6	4	4	4	6	6	4	4	4	4		
		400				8	8		8	8	6	6	6	8	6	6	6	4	4	8	6	6	6	4	4	8	6	6	4	4	4		
		500									10	10	8				8	8	6	6	10	10	6	6	6	6	10	6	6	6	4		
		600										10	8						8	8	6	6	10	8	6	6	6	10	8	6	6	6	
630											8						8	8	8			8	6	6	6	8	6	6	6	6			
NF630-HEP	100		Selective limit current																														
		300	In=500 ----					630 ---- 9.4(65)					800 ---- 12(65)					1000 ---- 15(65)					1250 ---- 18.7(65)					1600 ---- 24(65)					
		350			8	8	6		8	6	6	6	4	6	6	6	4	4	4	6	6	6	4	4	4	6	6	4	4	4	4		
		400				8	8		8	8	6	6	6	8	6	6	6	4	4	8	6	6	6	4	4	8	6	6	4	4	4		
		500									10	10	8				8	8	6	6	10	10	6	6	6	6	10	6	6	6	4		
		600										10	8						8	8	6	10	8	6	6	6	10	8	6	6	6		
630											8						8	8	8			8	6	6	6	8	6	6	6	6			
NF800-CEP	50		Selective limit current																														
		400	In=500 ----					630 ----					800 ---- 12(50)					1000 ---- 15(50)					1250 ---- 18.7(50)					1600 ---- 24(50)					
		450									8	8	6	6	6	6	6	6	4	4	8	6	6	6	4	4	8	6	6	4	4	4	
		500									8	8	6				8	8	6	6	8	8	6	6	6	6	8	8	6	6	4		
		600											8						8	8	6			8	8	6	6			8	8	6	6
		700																	8	8									8	8	6	6	
800																	8	8	8									8	8	8			
NF800-SEP	85		Selective limit current																														
		400	In=500 ----					630 ----					800 ---- 12(65)					1000 ---- 15(65)					1250 ---- 18.7(65)					1600 ---- 24(65)					
		450									8	8	6	6	6	6	6	6	4	4	8	6	6	6	4	4	8	6	6	4	4	4	
		500									8	8	8				8	8	6	6	8	8	6	6	6	6	8	8	6	6	6	4	
		600											8						8	8	6			8	8	6	6			8	8	6	6
		700																	8	8									8	8	6	6	
800																	8	8	8									8	8	8			
NF800-HEP	100		Selective limit current																														
		400	In=500 ----					630 ----					800 ---- 12(65)					1000 ---- 15(65)					1250 ---- 18.7(65)					1600 ---- 24(65)					
		450									8	8	6	6	6	6	6	6	4	4	8	6	6	6	4	4	8	6	6	4	4	4	
		500									8	8	8				8	8	6	6	8	8	6	6	6	6	8	8	6	6	6	4	
		600											8						8	8	6			8	8	6	6			8	8	6	6
		700																	8	8									8	8	6	6	
800																	8	8	8									8	8	8			

Icu: Rated breaking capacity

Main Breaker		Type	AE2000-SS						AE2500-SS						AE3200-SS						AE4000-SSC								
Branch Breaker		Ics(kA)	85						85						85						85								
Type	Icu(kA)	Rated current (A)	1000	1200	1400	1600	1800	2000	1250	1500	1750	2000	2250	2500	1600	1920	2240	2560	2880	3200	3200	3600	4000						
NF630-CP	50		Selective limit current																										
		500	In=1000 ... -						1600 ... 24(50)						2000 ... 30(50)						2500 ... 40(50)			3200 ... 50			4000 ... 50		
		600		6	6	4	4	4	6	6	6	4	4	4	4	4	4	4	4	4	4								
		630			6	6	6	6		6	6	6	4	4	4	6	4	4	4	4	4	4	4	4					
NF630-SP	50		Selective limit current																										
		500	In=1000 ... -						1600 ... 24(50)						2000 ... 30(50)						2500 ... 40(50)			3200 ... 50			4000 ... 50		
		600		8	8	6	6	6	8	6	6	6	4	4	6	6	4	4	4	4	4								
		630			10	8	8	6		8	8	6	6	6	8	6	6	6	4	4	4	4	4	4					
NF630-SEP	85		Selective limit current																										
		300	In=1000 ... 15(65)						1600 ... 24(65)						2000 ... 30(65)						2500 ... 40(65)			3200 ... 60(65)			4000 ... 85		
		350	4	4	4	4	4	4	4	4	4	4				4													
		400	6	4	4	4	4	4	4	4	4	4	4			4	4												
		500	8	6	6	4	4	4	6	6	4	4	4	4	4	4	4	4	4	4									
		600	8	8	6	6	6	4	6	6	6	4	4	4	6	4	4	4	4	4	4	4	4	4					
NF630-HEP	100		Selective limit current																										
		300	In=1000 ... 15(65)						1600 ... 24(65)						2000 ... 30(65)						2500 ... 40(65)			3200 ... 60(65)			4000 ... 85		
		350	4	4	4	4	4	4	4	4	4	4				4													
		400	6	4	4	4	4	4	4	4	4	4	4			4	4												
		500	8	6	6	4	4	4	6	6	4	4	4	4	4	4	4	4	4	4	4								
		600	8	8	6	6	6	4	6	6	6	4	4	4	6	4	4	4	4	4	4	4	4	4					
NF800-CEP	50		Selective limit current																										
		400	In=1000 ... 15(50)						1600 ... 24(50)						2000 ... 30(50)						2500 ... 40(50)			3200 ... 50			4000 ... 50		
		450	6	6	4	4	4	4	4	4	4	4	4	4		4	4	4											
		500	8	6	6	4	4	4	6	6	4	4	4	4	4	4	4	4	4	4	4								
		600	8	8	6	6	6	4	6	6	6	4	4	4	6	4	4	4	4	4	4	4	4	4					
		700		8	8	6	6	6	8	6	6	6	4	4	6	6	4	4	4	4	4	4	4	4					
NF800-SEP	85		Selective limit current																										
		400	In=1000 ... 15(65)						1600 ... 24(65)						2000 ... 30(65)						2500 ... 40(65)			3200 ... 60(65)			4000 ... 85		
		450	6	6	4	4	4	4	4	4	4	4	4	4		4	4	4											
		500	8	6	6	4	4	4	6	6	4	4	4	4	4	4	4	4	4	4	4								
		600	8	8	6	6	6	4	6	6	6	4	4	4	6	4	4	4	4	4	4	4	4	4					
		700		8	8	6	6	6	8	6	6	6	4	4	6	6	4	4	4	4	4	4	4	4					
NF800-HEP	100		Selective limit current																										
		400	In=1000 ... 15(65)						1600 ... 24(65)						2000 ... 30(65)						2500 ... 40(65)			3200 ... 60(65)			4000 ... 85		
		450	6	6	4	4	4	4	4	4	4	4	4	4		4	4	4											
		500	8	6	6	4	4	4	6	6	4	4	4	4	4	4	4	4	4	4	4								
		600	8	8	6	6	6	4	6	6	6	4	4	4	6	4	4	4	4	4	4	4	4	4					
		700		8	8	6	6	6	8	6	6	6	4	4	6	6	4	4	4	4	4	4	4	4					
800		8	8	6	6	8	8	6	6	6	4	8	6	6	4	4	4	4	4	4	4	4							

Icu: Rated breaking capacity

SELECTIVE-INTERRUPTION COMBINATIONS (DISCRIMINATION) 440VAC (Sym. kA)

Main Breaker Branch Breaker		Type	AE630-SS						AE1000-SS						AE1250-SS						AE1600-SS																	
		Ics(kA)	65						65						65						65																	
Type	Icu(kA)	Rated current (A)	315	378	441	504	567	630	500	600	700	800	900	1000	625	750	875	1000	1125	1250	800	960	1120	1280	1440	1600												
NF100-CP	10		Selective limit current																																			
		60	In=500 ... 7.5(10)						630 ... 9.8(10)						800 ... 10						1000 ... 10						1250 ... 10						1600 ... 10					
		75	4	4	3	3	3	3	4	4	3	3	3	3	4	4	3	3	3	3	4	4	3	3	3	3	4	4	3	3	3	3	4	4	3	3	3	3
		100	6	4	4	3	3	3	6	4	4	3	3	3	6	4	4	3	3	3	6	4	4	3	3	3	6	4	4	3	3	3	6	4	4	3	3	3
NF100-SP	30		Selective limit current																																			
		60	In=500 ... 7(30)						630 ... 9(30)						800 ... 14.5(30)						1000 ... 20(30)						1250 ... 25(30)						1600 ... 30					
		75	4	4	3	3	3	3	4	4	3	3	3	3	4	4	3	3	3	3	4	4	3	3	3	3	4	4	3	3	3	3	4	4	3	3	3	3
		100	6	4	4	3	3	3	6	4	4	3	3	3	6	4	4	3	3	3	6	4	4	3	3	3	6	4	4	3	3	3	6	4	4	3	3	3
NF100-SP T/A	30		Selective limit current																																			
		63 ~ 80	In=500 ... 7(30)						630 ... 9(30)						800 ... 14.5(30)						1000 ... 20(30)						1250 ... 25(30)						1600 ... 30					
		80 ~ 100	6	4	3	3	3	3	6	4	3	3	3	3	6	4	3	3	3	3	6	4	3	3	3	3	6	4	3	3	3	3	6	4	3	3	3	3
NF100-HP	50		Selective limit current																																			
		60	In=500 ... 11.2(50)						630 ... 16(50)						800 ... 30(50)						1000 ... 50						1250 ... 50						1600 ... 50					
		75	4	4	3	3	3	3	4	4	3	3	3	3	4	4	3	3	3	3	4	4	3	3	3	3	4	4	3	3	3	3	4	4	3	3	3	3
		100	6	4	4	3	3	3	6	4	4	3	3	3	6	4	4	3	3	3	6	4	4	3	3	3	6	4	4	3	3	3	6	4	4	3	3	3
NF100-HP T/A	50		Selective limit current																																			
		63 ~ 80	In=500 ... 11.2(50)						630 ... 16(50)						800 ... 30(50)						1000 ... 50						1250 ... 50						1600 ... 50					
		80 ~ 100	6	4	3	3	3	3	6	4	3	3	3	3	6	4	3	3	3	3	6	4	3	3	3	3	6	4	3	3	3	3	6	4	3	3	3	3
NF100-SEP	25		Selective limit current																																			
		60	In=500 ... 7(25)						630 ... 9(25)						800 ... 14.5(25)						1000 ... 20(25)						1250 ... 25						1600 ... 25					
		75	3	3	3				3	3	3				3	3	3				3	3	3				3	3	3				3	3	3			
		100	4	4	3	3	3	3	4	4	3	3	3	3	4	4	3	3	3	3	4	4	3	3	3	3	4	4	3	3	3	3	4	4	3	3	3	3
NF160-SP	25		Selective limit current																																			
		125	In=500 ... 6(25)						630 ... 7(25)						800 ... 11(25)						1000 ... 14(25)						1250 ... 19(25)						1600 ... 25					
		150	8	6	6	6	4	4	8	6	6	6	6	4	8	6	6	6	6	4	8	6	6	6	6	4	8	6	6	6	6	4	8	6	6	6	6	4
		160	10	8	8	6	6	6	10	8	8	6	6	6	10	8	8	6	6	6	10	8	8	6	6	6	10	8	8	6	6	6	10	8	8	6	6	6
NF160-SP T/A	25		Selective limit current																																			
		100 ~ 125	In=500 ... 6(25)						630 ... 7(25)						800 ... 11(25)						1000 ... 14(25)						1250 ... 19(25)						1600 ... 25					
		125 ~ 160	6	6	6	4	4	3	6	6	6	4	4	3	6	6	6	4	4	3	6	6	6	4	4	3	6	6	6	4	4	3	6	6	6	4	4	3
NF160-HP	50		Selective limit current																																			
		125	In=500 ... 7(50)						630 ... 9(50)						800 ... 12(50)						1000 ... 15(50)						1250 ... 25(50)						1600 ... 42(50)					
		150	8	6	6	6	4	4	8	6	6	6	6	4	8	6	6	6	6	4	8	6	6	6	6	4	8	6	6	6	6	4	8	6	6	6	6	4
		160	10	8	8	6	6	6	10	8	8	6	6	6	10	8	8	6	6	6	10	8	8	6	6	6	10	8	8	6	6	6	10	8	8	6	6	6
NF160-HP T/A	50		Selective limit current																																			
		100 ~ 125	In=500 ... 7(50)						630 ... 9(50)						800 ... 12(50)						1000 ... 15(50)						1250 ... 25(50)						1600 ... 42(50)					
		125 ~ 160	6	6	6	4	4	3	6	6	6	4	4	3	6	6	6	4	4	3	6	6	6	4	4	3	6	6	6	4	4	3	6	6	6	4	4	3
NC250-CP	15		Selective limit current																																			
		125	In=500 ... 7.5(15)						630 ... 9.4(15)						800 ... 12(15)						1000 ... 15						1250 ... 15						1600 ... 15					
		150	8	6	6	6	4	4	8	6	6	6	6	4	8	6	6	6	6	4	8	6	6	6	6	4	8	6	6	6	6	4	8	6	6	6	6	4
		175		10	8	8	6	6		10	8	8	6	6		10	8	8	6	6		10	8	8	6	6		10	8	8	6	6		10	8	8	6	6
		200			8	8	8	6			8	8	8	6			8	8	8	6			8	8	8	6			8	8	8	6			8	8	8	6
		225			10	8	8	8			10	8	8	8			10	8	8	8			10	8	8	8			10	8	8	8			10	8	8	8
NF250-CP T/A	15		Selective limit current																																			
		100 ~ 125	In=500 ... 7.5(15)						630 ... 9.4(15)						800 ... 12(15)						1000 ... 15						1250 ... 15						1600 ... 15					
		125 ~ 160	6	6	6	4	4	3	6	6	6	4	4	3	6	6	6	4	4	3	6	6	6	4	4	3	6	6	6	4	4	3	6	6	6	4	4	3
		150 ~ 200	10	8	8	6	6	6	10	8	8	6	6	6	10	8	8	6	6	6	10	8	8	6	6	6	10	8	8	6	6	6	10	8	8	6	6	6
200 ~ 250		10	8	8	6	6		10	8	8	6	6		10	8	8	6	6		10	8	8	6	6		10	8	8	6	6		10	8	8	6	6		

Icu: Rated breaking capacity

Main Breaker		Type	AE2000-SS					AE2500-SS					AE3200-SS					AE4000-SSC													
Branch Breaker		Ics(kA)	85					85					85					85													
Type	Icu(kA)	Rated current (A)	1000	1200	1400	1600	1800	2000	1250	1500	1750	2000	2250	2500	1600	1920	2240	2560	2880	3200	3200	3600	4000								
NF100-CP	10		Selective limit current																												
		60	In=1000 ... 10					1600 ... 10					2000 ... 10					2500 ... 10					3200 ... 10					4000 ... 10			
		75																													
		100																													
NF100-SP	30		Selective limit current																												
		60	In=1000 ... 20(30)					1600 ... 30					2000 ... 30					2500 ... 30					3200 ... 30					4000 ... 30			
		75																													
		100																													
NF100-SP T/A	30		Selective limit current																												
		63 ~ 80	In=1000 ... 20(30)					1600 ... 30					2000 ... 30					2500 ... 30					3200 ... 30					4000 ... 30			
		80 ~ 100																													
NF100-HP	50		Selective limit current																												
		60	In=1000 ... 50					1600 ... 50					2000 ... 50					2500 ... 50					3200 ... 50					4000 ... 50			
		75																													
		100																													
NF100-HP T/A	50		Selective limit current																												
		63 ~ 80	In=1000 ... 50					1600 ... 50					2000 ... 50					2500 ... 50					3200 ... 50					4000 ... 50			
		80 ~ 100																													
NF100-SEP	25		Selective limit current																												
		60	In=1000 ... 20(25)					1600 ... 25					2000 ... 25					2500 ... 25					3200 ... 25					4000 ... 25			
		75																													
		100																													
NF100-HEP	50		Selective limit current																												
		60	In=1000 ... 50					1600 ... 50					2000 ... 50					2500 ... 50					3200 ... 50					4000 ... 50			
		75																													
		100																													
NF160-SP	25		Selective limit current																												
		125	In=1000 ... 14(25)					1600 ... 25					2000 ... 25					2500 ... 25					3200 ... 25					4000 ... 25			
		150	3										3																		
		160	3	3	3								3																		
NF160-SP T/A	25		Selective limit current																												
		100 ~ 125	In=1000 ... 14(25)					1600 ... 25					2000 ... 25					2500 ... 25					3200 ... 25					4000 ... 25			
		125 ~ 160																													
NF160-HP	50		Selective limit current																												
		125	In=1000 ... 15(50)					1600 ... 42(50)					2000 ... 50					2500 ... 50					3200 ... 50					4000 ... 50			
		150	3										3																		
		160	3	3	3								3																		
NF160-HP T/A	50		Selective limit current																												
		100 ~ 125	In=1000 ... 15(50)					1600 ... 42(50)					2000 ... 50					2500 ... 50					3200 ... 50					4000 ... 50			
		125 ~ 160																													
NC250-CP	15		Selective limit current																												
		125	In=1000 ... 15					1600 ... 15					2000 ... 15					2500 ... 15					3200 ... 15					4000 ... 15			
		150	3										3																		
		175	4	3	3								3	3																	
		200	4	3	3	3							3	3	3						3										
		225	4	4	3	3	3						4	3	3						3	3									
		250	4	3	3								3	3																	
NF250-CP T/A	15		Selective limit current																												
		100 ~ 125	In=1000 ... 15					1600 ... 15					2000 ... 15					2500 ... 15					3200 ... 15					4000 ... 15			
		125 ~ 160																													
		150 ~ 200	3	3									3																		
		200 ~ 250	4	3	3								3	3																	

Icu: Rated breaking capacity

SELECTIVE-INTERRUPTION COMBINATIONS (DISCRIMINATION) 440VAC (Sym. kA)

Main Breaker Branch Breaker		Type	AE630-SS						AE1000-SS						AE1250-SS						AE1600-SS																		
		Ics(kA)	65						65						65						65																		
Type	Icu(kA)	Rated current (A)	315	378	441	504	567	630	500	600	700	800	900	1000	625	750	875	1000	1125	1250	800	960	1120	1280	1440	1600													
NF250-SP	25		Selective limit current																																				
		125	In=500 ... 6(25)						630 ... 7(25)						800 ... 11(25)						1000 ... 14(25)						1250 ... 19(25)						1600 ... 25						
		150	8	6	6	6	4	4	6	4	4	4	3	3	3	4	3	3	3	4	3	3	3	3	3	3	3	4	3	3	3	3	3	3	3				
		175	10	8	8	6	6	6	8	6	6	6	4	4	4	6	6	4	4	3	3	4	4	3	3	3	3	4	4	3	3	3	3	3	3				
		200		8	8	8	6	6	8	6	6	6	6	4	4	6	6	6	4	4	3	3	6	6	6	4	4	3	3	6	4	4	3	3	3	3	3		
		225		10	8	8	8	8	8	8	6	6	6	4	4	8	6	6	4	4	4	4	6	6	4	4	3	3	4	4	3	3	3	3	3	3			
		250	10	8	8	6	6	8	6	6	6	4	4	4	4	6	6	4	4	3	3	4	4	3	3	3	3	4	4	3	3	3	3	3	3				
NF250-SP T/A	25		Selective limit current																																				
		100 ~ 125	In=500 ... 6(25)						630 ... 7(25)						800 ... 11(25)						1000 ... 14(25)						1250 ... 19(25)						1600 ... 25						
		125 ~ 160	6	6	6	4	4	3	4	3	3	3			3	3	3				3						3												
		150 ~ 200	6	6	6	4	4	3	4	3	3	3			3	3	3				3						3												
		200 ~ 250	10	8	8	6	6	6	6	6	4	4	3	3	6	4	4	3	3	3	6	4	4	3	3	3	4	3	3	3	3	3	3	3					
		10	8	8	6	6	8	6	6	6	4	4	6	6	4	4	3	3	4	4	3	3	3	3	4	4	3	3	3	3	3	3							
NF250-HP	50		Selective limit current																																				
		125	In=500 ... 7(50)						630 ... 9(50)						800 ... 12(50)						1000 ... 15(50)						1250 ... 25(50)						1600 ... 42(50)						
		150	8	6	6	6	4	4	6	4	4	4	3	3	3	4	3	3	3	4	3	3	3	4	3	3	3	3	3	3	3	3	3	3	3				
		175	10	8	8	6	6	6	8	6	6	6	4	4	4	6	6	4	4	3	3	4	4	3	3	3	3	4	4	3	3	3	3	3	3				
		200		8	8	8	6	6	8	6	6	6	6	4	4	6	6	6	4	4	3	3	6	6	6	4	4	3	3	6	4	4	3	3	3	3	3		
		225		10	8	8	8	8	8	8	6	6	6	4	4	8	6	6	4	4	4	4	6	6	4	4	3	3	4	4	3	3	3	3	3	3			
		250	10	8	8	6	6	8	6	6	6	6	4	4	6	6	4	4	3	3	4	4	3	3	3	3	4	4	3	3	3	3	3	3					
NF250-HP T/A	50		Selective limit current																																				
		100 ~ 125	In=500 ... 7(50)						630 ... 9(50)						800 ... 12(50)						1000 ... 15(50)						1250 ... 25(50)						1600 ... 42(50)						
		125 ~ 160	6	6	6	4	4	3	4	3	3	3			3	3	3				3						3												
		150 ~ 200	6	6	6	4	4	3	4	3	3	3			3	3	3				3						3												
		200 ~ 250	10	8	8	6	6	6	6	6	4	4	3	3	6	4	4	3	3	3	6	4	4	3	3	3	4	3	3	3	3	3	3	3					
		10	8	8	6	6	8	6	6	6	4	4	6	6	4	4	3	3	4	4	3	3	3	3	4	4	3	3	3	3	3	3							
NF250-SEP	25		Selective limit current																																				
		125	In=500 ... 6(25)						630 ... 7(25)						800 ... 11(25)						1000 ... 14(25)						1250 ... 19(25)						1600 ... 25						
		150	6	6	6	4	4	3	4	3	3	3			3	3	3				3						3												
		175	8	6	6	6	4	4	6	4	4	3	3	3	4	3	3	3	4	3	3	3	3	3	3	3	3	3	3	3	3	3	3	3					
		200	8	8	6	6	6	4	6	6	4	4	3	3	4	4	3	3	4	4	3	3	3	3	3	3	4	3	3	3	3	3	3	3					
		225	10	8	8	6	6	6	6	6	4	4	3	3	6	4	4	3	3	3	6	4	4	3	3	3	4	3	3	3	3	3	3	3					
		250	10	10	8	8	6	6	8	6	6	4	4	4	6	6	4	4	3	3	4	4	3	3	3	3	4	4	3	3	3	3	3	3					
NF400-CP	25		Selective limit current																																				
		250	In=500 ... -						630 ... 9.4(25)						800 ... 12(25)						1000 ... 15(25)						1250 ... 18(25)						1600 ... 24(25)						
		300						6	6			6	6	4	4	4	6	6	4	4	3	3	4	4	3	3	3	3	4	4	3	3	3	3	3	3			
		350										6	6	6	6			6	6	4	4	4	4	6	6	4	4	3	3	4	4	3	3	3	3	3	3		
		400										6	6					6	6					6	6	6				6	6	6				6	6	4	4
NF400-SP	42		Selective limit current																																				
		250	In=500 ... -						630 ... 9.4(42)						800 ... 12(42)						1000 ... 15(42)						1250 ... 18(42)						1600 ... 24(42)						
		300						8	8			8	8	8	6	6	8	6	6	6	4	4	8	6	4	4	4	4	3	3	3	3	3	3					
		350										8	8	6	6			8	8	6	6	6	6	8	6	6	6	6	4	4	4	4	4	4	4				
		400										8	8					8	8	6	6	6	6	8	8	6	6	8	8	8	8	8	8	8	8	8			
NF400-SEP	42		Selective limit current																																				
		200	In=500 ... 7.5(42)						630 ... 9.4(42)						800 ... 12(42)						1000 ... 15(42)						1250 ... 18(42)						1600 ... 24(42)						
		225						6	6	4	4	6	6	4	4	3	3	4	4	3	3	3	3	4	4	3	3	3	3	3	3	3	3	3	3				
		250						8	6	6	8	6	6	6	4	4	4	6	6	4	4	3	3	4	4	4	3	3	4	4	4	3	3	3	3				
		300						8	8	6	8	8	6	6	6	6	6	4	6	6	6	4	4	3	3	6	4	4	3	3	6	4	4	3	3	3	3		
		350						8	8		8	8	6	6	8	6	6	6	8	6	6	6	4	4	3	3	6	6	6	4	4	6	4	4	3	3	3	3	
		400						8			8	8	6	6	8	8	6	6	8	8	6	6	6	4	4	8	6	6	6	6	4	4	8	6	6	4	4	4	4
NF400-HEP	65		Selective limit current																																				
		200	In=500 ... 7.5(65)						630 ... 9.4(65)						800 ... 12(65)						1000 ... 15(65)						1250 ... 18(65)						1600 ... 24(65)						
		225						6	6	4	4	6	6	4	4	3	3	4	4	3	3	3	3	4	4	3	3	3	3	3	3	3	3	3	3				
		250						8	6	6	8	6	6	6	4	4	4	6	6	4	4	3	3	4	4	4	3	3	4	4	4	3	3	3	3				
		300						8	8	6	8	8	6	6	6	6	6	4	6	6	6	4	4	3	3	6	6	6	4	4	3	6	4	4	3	3	3	3	
		350						8	8		8	8	6	6	8	6	6	6	8	6	6	6	4	4	3	3	6	6	6	4	4	6	6	4	4	3	3	3	3
		400						8			8	8	6	6	8	8	6	6	8	8	6	6	6	4	4	8	6	6	6	6	4	4	8	6	6	4	4	4	4

Icu: Rated breaking capacity

Main Breaker		Type	AE2000-SS						AE2500-SS					AE3200-SS					AE4000-SSC												
Branch Breaker		Ics(kA)	85						85					85					85												
Type	Icu(kA)	Rated current (A)	1000	1200	1400	1600	1800	2000	1250	1500	1750	2000	2250	2500	1600	1920	2240	2560	2880	3200	3200	3600	4000								
NF250-SP	25		Selective limit current																												
		125	In=1000 ... 14(25)						1600 ... 25					2000 ... 25					2500 ... 25					3200 ... 25				4000 ... 25			
		150	3	3					3																						
		175	4	3	3				3	3																					
		200	4	3	3	3			3	3	3										3										
		225	4	4	3	3	3	3	4	3	3										3	3									
250	4	3	3				3	3																							
NF250-SP T/A	25		Selective limit current																												
		100 ~ 125	In=1000 ... 14(25)						1600 ... 25					2000 ... 25					2500 ... 25					3200 ... 25				4000 ... 25			
		125 ~ 160																													
		150 ~ 200	3	3					3																						
200 ~ 250	4	3	3				3	3																							
NF250-HP	50		Selective limit current																												
		125	In=1000 ... 15(50)						1600 ... 42(50)					2000 ... 50					2500 ... 50					3200 ... 50				4000 ... 50			
		150	3	3					3																						
		175	4	3	3				3	3																					
		200	4	3	3	3			3	3	3										3										
		225	4	4	3	3	3	3	4	3	3										3	3									
250	4	3	3				3	3																							
NF250-HP T/A	50		Selective limit current																												
		100 ~ 125	In=1000 ... 15(50)						1600 ... 42(50)					2000 ... 50					2500 ... 50					3200 ... 50				4000 ... 50			
		125 ~ 160																													
		150 ~ 200	3	3					3																						
200 ~ 250	4	3	3				3	3																							
NF250-SEP	25		Selective limit current																												
		125	In=1000 ... 14(25)						1600 ... 25					2000 ... 25					2500 ... 25					3200 ... 25				4000 ... 25			
		150																													
		175	3																												
		200	3	3					3																						
		225	3	3					3																						
250	4	3	3				3	3																							
NF250-HEP	50		Selective limit current																												
		125	In=1000 ... 14(25)						1600 ... 25					2000 ... 25					2500 ... 25					3200 ... 25				4000 ... 25			
		150																													
		175	3																												
		200	3	3					3																						
		225	3	3					3																						
250	4	3					3	3																							
NF400-CP	25		Selective limit current																												
		250	In=1000 ... 15(25)						1600 ... 24(25)					2000 ... 25					2500 ... 25					3200 ... 25				4000 ... 25			
		300	4	4	3	3	3		4	3	3										3										
		350	6	4	4	3	3	3	4	3	3	3									3	3									
		400	6	6	4	4	3	3	6	4	3	3	3	3	4	3	3				4	3	3								
NF400-SP	42		Selective limit current																												
		250	In=1000 ... 15(42)						1600 ... 24(42)					2000 ... 30(42)					2500 ... 39(42)					3200 ... 42				4000 ... 42			
		300	6	4	4	3	3	3	4	3	3										3	3									
		350	8	6	6	4	4	4	6	6	4	3	3								4	4	3	3	3						
		400	8	6	6	6	4	4	6	6	4	4	3	3	4	3	3	3	3	6	4	4	3	3							
NF400-SEP	42		Selective limit current																												
		200	In=1000 ... 15(42)						1600 ... 24(42)					2000 ... 30(42)					2500 ... 39(42)					3200 ... 42				4000 ... 42			
		225	3	3					3																						
		250	4	3	3				3	3																					
		300	4	4	3	3	3		3	3	3										3										
		350	6	4	4	3	3	3	4	3	3	3									3	3									
400	6	4	4	4	3	3	4	3	3	3	3								4	3	3										
NF400-HEP	65		Selective limit current																												
		200	In=1000 ... 15(65)						1600 ... 24(65)					2000 ... 30(65)					2500 ... 39(65)					3200 ... 48(65)				4000 ... 62(65)			
		225	3	3					3																						
		250	4	3	3				3	3																					
		300	4	4	3	3	3		3	3	3										3	3									
		350	6	4	4	3	3	3	4	3	3	3									3	3									
400	6	4	4	4	3	3	4	3	3	3	3								4	4	3										

Icu: Rated breaking capacity

SELECTIVE-INTERRUPTION COMBINATIONS (DISCRIMINATION) 440VAC (Sym. kA)

Main Breaker Branch Breaker		Type	AE630-SS						AE1000-SS						AE1250-SS						AE1600-SS																	
		Ics(kA)	65						65						65						65																	
Type	Icu(kA)	Rated current (A)	315	378	441	504	567	630	500	600	700	800	900	1000	625	750	875	1000	1125	1250	800	960	1120	1280	1440	1600												
NF630-CP	50		Selective limit current																																			
		500	In=500 ---- -						630 ---- -						800 ---- -						1000 ---- -						1250 ---- 18.7(50)						1600 ---- 24(50)					
		600																									6	6					6	6	6	4		
		630																																	6	6		
NF630-SP	50		Selective limit current																																			
		500	In=500 ---- -						630 ---- -						800 ---- -						1000 ---- -						1250 ---- 18.7(50)						1600 ---- 24(50)					
		600																																				
		630																																	8	8		
NF630-SEP	85		Selective limit current																																			
		300	In=500 ---- 7.5(65)						630 ---- 9.4(65)						800 ---- 12(65)						1000 ---- 15(65)						1250 ---- 18.7(65)						1600 ---- 24(65)					
		350				8	8	6		8	8	6	6	4	6	6	6	6	4	4	4	6	6	6	4	4	4	6	6	4	4	4	4	6	6	4	4	
		400					8		10	8	8	6	6	8	8	6	6	8	8	6	6	6	6	6	4	4	4	8	6	6	4	4	4	8	6	6	4	
		500										10	10	8				8	8	6	6	10	10	6	6	6	6	10	6	6	6	4	6	6	6	4		
		600											10	8				8	8	6	6		10	10	6	6	6	8	8	6	6	4	8	6	6	4		
630												8				8	8	8				8	6	6			8	6	6	6	8	6	6	6				
NF630-HEP	100		Selective limit current																																			
		300	In=500 ---- -						630 ---- 9.4(65)						800 ---- 12(65)						1000 ---- 15(65)						1250 ---- 18.7(65)						1600 ---- 24(65)					
		350				8	8	6		8	8	6	6	4	6	6	6	6	4	4	4	6	6	6	4	4	4	6	6	4	4	4	4	6	6	4	4	
		400					8		10	8	8	6	6	8	8	6	6	8	8	6	6	6	6	6	4	4	4	8	6	6	4	4	4	8	6	6	4	
		500										10	10	8				8	8	6	6	10	10	6	6	6	6	10	6	6	6	4	6	6	6	4		
		600											10	8				8	8	6	6		10	10	6	6	6	8	8	6	6	4	8	6	6	4		
630												8				8	8	8				8	6	6			8	6	6	6	8	6	6	6				
NF800-CEP	50		Selective limit current																																			
		400	In=500 ---- -						630 ---- -						800 ---- 12(50)						1000 ---- 15(50)						1250 ---- 18.7(50)						1600 ---- 24(50)					
		450										8	8	6	6	6	6	6	6	6	4	8	6	6	6	4	4	8	6	6	4	4	4	8	6	6	4	
		500										8	8	8				8	8	6	6	8	8	6	6	8	8	8	6	6	6	4	8	6	6	4		
		600											8				8	8	6	6		8	8	6	6	6	8	8	6	6	4	8	6	6	4			
		700																				8	8					8	8	6	6	4	8	6	6	4		
800																						8										8	8	8				
NF800-SEP	85		Selective limit current																																			
		400	In=500 ---- -						630 ---- -						800 ---- 12(65)						1000 ---- 15(65)						1250 ---- 18.7(65)						1600 ---- 24(65)					
		450										8	8	6	6	6	6	6	6	6	4	8	6	6	6	4	4	8	6	6	4	4	4	8	6	6	4	
		500										8	8	8				8	8	6	6	8	8	6	6	8	8	8	6	6	6	4	8	6	6	4		
		600											8				8	8	6	6		8	8	6	6	6	8	8	6	6	4	8	6	6	4			
		700																				8	8					8	8	6	6	4	8	6	6	4		
800																						8										8	8	8				
NF800-HEP	100		Selective limit current																																			
		400	In=500 ---- -						630 ---- -						800 ---- 12(65)						1000 ---- 15(65)						1250 ---- 18.7(65)						1600 ---- 24(65)					
		450										8	8	6	6	6	6	6	6	6	4	8	6	6	6	4	4	8	6	6	4	4	4	8	6	6	4	
		500										8	8	8				8	8	6	6	8	8	6	6	8	8	8	6	6	6	4	8	6	6	4		
		600											8				8	8	6	6		8	8	6	6	6	8	8	6	6	4	8	6	6	4			
		700																				8	8					8	8	6	6	4	8	6	6	4		
800																						8										8	8	8				

Icu: Rated breaking capacity

Main Breaker		Type	AE2000-SS						AE2500-SS						AE3200-SS						AE4000-SSC					
Branch Breaker		Ics(kA)	85						85						85						85					
Type	Icu(kA)	Rated current (A)	1000	1200	1400	1600	1800	2000	1250	1500	1750	2000	2250	2500	1600	1920	2240	2560	2880	3200	3200	3600	4000			
NF630-CP	50		Selective limit current																							
		500		6	6	4	4	4	6	6	6	4	4	4	4	4	4	4	4	4	4					
		600			6	6	6	4	8	6	6	6	4	4	4	6	4	4	4	4	4	4	4	4		
		630			6	6	6	6		6	6	6	4	4	6	6	4	4	4	4	4	4	4	4	4	4
NF630-SP	50		Selective limit current																							
		500		8	8	6	6	6	8	6	6	6	4	4	6	6	4	4	4	4	4	4	4	4	4	
		600			8	8	6	6		8	8	6	6	6	8	6	6	6	6	6	6	6	6	6	4	4
		630			10	8	8	6		8	8	6	6	6	8	6	6	6	6	6	6	6	6	6	4	4
NF630-SEP	85		Selective limit current																							
		300		4	4	4	4	4	4	4	4	4			4											
		350		6	4	4	4	4	4	4	4	4	4			4	4									
		400		6	6	4	4	4	4	4	4	4	4			4	4	4	4							
		500		8	6	6	4	4	4	6	6	4	4	4	4	4	4	4	4							
		600		8	8	6	6	6	4	6	6	6	4	4	4	6	4	4	4	4	4	4	4	4	4	
630		8	8	6	6	6	4	8	6	6	4	4	4	6	6	4	4	4	4	4	4	4	4			
NF630-HEP	100		Selective limit current																							
		300		4	4	4	4	4	4	4	4	4			4											
		350		6	4	4	4	4	4	4	4	4	4			4	4									
		400		6	6	4	4	4	4	4	4	4	4			4	4	4	4							
		500		8	6	6	4	4	4	6	6	4	4	4	4	4	4	4	4	4						
		600		8	8	6	6	6	4	6	6	6	4	4	4	6	4	4	4	4	4	4	4	4	4	
630		8	8	6	6	6	4	8	6	6	4	4	4	6	6	4	4	4	4	4	4	4	4			
NF800-CEP	50		Selective limit current																							
		400		6	6	4	4	4	4	4	4	4	4	4		4	4	4								
		450		6	6	4	4	4	4	6	4	4	4	4	4	4	4	4	4							
		500		8	6	6	4	4	4	6	6	4	4	4	4	4	4	4	4	4						
		600		8	8	6	6	6	4	6	6	6	4	4	4	6	4	4	4	4	4	4	4	4	4	
		700			8	8	6	6	6	8	6	6	6	4	4	6	6	4	4	4	4	4	4	4	4	
800			8	8	6	6	6	8	8	6	6	6	4	8	6	6	4	4	4	4	4	4	4			
NF800-SEP	85		Selective limit current																							
		400		6	6	4	4	4	4	4	4	4	4	4		4	4	4								
		450		6	6	4	4	4	4	6	4	4	4	4	4	4	4	4	4							
		500		8	6	6	4	4	4	6	6	4	4	4	4	4	4	4	4	4						
		600		8	8	6	6	6	4	6	6	6	4	4	4	6	4	4	4	4	4	4	4	4	4	
		700			8	8	6	6	6	8	6	6	6	4	4	6	6	4	4	4	4	4	4	4	4	
800			8	8	6	6	6	8	8	6	6	6	4	8	6	6	4	4	4	4	4	4	4			
NF800-HEP	100		Selective limit current																							
		400		6	6	4	4	4	4	4	4	4	4	4		4	4	4								
		450		6	6	4	4	4	4	6	4	4	4	4	4	4	4	4	4							
		500		8	6	6	4	4	4	6	6	4	4	4	4	4	4	4	4	4						
		600		8	8	6	6	6	4	6	6	6	4	4	4	6	4	4	4	4	4	4	4	4	4	
		700			8	8	6	6	6	8	6	6	6	4	4	6	6	4	4	4	4	4	4	4	4	
800			8	8	6	6	6	8	8	6	6	6	4	8	6	6	4	4	4	4	4	4	4			

Icu: Rated breaking capacity

6.4 Cascade Back-up Protection

6.4.1 Cascade Back-up Combinations

Following tables show the available MCCB combinations for cascade interruption and their interrupting capacity.

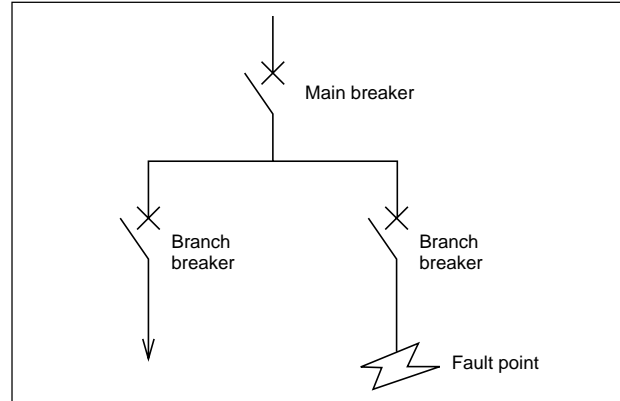

440VAC

Main MCCB		S																C				U										
		NF100-SP	NF100-HP	NF160-SP	NF160-HP	NF250-SP	NF250-HP	NF400-SP	NF400-HEP	NF400-REP	NF630-SP	NF630-HEP	NF630-REP	NF800-SEP	NF800-HEP	NF800-REP	NF1000-SS, NF1250-SS, NF1600-SS	NF2000-S, NF2500-S	NF3200-S, NF4000-S	NF250-CP	NF400-CP	NF630-CP	NF800-CEP	NF100-RP	NF100-UP	NF225-RP	NF225-UP	NF400-JEP	NF630-JEP	NF800-JEP	NF1250-UR	
Branch MCCB		25	50	25	50	25	50	50	65	125	50	65	125	50	65	125	85	85	85	15	25	35	35	125	200	125	200	200	200	200	200	125
S	NF30-SP	2.5	10	14	5	5	5	5	-	-	-	-	-	-	-	-	-	-	-	5	-	-	-	35	125	35	50	-	-	-	-	
	MB30-SP	2.5	10	14	5	5	5	5	-	-	-	-	-	-	-	-	-	-	-	5	-	-	-	35	125	35	50	-	-	-	-	
	MB50-CP	2.5	10	14	5	5	5	5	-	-	-	-	-	-	-	-	-	-	-	5	-	-	-	35	125	35	50	-	-	-	-	
	MB50-SP	7.5	14	20	15	10	15	10	15	10	10	10	10	10	10	10	10	10	10	-	10	10	-	50	125	50	50	10	10	10	10	
	NF50-HP	10	20	30	18	-	18	-	15	15	15	14	14	14	-	-	-	-	-	-	-	-	-	125	125	50	50	-	-	-	-	
	NF60-HP	10	20	30	18	-	18	-	15	15	15	14	14	14	-	-	-	-	-	-	-	-	-	125	125	50	50	-	-	-	-	
	NF50-HRP	30	-	50	-	42	-	42	-	-	-	-	-	-	-	-	-	-	-	-	-	-	-	125	200	125	200	200	85	85	-	
	NF100-SP	25	-	50	-	42	-	42	35	35	35	35	35	35	35	35	35	30	-	-	-	-	-	125	200	125	200	50	50	35	30	
	MB100-SP	25	-	50	-	42	-	42	35	35	35	35	35	35	35	35	30	-	-	-	-	-	-	125	200	125	200	50	50	35	30	
	NF100-HP	50	-	-	-	-	-	-	65	65	-	65	65	-	65	65	-	-	-	-	-	-	-	125	200	125	200	200	85	85	65	
	NF160-SP	25	-	-	-	-	-	-	35	50	50	50	35	50	50	35	50	50	-	-	-	-	-	-	125	200	85	85	85	-	-	
	NF160-HP	50	-	-	-	-	-	-	65	65	65	-	65	65	-	65	65	-	-	-	-	-	-	-	125	200	200	200	200	65	-	
	NF250-SP	25	-	-	-	-	-	-	35	50	50	35	50	50	35	50	50	-	-	-	-	-	-	-	125	200	85	85	85	-	-	
	MB225-SP	25	-	-	-	-	-	-	35	50	50	35	50	50	35	50	50	-	-	-	-	-	-	-	125	200	85	85	85	-	-	
NF250-HP	50	-	-	-	-	-	-	65	65	-	65	65	-	65	65	-	-	-	-	-	-	-	-	125	200	200	200	200	65	-		
NF400-SP	50	-	-	-	-	-	-	65	65	-	65	65	-	65	65	-	-	-	-	-	-	-	-	-	-	-	200	200	200	-		
NF400-SEP	50	-	-	-	-	-	-	65	65	-	65	65	-	65	65	-	-	-	-	-	-	-	-	-	-	-	200	200	200	-		
NF630-SP	50	-	-	-	-	-	-	-	-	-	-	65	65	-	65	65	-	-	-	-	-	-	-	-	-	-	-	200	200	-		
NF630-SEP	50	-	-	-	-	-	-	-	-	-	-	65	65	-	65	65	-	-	-	-	-	-	-	-	-	-	-	200	200	-		
C	NF50-CP	2.5	10	14	5	5	5	5	-	-	-	-	-	-	-	-	-	-	-	5	-	-	-	35	125	35	50	5	-	-	-	
	NF60-CP	2.5	10	14	5	5	5	5	-	-	-	-	-	-	-	-	-	-	-	5	-	-	-	35	125	35	50	5	-	-	-	
	NF100-CP	10	20	30	14	14	14	14	14	14	14	14	14	14	14	14	14	14	-	-	-	14	14	14	125	200	50	125	14	14	14	14
	NF250-CP	15	-	-	25	25	25	25	30	30	30	25	25	25	20	20	20	20	20	20	-	18	18	18	-	-	125	200	50	30	25	20
	NF400-CP	25	-	-	-	-	-	-	35	35	35	35	35	35	35	35	35	30	30	30	-	-	-	-	-	-	-	50	50	50	30	
NF630-CP	35	-	-	-	-	-	-	-	-	-	42	50	50	42	50	50	42	42	42	-	-	-	-	-	-	-	-	200	200	42		

230VAC

Main MCCB		Interrupting capacity (kA)		S															C				U										
				NF100-SP	NF100-HP	NF160-SP	NF160-HP	NF250-SP	NF250-HP	NF400-SP	NF400-HEP	NF400-REP	NF630-SP	NF630-HEP	NF630-REP	NF800-SEP	NF800-HEP	NF800-REP	NF100-SS, NF1250-SS, NF1600-SS	NF2000-S, NF2500-S	NF3200-S, NF4000-S	NF250-CP	NF400-CP	NF630-CP	NF800-CEP	NF100-RP	NF100-UP	NF225-RP	NF225-UP	NF400-UEP	NF630-UEP	NF800-UEP	NF1250-UR
Branch MCCB		50	100	50	100	50	100	85	100	125	85	100	125	85	100	125	125	125	125	30	50	50	50	125	200	125	200	200	200	200	200	200	170
S	NF30-SP	5	42	50	10	10	10	10	-	-	-	-	-	-	-	-	-	-	-	-	7.5	-	-	-	125	200	35	50	-	-	-	-	
	MB30-SP																																
	MB50-CP	10	42	85	35	35	35	35	30	30	30	30	30	30	-	-	-	-	-	-	25	14	14	-	125	200	85	125	-	-	-	-	
	NF50-HP	25	50	100	50	50	50	50	50	50	50	50	50	50	-	-	-	-	-	-	-	30	30	-	125	200	85	125	-	-	-	-	
	NF60-HP																																
	NF50-HRP	85	-	-	-	-	-	-	-	-	-	-	-	-	-	-	-	-	-	-	-	-	-	-	125	200	125	200	200	125	125	-	
	NF100-SP	50	-	100	-	85	-	85	85	85	85	85	85	85	85	-	-	-	-	-	-	-	-	-	125	200	125	200	200	125	125	-	
	MB100-SP																																
	NF100-HP	100	-	-	-	-	-	-	-	-	-	-	-	-	-	-	-	-	-	-	-	-	-	-	125	200	125	200	200	125	125	-	
	NF160-SP	50	-	-	-	85	-	85	85	85	85	85	85	85	70	70	70	70	-	-	-	-	-	-	-	-	-	125	200	200	125	125	70
	NF160-HP	100	-	-	-	-	-	-	-	-	-	-	-	-	-	-	-	-	-	-	-	-	-	-	-	-	-	125	200	200	200	200	-
	NF250-SP	50	-	-	-	85	-	85	85	85	85	85	85	85	70	70	70	70	-	-	-	-	-	-	-	-	-	125	200	200	125	125	70
	MB225-SP																																
NF250-HP	100	-	-	-	-	-	-	-	-	-	-	-	-	-	-	-	-	-	-	-	-	-	-	-	-	-	125	200	200	200	200	-	
NF400-SP	85	-	-	-	-	-	-	-	-	-	-	-	-	-	-	-	-	-	-	-	-	-	-	-	-	-	-	-	200	200	200	100	
NF400-SEP																																	
NF630-SP	85	-	-	-	-	-	-	-	-	-	-	-	-	-	-	-	-	-	-	-	-	-	-	-	-	-	-	-	-	200	200	100	
NF630-SEP																																	
C	NF50-CP	5	35	50	10	10	10	10	-	-	-	-	-	-	-	-	-	-	-	-	7.5	-	-	-	125	200	35	50	-	-	-	-	
	NF60-CP																																
	NF100-CP	25	35	85	50	50	50	50	50	50	50	50	50	50	-	-	-	-	-	-	-	30	30	-	125	200	85	125	50	50	-	-	
	NF250-CP	30	-	-	50	50	50	50	50	50	50	50	50	50	-	-	-	-	-	-	-	-	35	35	-	-	-	125	200	200	50	50	-
NF400-CP	35	-	-	-	-	-	85	85	85	85	85	85	85	85	85	85	85	85	85	85	-	-	-	-	-	-	-	-	200	200	200	85	
NF630-CP	50	-	-	-	-	-	-	-	-	-	85	85	85	85	85	85	85	85	85	85	-	-	-	-	-	-	-	-	-	200	200	85	

6.5 I²t let-Through and Current Limiting Characteristics

I²t let-through characteristics

Current limiting characteristics

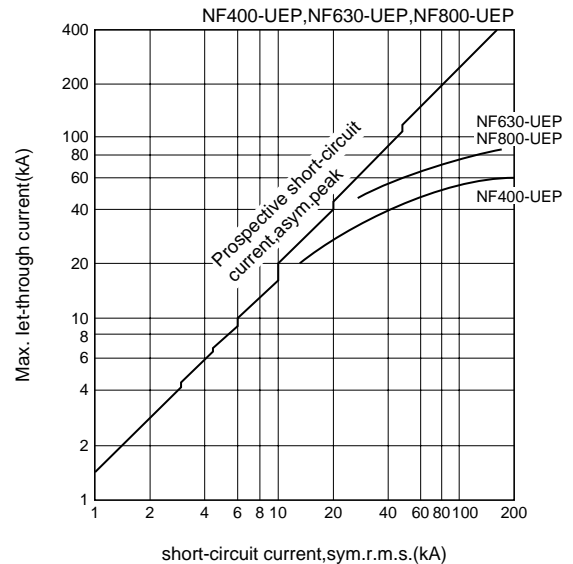
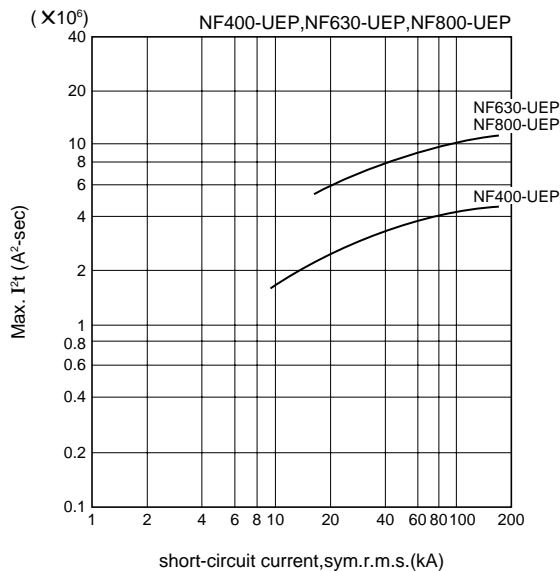
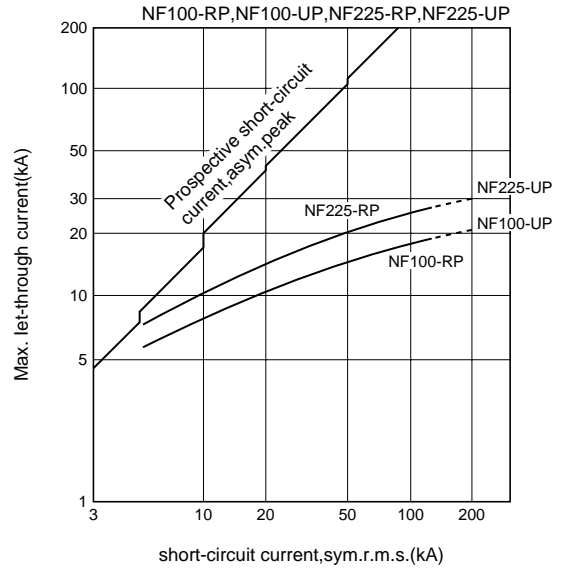
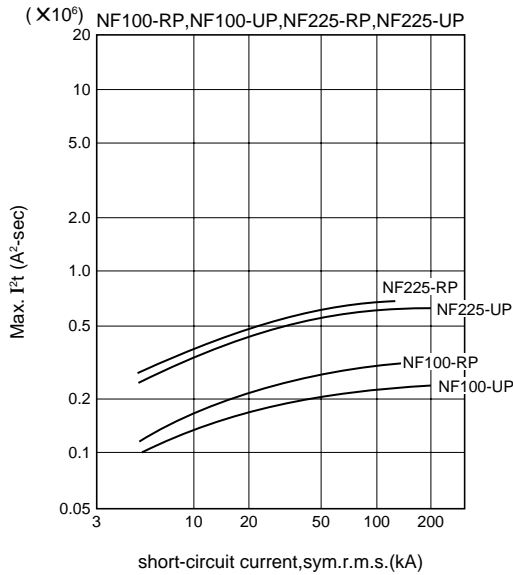
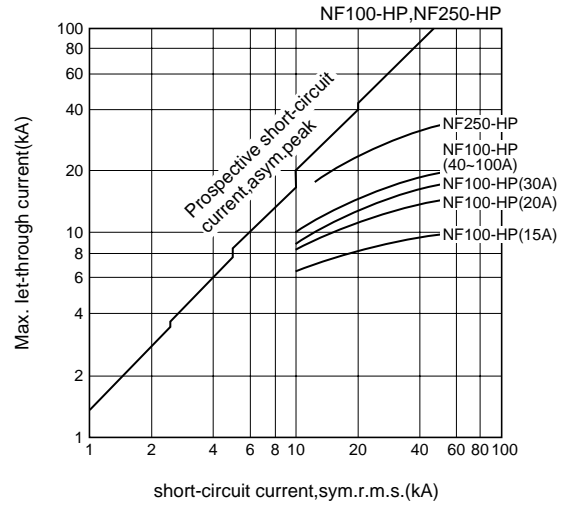
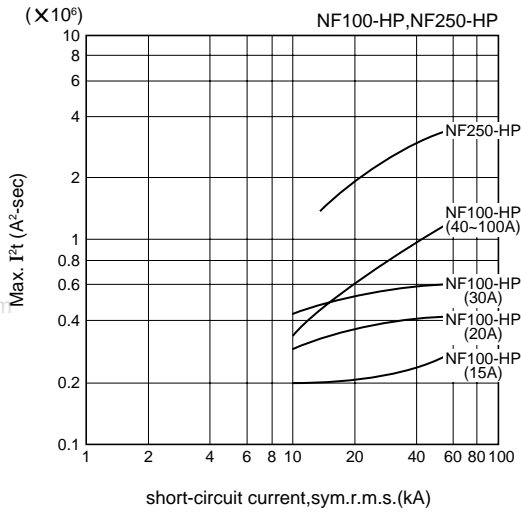

6.6 Protective Coordination with Wiring

6.6.1 General Considerations

If it is assumed that the heat generated by a large current passing through a wire is entirely dissipated within the wire, the following expression is applicable (for copper wires):

$$\left(\frac{I}{S}\right)^2 t = 5.05 \times 10^4 \log_e \frac{234+T}{234+T_0}$$

- I : Current(A, rms)
 S : Wire cross-sectional area(mm²)
 t : Current let-through time(sec)
 T : Wire temperature due to short circuit(°C)
 T₀ : Wire temperature before short circuit(°C)

Assume that short-circuit current occurs in a wire carrying its rated current (hot state T₀=60°C). If 150°C is the allowable temperature T, the following expression is applicable (see also Fig. 6.13):

Table 6.4 Allowable Fault Conditions in Conductors

S Wire size mm ²	Allowable I ² t A ² ×sec	I _s Allowable short-circuit current according to I ² t kA, sym. (PF)
1	0.014×10 ⁶	1.17 (0.9)
1.5	0.032×10 ⁶	1.76 (0.9)
2.5	0.088×10 ⁶	2.93 (0.9)
4	0.224×10 ⁶	4.68 (0.9)
6	0.504×10 ⁶	6.79 (0.8)
10	1.40×10 ⁶	10.5 (0.6)
16	3.58×10 ⁶	16.0 (0.5)
25	8.75×10 ⁶	17.3 (0.3)
35	17.2×10 ⁶	24.2 (0.3)
50	35.0×10 ⁶	34.5 (0.3)
70	68.6×10 ⁶	48.3 (0.3)
95	126×10 ⁶	65.6 (0.3)
120	202×10 ⁶	82.8 (0.3)
150	315×10 ⁶	103 (0.3)
185	479×10 ⁶	128 (0.3)
240	806×10 ⁶	166 (0.3)

- Notes: 1. Allowable I²t is calculated assuming that all heat energy is dissipated in the conductor, conductor allowable maximum temperature exceeds 150°C, and hot start is applied, at 60°C.
 2. I_s is an asym. value of allowable short-circuit current reduced to below the allowable I²t, assuming half cycle interruption for 16mm² or less and one cycle interruption for 25mm² or more.

$$\text{Allowable } I^2t = 14000S^2$$

Considering let-through energy ($\int i^2 dt$) in a fault where the protector has no current-limiting capability, if short-circuit occurs when let-through current is max., $\int i^2 dt$ is:

Approx. $\frac{I_e^2}{71}$ (A²·sec) in $\frac{1}{2}$ cycle interruption
 (Power factor is 0.5)
 Approx. $\frac{I_e^2}{34}$ (A²·sec) in 1 cycle interruption
 (Power factor is 0.3)

where current I_e is the effective value of the AC component. Half-cycle interruption is applied to wire of up to 14mm², and one-cycle interruption to larger wires. Table 6.4 is restrictive in that, e.g., in a circuit of fault capacity of 5000A or more, 2.5mm² wires would not be permitted. In practice, the impedance of the conductor itself presents a limiting factor, as does the inherent impedance of the MCCB, giving finite let-through I²t and I_p values that determine the actual fault-current flow.

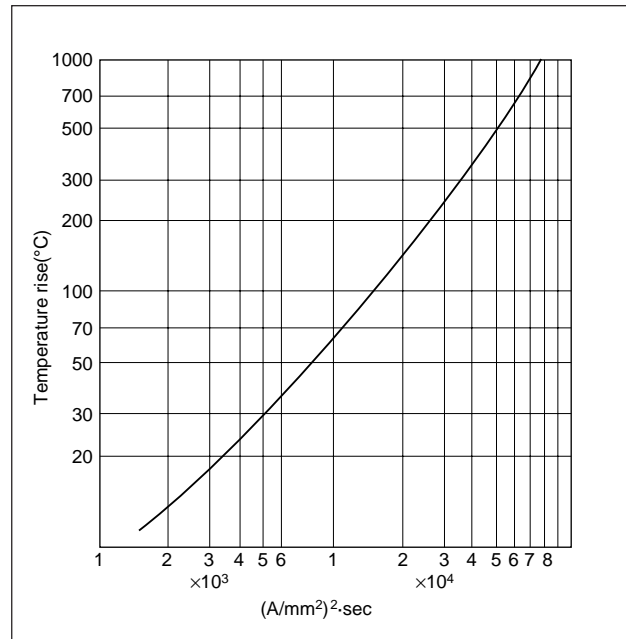

Fig. 6.13 Temperature Rises Due to Current Flow in Copper Wires

6.6.2 600V Vinyl-Insulated Wire (Overcurrent)

Japanese Electrical Installations Technical Standards (domestic) specify vinyl-insulated wire operating temperature as 60°C max., being a 30°C rise over a 30°C ambient temperature. This is to offset aging deterioration attendant on elevated temperatures over long periods. Criteria for elevated temperatures over short periods have been presented in a study by B. W. Jones and J. A. Scott ("Short-Time Current Ratings for Aircraft Wire and Cable," AIEE Transactions), which proposes 150°C for periods of up to 2 seconds, and 100°C for periods in the order of 20 seconds. These criteria can be transposed to currents for different wire sizes by the curves given in Fig. 6.14. Such figures, however, must be further compensated for the difference between vinyl materials used for aircraft and for

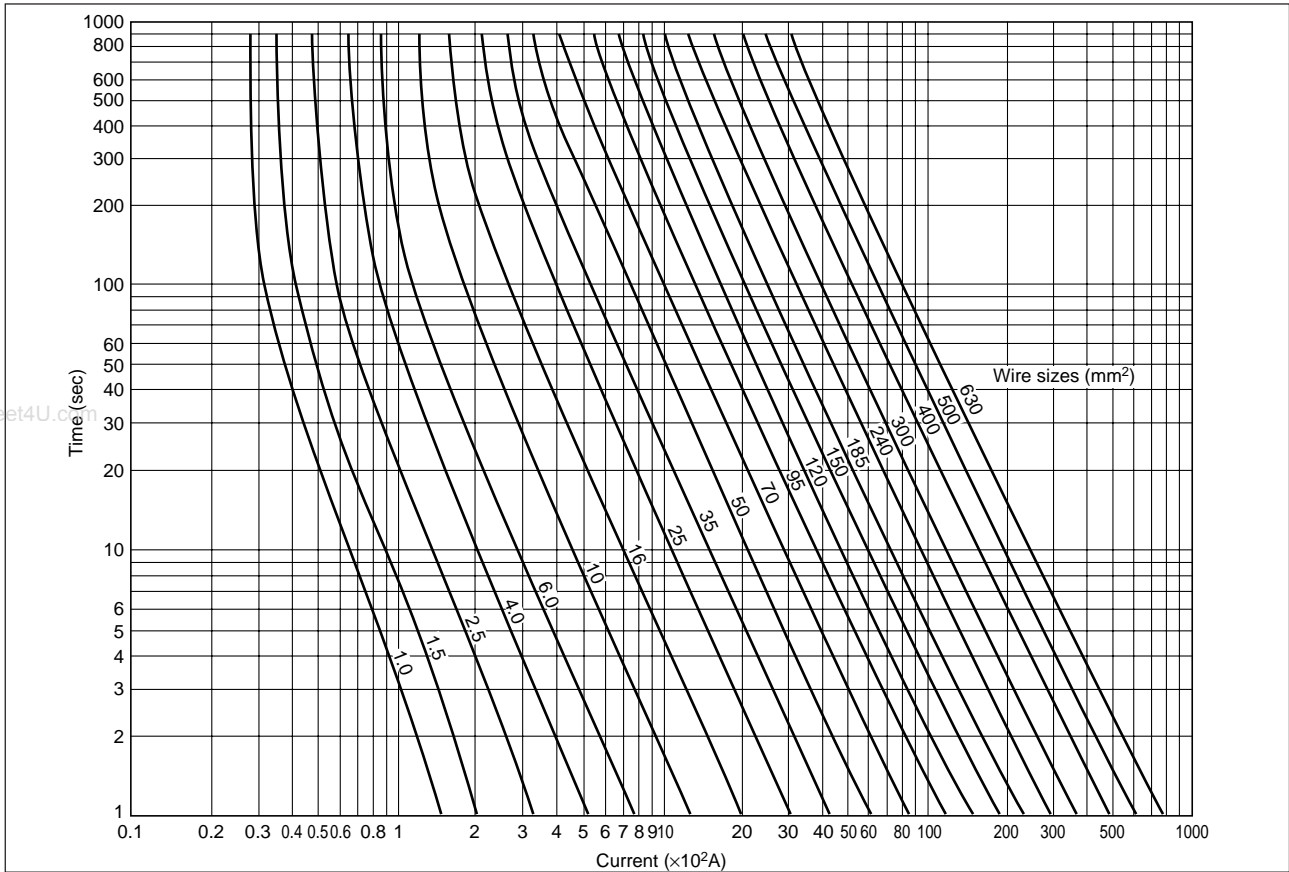

Fig. 6.14 Relation of Let-through Current to Time until 600V Vinyl-Insulated Wire Reaches a 70°C Temperature Rise. (In a Start from No Load State at Ambient Temperature of 30°C)

ground use; ultimately, the temperature figure of 75°C is derived (100°C per Jones and Scott, compensated) as a suitable short-time limitation for wiring with heat-proof vinyl or styrene-butadene-rubber insulation. Current transpositions for the range of wire sizes are not presented, being non-standard ; however, Fig. 6.15 gives MCCB ratings for temperature limitations of 30°C in normal operation, and 75°C for periods of up to 20

MCCB rating(A)	1	1.5	2.5	4	6	10	16	25	35	50	70	95	120	185	240	
15	Protected															
20	Protected	Protected														
30	Protected	Protected	Protected													
40	Protected	Protected	Protected	Protected												
50	Protected	Protected	Protected	Protected	Protected											
60	Protected	Protected	Protected	Protected	Protected	Protected										
75	Protected	Protected	Protected	Protected	Protected	Protected	Protected									
100	Protected	Protected	Protected	Protected	Protected	Protected	Protected	Protected								
125	Protected	Protected	Protected	Protected	Protected	Protected	Protected	Protected	Protected							
150	Protected	Protected	Protected	Protected	Protected	Protected	Protected	Protected	Protected	Protected						
175	Protected	Protected	Protected	Protected	Protected	Protected	Protected	Protected	Protected	Protected	Protected					
200	Protected	Protected	Protected	Protected	Protected	Protected	Protected	Protected	Protected	Protected	Protected	Protected				
225	Protected	Protected	Protected	Protected	Protected	Protected	Protected	Protected	Protected	Protected	Protected	Protected	Protected			
250	Protected	Protected	Protected	Protected	Protected	Protected	Protected	Protected	Protected	Protected	Protected	Protected	Protected	Protected		
300	Protected	Protected	Protected	Protected	Protected	Protected	Protected	Protected	Protected	Protected	Protected	Protected	Protected	Protected	Protected	
350	Protected	Protected	Protected	Protected	Protected	Protected	Protected	Protected	Protected	Protected	Protected	Protected	Protected	Protected	Protected	Protected
400	Protected	Protected	Protected	Protected	Protected	Protected	Protected	Protected	Protected	Protected	Protected	Protected	Protected	Protected	Protected	Protected

Fig. 6.15 MCCBs and Wiring Sizes

seconds.

The apparent disparity of the ambient ratings of 30°C for wiring against 40°C for MCCBs, is reconcilable in that wiring, for the most part, is externally routed, while MCCBs are housed in panelboards or the like. The two figures can be used compatibly, without modification. It is further noted that, where MCCBs with long-delay elements of the thermal type are employed, the effect of increased ambient, which would normally derate the wiring, is adequately compensated by the attendant decrease in thermal-region tripping time of the MCCB.

The curves in Fig. 6.17 show the comparison of the delay regions of MCCB tripping with allowable currents in open-routed wiring. Fig. 6.16 shows the method required by the Japanese standards referred to above, for derating wiring to be routed in conduit.

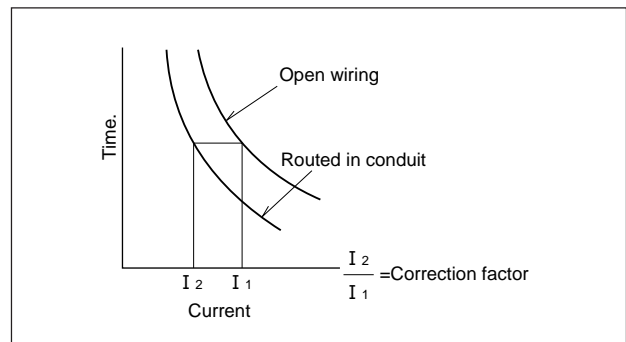
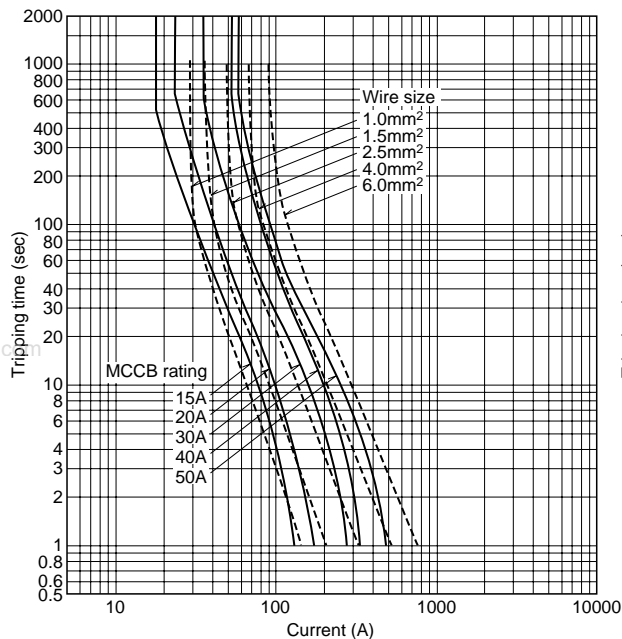
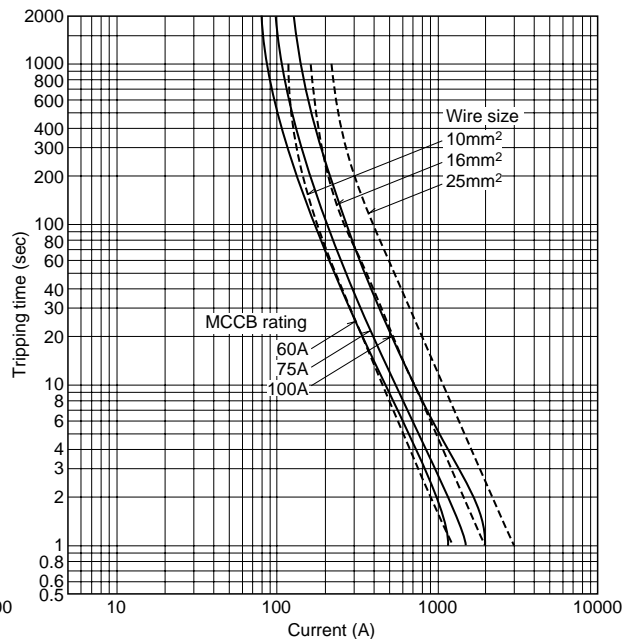

Fig. 6.16 Wire Derating Method, for Conduit Routing



a) 50A-fream MCCB



b) 100A-fream MCCB

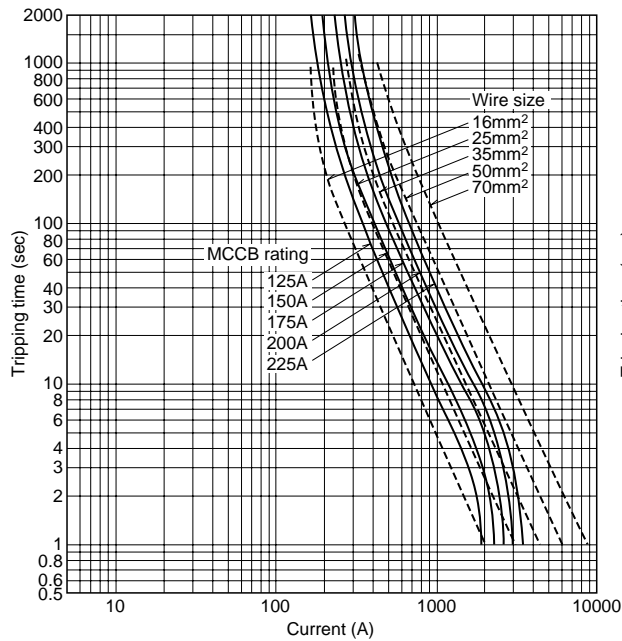

c) 225A-fream MCCB

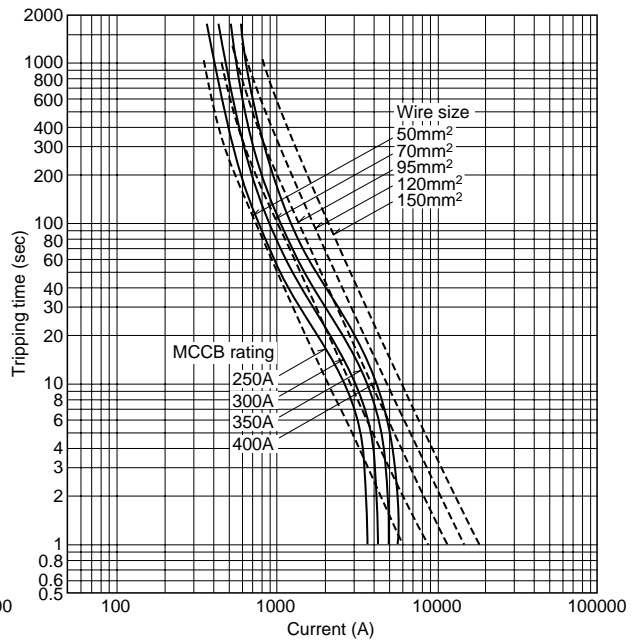

d) 400A-fream MCCB

Fig. 6.17 600V Wire and MCCB Protection Compatibility

6.7 Protective Coordination with Motor Starters

Motor starters comprise a magnetic contactor and a thermal overload relay, providing the necessary switching function for control of the motor, plus an automatic cutout function for overload protection. Mitsubishi Electric's excellent line of motor starters are available for a wide range of motor applications and are compatible with Mitsubishi MCCBs.

Magnetic contactors are rugged switching devices required to perform under severe load conditions without adverse affect. They are divided into Classes A through D (by capacity); Class A, e.g., must be able to perform 5 cycles of closing and opening of 10 times rated current, followed by 100 closing operations of the same current after grinding off 3/4 of the contact thickness.

Current ratings of contactors usually differ according to the circuit rated voltage, since voltage determines arc energy, which limits current-handling capability.

Thermal overload relays (OLRs) employ bimetal elements (adjustable) similar to those of MCCBs.

For compatibility with the magnetic contactor, the OLR must be capable of interrupting 10 times the motor

full-load current without destruction of its heater element. Mitsubishi Type TH OLRs are normally capable of handling 12 to 20 times rated current; in addition there is available a unique saturable reactor for parallel connection to the heaters of some types, giving a fusion-proofing effect of 40~50 times.

6.7.1 Basic Criteria for Coordination

It is necessary to ensure that the MCCB does not trip due to the normal starting current, but that the OLR cutout curve intersects the MCCB thermal delay-tripping curve between normal starting current and 10 times full-load current. The MCCB instantaneous-tripping setting should be low enough to protect the OLR heater element from fusion, in a short-circuit condition.

The above criteria should ensure that either the MCCB or the OLR will interrupt an overload, to protect the motor and circuit wiring, etc. In practice it is desirable for the MCCB instantaneous tripping to be set for about 15 times full-load current as a margin against transients, such as in reclosing after power failure, Y-delta switching, inching, etc.

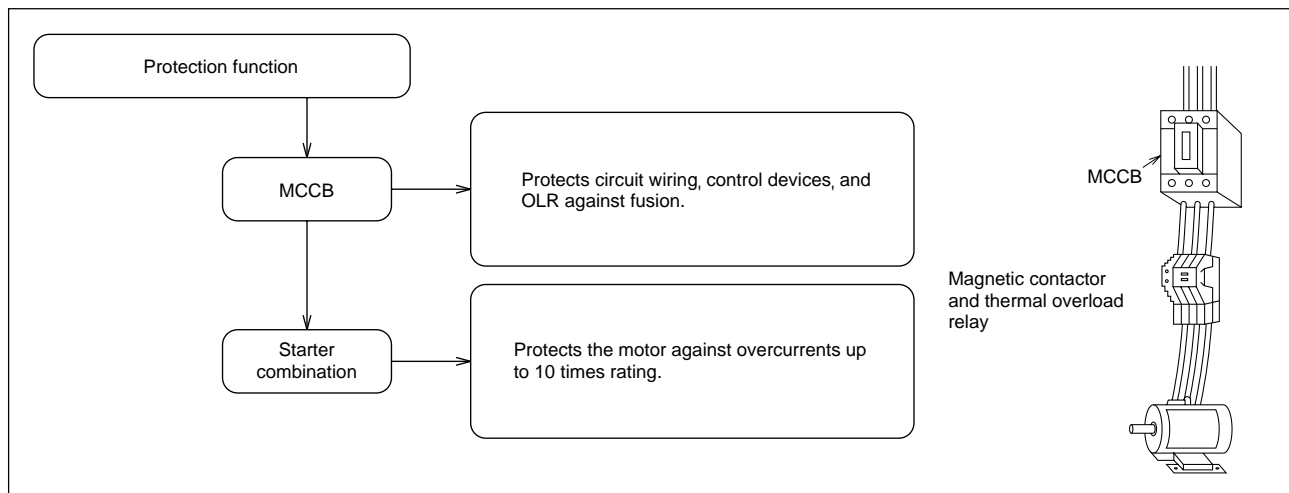

Fig. 6.18 Protective Coordination; MCCBs and Motor Starters

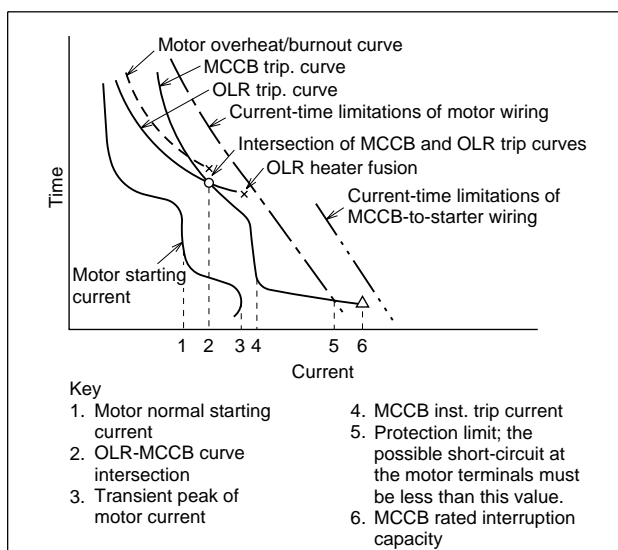

Fig. 6.19 Protection Coordination Criteria for MCCBs and Motor Starters

6.7.2 Levels of Protection (Short Circuit)

In some cases it may be advantageous to allow the starter to be damaged in the event of a short circuit, provided that the fault is interrupted and the load side is properly protected.

IEC standards defines 2 types of coordination, summarized as:

1. Type "1" coordination requires that, under short-circuit conditions, the contactor or starter shall cause no danger to persons or installation and may not be suitable for further service without repair and replacement of parts.
2. Type "2" coordination requires that, under short-circuit conditions, the contactor or starter shall cause no danger to persons or installation and shall be suitable for further use. The risk of contact welding is recognized, in which case the manufacturer shall indicate the measures to be taken as regards the maintenance of the equipment.

6.7.3 Motors with Long Starting Times

The usual approach is to select a starter with a larger current rating, but this method, of course, involves a degree of sacrifice of protection. Mitsubishi provides a unique solution to this problem in the form of a saturable reactor added to the OLR heater element. The effect is to change the high-current characteristics, so that nuisance tripping in starting is eliminated, without loss of overload protection. Mitsubishi saturable reactors are adjusted to allow around 25~30 seconds of continuous starting current.

6.7.4 Motor Breakers (M Line MCCBs) and Magnetic Contactors

M Line MCCBs are provided with trip curves especially suitable for motor protection, with ratings based on motor full-load currents. They provide overcurrent and short-circuit protection, and are normally used with magnetic contactors. The need for protective coordination (as with a regular MCCB plus a starter) is eliminated, and the reliability of protection in a short-circuit condition is far higher than that of the heater of a starter OLR. Where the motor starting time is long, the MCCB tripping curve must be checked carefully, since tripping times are rather short in the delay-trip range. Care must also be taken with respect to surge conditions such as inching, reversing, restart, Y-delta starting, etc.

6.7.5 Motor Thermal Characteristics

Overload currents in motors can lead to burnout, or insulation damage resulting in shock or fire hazard; the basic approaches to protection are (summarized from Japanese standards):

1. MCCB + magnetic contactor + OLR
2. Motor breaker + magnetic contactor
3. Motor breaker alone

In 1, the OLR is the primary interrupter of overload, and being adjustable, can be set for the true load requirement. Large overcurrent or short-circuit fault conditions are interrupted by the MCCB instantaneous trip. In 2, the motor breaker is the protector for both overload and short-circuit, and not being adjustable must be selected carefully, for best coordination with the load concerned. In 3, since the MCCB is relied on not only for all protective functions but also for switching, this arrangement should be reserved for applications requiring infrequent motor starting and stopping.

6.7.6 Motor Starting Current

Motor starting times of up to 15 seconds are generally considered safe; more than this is considered undesirable; more than 30 seconds is considered dangerous and should be avoided wherever possible. For instantaneous tripping considerations, the MCCB is normally set to 600% of the motor full-load current, for trouble-free line-starting of an induction motor. More detailed consideration is required where short-time inrush effects (current magnification) are involved, such as in Y-delta switching, running restart, etc. Two basic causations are as follows:

1. Superimposed DC Transient (Low Power-Factor Effect) Fig. 6.20 shows that the power factor is about 0.3 at starting, causing a significant DC component, so that the total transient inrush current may reach about twice the value of the AC component, even though the latter is of constant amplitude. Peak inrush current (I_t) of 1.4 x normal starting current (I_0) must be allowed for, in selecting the MCCB instantaneous-trip setting.

2. Residual Voltage (Running Restart)

If residual (regenerative) voltages appearing at the motor terminals are out of phase with the supply voltage (at the time of reclosing after being interrupted, before the motor speed is substantially reduced), the cumulative effect of the line voltage and the residual voltage is equivalent to the motor being directly subjected to a large line overvoltage, with a resulting abnormal inrush current of:

$$\frac{\text{Residual+source V}}{\text{Source V}} \times \text{Normal starting inrush current}$$

This is a current magnification effect, which may be as much as 2 x in direct restarting, and $(1 + \frac{1}{\sqrt{3}})$ x in Y-delta-switching restarting. When the DC-transient factor (§1 above) is added, the magnification becomes 2.4 in the case of direct restarting, and 1.9 for Y-delta restarting.

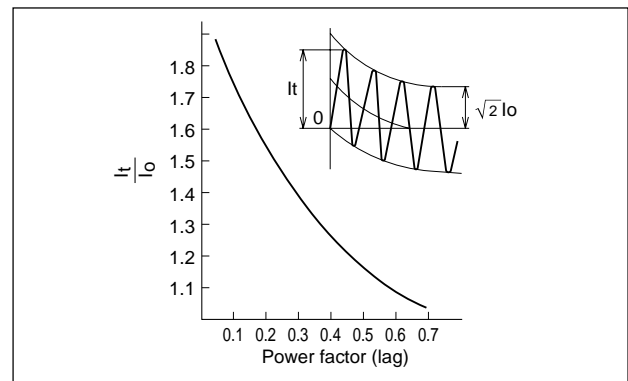

Fig. 6.20 Transient DC Component

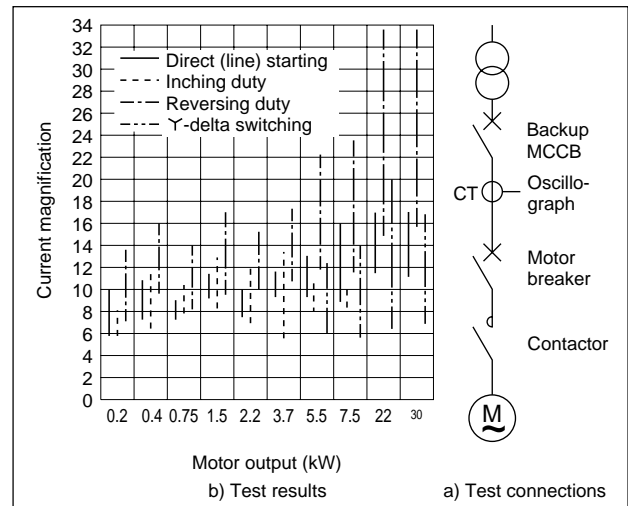

Fig. 6.21 Peak Inrush-Current Measurements

Thus, if normal starting current is assumed as 600% of full-load current, the peak inrush becomes 1200% in Y-delta restarting and 1600% in direct restarting. The MCCB instantaneous-trip setting must be selected at larger than these values.

Fig. 6.21 shows test data with respect to four conditions of transient inrush current, expressed as magnifications of full-load current, measured on motors rated from 0.2~30kW. The MCCB was used for line-starting switching, and the contactor for the other switching duties. Phase matching between the line and residual voltages was uncontrolled.

The oscillographs taken showed that the peak inrush currents persist for about one-half cycle, followed by a rapid decrease to normal starting-current level. From the curves it can be concluded that peak inrush magnifications vary greatly depending on the duty involved; for reversing duty, the MCCB instantaneous trip settings must be selected from 1600 ~ 3400% of full-load current. For line starting and Y-delta starting, the range spans from 1000~2000%.

6.8 Coordination with Devices on the High-Voltage Circuit.

6.8.1 High-Voltage Power Fuse

The MCCB on the secondary (low-voltage) side of a power transformer must have tripping characteristics that provide protective coordination with the power fuse (PF) on the high-voltage side (Fig. 6.22). The MCCB must always trip in response to overcurrent, to ensure that the PF does not fuse or deteriorate by elevated temperature aging.

Fig. 6.23 shows the MCCB curve in relationship to the deteriorated PF curve (if this is unavailable, the average fusing curve reduced by 20% can usually be assumed). The PF characteristic can be converted to the secondary side, or the MCCB characteristic to the primary side; the curves must not overlap in the overcurrent region.

Where the MCCB instantaneous-tripping current of the MCCB is adjustable, difficulties in matching the curves can be overcome as shown, but a 10% margin must be included to allow for the tolerance of the MCCB tripping setting.

The shaded area in Fig. 6.23 belongs to overcurrent region, the overcurrent generally occurs at the lower circuit of MCCB₂.

Thus, it may in some cases be better to accept a coordination between the PF and MCCB₂, permitting a mismatch between the PF and MCCB₁.

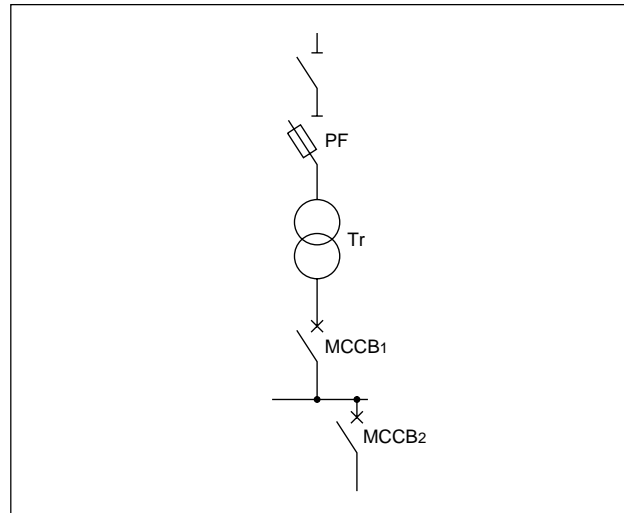

Fig. 6.22 Protective Coordination of MCCBs and HV-Side PF

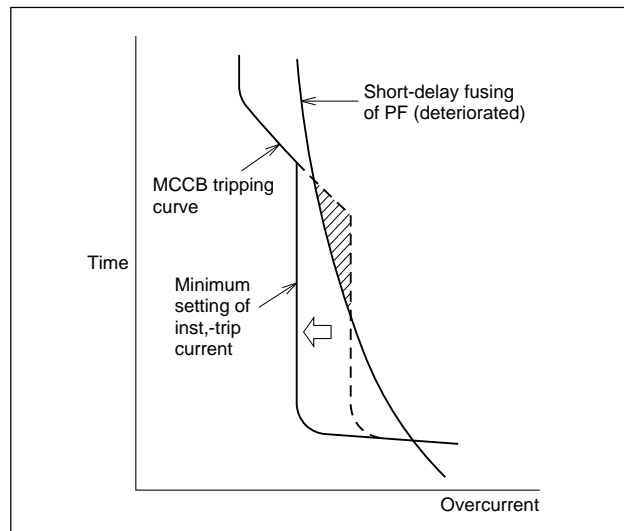

Fig. 6.23 Coordinated PF and MCCB Characteristics

6.8.2 Electronic MCCBs and HV PF

A basic requirement is that the deteriorated short-delay curve of the PF, and the short-delay trip curve of Electronic MCCB, which is shifted +10% along the current axis, do not overlap.

To facilitate matching, the rated current of the PF should be as large as possible; however, there is an upper limit, as seen from the following criteria:

1. The rated current should be 1.5~2 times the load current.
2. To ensure protection in the event of a short circuit, the PF must interrupt a current of 25 times the transformer rating within 2 seconds.
3. To ensure that the PF neither deteriorates nor fuses as a result of the transformer excitation surge current, the short-delay deterioration curve of the PF must be more than 0.1 seconds, at a current of 10 times the transformer rating. The "10 times" factor becomes "15 times" in the case of a single-phase transformer.

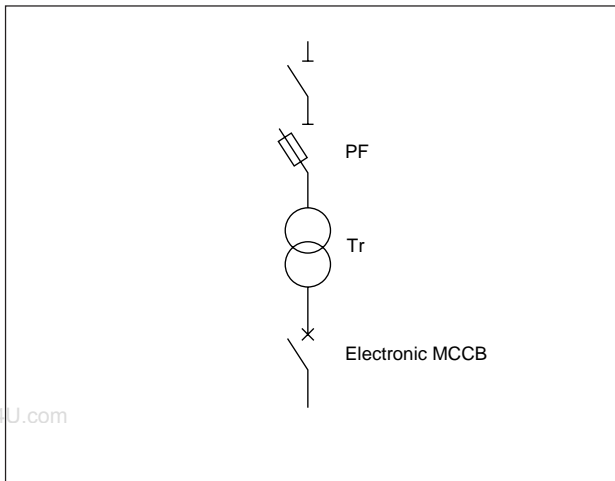

Fig. 6.24 Protective Coordination of Electronic MCCBs and PF

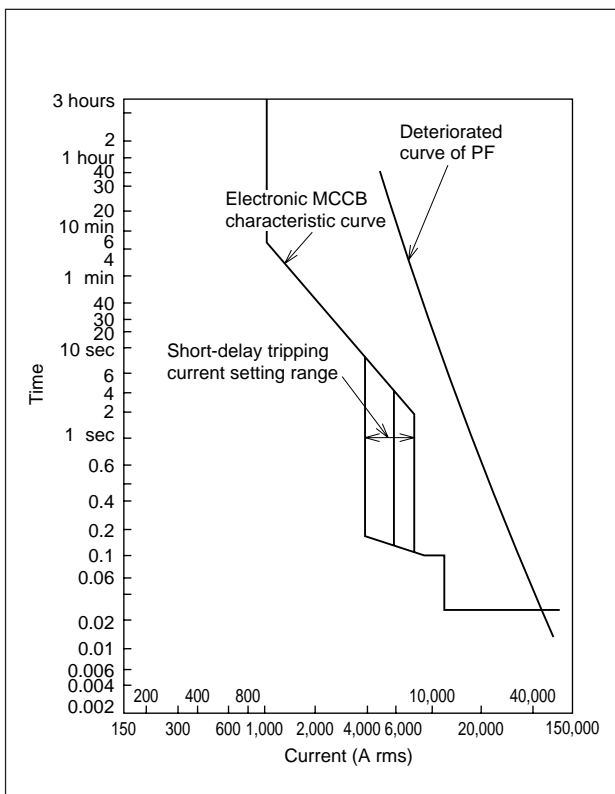

Fig. 6.25 Coordinated PF and Electronic MCCB Characteristics

6.8.3 MCCBs and HV-Side OCR

An overcurrent-relay remote tripping device (OCR) on the HV side of the circuit must be coordinated with the MCCBs on the LV side. The OCR setting must take into consideration the coordination with the OCR at the power-utility substation and, at the same time, the following:

1. The setting of an OCR with an instantaneous-trip element must be at least 10 times the transformer current rating, to ensure that the excitation surge of the latter does not trip the OCR.
2. To ensure short-circuit protection, the OCR must operate within 2 seconds, at 25 times the transformer rated current.

Figs. 6.26 and 6.27 show the setup, and the coordinated characteristics converted to the low-voltage side. The turns ratio of the CT is 150:5, to match the rated primary current of 87.5A. Considering cooperation of the OCR with the upper-ranking substation OCR, the OCR dial is normally set to 0.2 or less, or 1 second max. if it has an instantaneous trip element. On the Mitsubishi Type MOC-E general-purpose relay this is equivalent to dial setting No. 2. Latching-curve overlap, shown by the broken lines in Fig. 6.27, must be allowed for. The instantaneous trip is set to 30A, in accordance with §1, above.

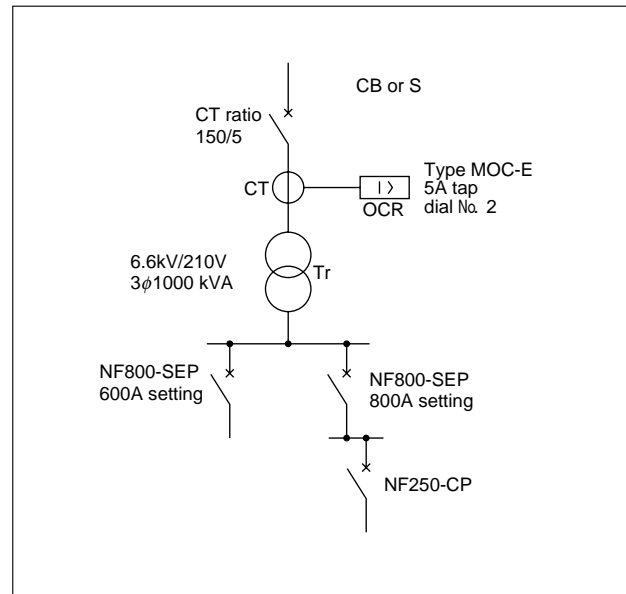

Fig. 6.26 Electronic MCCBs in Coordination with an HV-Side OCR

For setting the Electronic MCCBs (800 and 600A versions of Type NF800-SEP), the short-delay tripping currents of both are set to MIN. NF800-SEP have negligible latching inertia, so that the reset characteristics (except in the instantaneous-trip region) can be regarded as the same as the tripping characteristics. Further, there is very little tolerance variation between units; thus, the tripping characteristics can be shown as a single line.

If the NF800-SEP short-delay trip current is set at MAX (where MIN and MAX respectively correspond to 2 and 10 times rated current), a 600A rating setting will correspond to 6000A tripping, and an 800A setting will correspond to 8000A tripping. In this case (at MAX setting), short-delay latching of the NF800-SEP will overlap the OCR latching (4710A, secondary conversion). But if the NF800-SEP and the OCR are all set to MIN, so that the latching values do not exceed 4710A, good coordination will be achieved.

As the OCR has an instantaneous-trip element, set at 30A (secondary conversion 28.3kA), the region of selective interruption between the OCR and the NF800-SEP will extend to this value.

Considering the coordination of the Electronic MCCBs with the lower-level MCCBs (NF250-CP), it

can be seen from Fig. 6.27 that the maximum trip curve (tolerance) of the C Line units matches well with the NF800-SEP curves, with no danger of overlap.

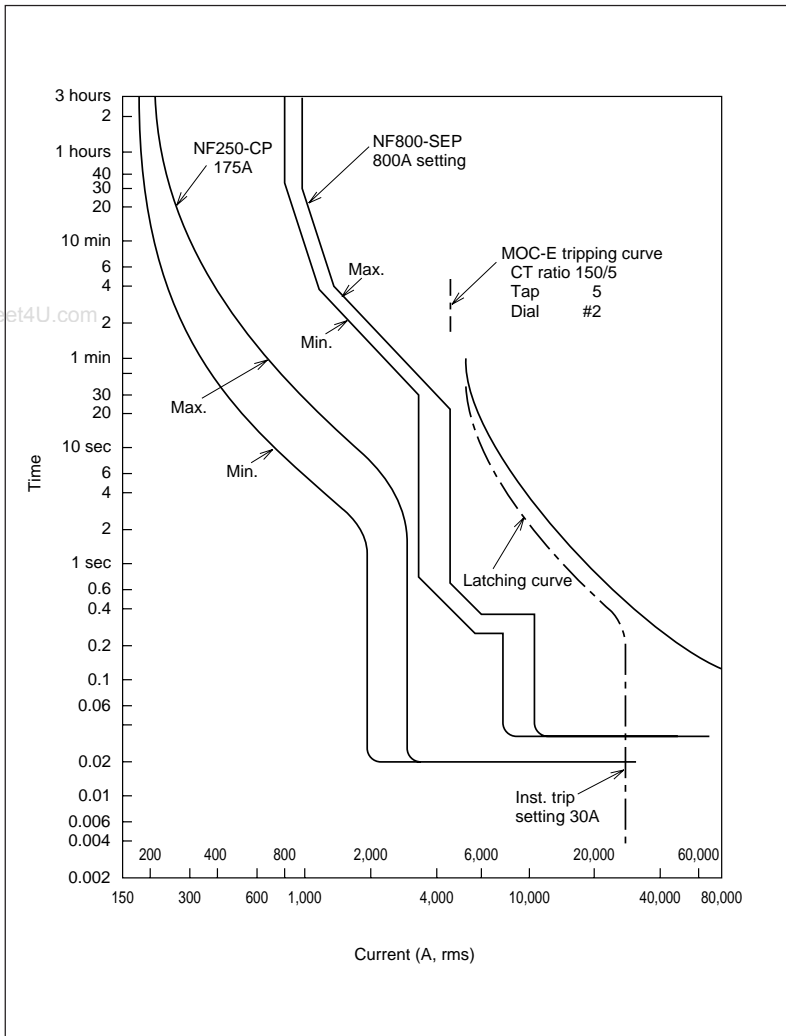

Fig. 6.27 Coordinated OCR and Electronic MCCB Characteristics

7. SELECTION

In selecting MCCBs for a particular application, in addition to purely electrical aspects of load and distribution conductor systems, physical factors such as panelboard configuration, installation environment, ambient-temperature variations, vibration, etc. must also be considered.

MCCBs are rated for an ambient of 40°C, and where panelboard internal temperatures may exceed this, the MCCBs installed should be derated in accordance with Table 7.1.

1. Actual load currents may exceed the nominal-values.
2. Load currents may increase with time, due to deterioration of load devices (i.e., friction in motors).
3. Source voltage and frequency may vary.

Table 7.1 MCCB Deratings Due to Installation Factors

Panelboard max. internal temp. (°C)	Load allowable, due to panelboard temp. (%)
50	90
55	80
60	70

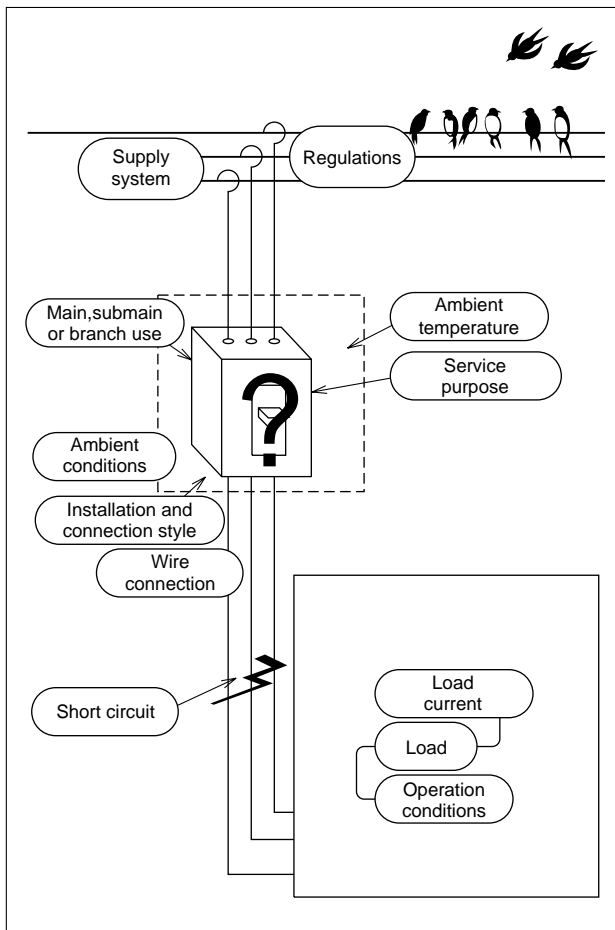

Fig. 7.1 MCCB Selection Consideration

7.1 Motor Branch Circuits

The following discussion assumes single motors and cold-start operation.

7.1.1 General Considerations

The starting current (I_{MS}) and time (T_{MS}) for the motor, and its full-load current, dictate the rated current, long-delay trip and instantaneous-trip curves for the MCCB as shown in Fig. 7.2. A safety-margin of up to 50% should be considered for the starting time, to allow for voltage variations and increase in load friction.

The instantaneous-trip curve should be at least 1.4 x normal starting current to allow for the effect of the DC component attendant to the low power factor (about 0.3) of the starting current. For Υ -delta starting the unphased-switching allowance increases the 1.4 margin to 1.9. For running restarting the unphased-switching allowance increases the factor to 2.4.

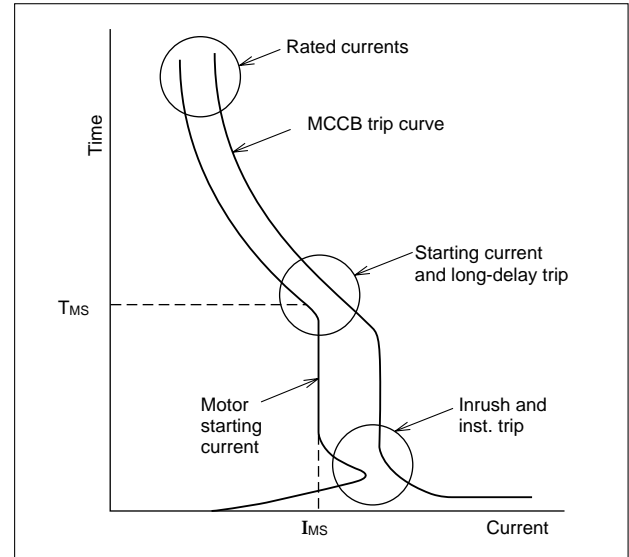

Fig. 7.2 MCCB and Motor Starting

7.1.2 Motor Breaker

Where starting times are relatively short and currents are small, the Mitsubishi M Line motor breakers can be used without the need for a motor starter.

7.2 For Lighting and Heating Branch Circuits

In such circuits, switching-surge magnitudes and times are normally not sufficient to cause spurious tripping problems; however, in some cases, such as mercury-arc lamps or other large starting-current equipment, the methods presented in §7.1 above should be considered.

In general, branch MCCBs should be selected so that the total of ratings of the connected loads is not more than 80% of the MCCB rating.

7.3 For Main Circuits

7.3.1 For Motor Loads

The method of “synthesized motors” is recommended – that is, the branch-circuit loads to be connected are divided into groups of motors to be started simultaneously (assumed), and then each group is regarded as a single motor having a full-load current of the total of the individual motors in the group. The groups are regarded as being sequentially started.

The rating of the branch MCCB for the largest synthesized motor is designated $I_B \text{ max.}$, those of the subsequent synthesized motors as I_1, I_2, \dots, I_{n-1} . The rating of the main MCCB becomes:

$$I_{\text{MAIN}} = I_B \text{ max.} + (I_1 + I_2 + \dots + I_{n-1}) \times D$$

where D is the demand factor (assumed as 1 if indeterminate).

7.3.2 For Lighting and Heating, and Mixed Loads

For lighting and heating loads the rating of the main MCCB is given as the total of the branch MCCB ratings times the demand factor. For cases where both motor-load branches and lighting and heating branches are served by a common main MCCB, the summation procedures are handled separately, as described in the foregoing, then grand-totalized to give the main MCCB rating.

7.4 For Welding Circuits

7.4.1 Spot Welders

A spot welder is characterized by a short, heavy intermittent load, switched on the transformer primary side. The following points must be considered in MCCB selection:

1. The intermittent load must be calculated in terms of an equivalent continuous current.
2. The excitation transient surge due to the breaker being on the transformer primary side must be allowed for.

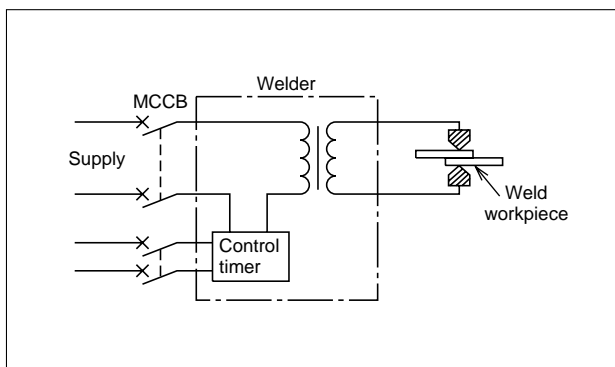

Fig. 7.3 Spot-Welder Circuit

The temperature rise of the MCCB and wiring depends on the thermal-equivalent continuous current. To convert the welder intermittent current into a thermal-equivalent continuous value (I_e), consider the current waveform (Fig. 7.4); load resistance (R) gives power dissipation:

$$W = I_1^2 R t_1$$

and average heat produced:

$$\frac{W}{t_1 + t_2} = \frac{I_1^2 R t_1}{t_1 + t_2} = I_1^2 R \beta = R(I_1 \sqrt{\beta})^2$$

where β is the duty factor, defined as

$$\frac{\text{total conduction time}}{\text{total time}}$$

This is equivalent to heating by a continuous current of $I_1 \sqrt{\beta}$.

In the example of Fig. 7.4:

$$I_e = I_1 \sqrt{\beta} = 1200 \times 0.0625 = 300 \text{ (A)}$$

i.e., a continuous current of 300A will produce the average temperature. In practice, however, the instantaneous temperature will fluctuate as shown in Fig. 7.5 and the maximum value (T_m) will be greater than the average (T_e) that would be produced by a continuous current of 300A. The operation of an MCCB thermal element depends on the maximum rather than the average temperature, so it must be selected not to trip at T_m ; in other words, it is necessary to ensure that its hot-start trip delay is at least as great as the interval of current flow in the circuit. The rated current of a “mag-only” MCCB (which does not incorporate a thermal trip function) can be selected based on the thermal equivalent current of the load, allowing a margin of approximately 15% to the calculated value to accommodate supply-voltage fluctuations, equipment tolerance, etc. Thus:

$$I_{\text{MCCB}} = I_e \times 1.15 = 300 \times 1.15 = 345 \text{ (A)}$$

The MCCB selected becomes the nearest standard value above 345A.

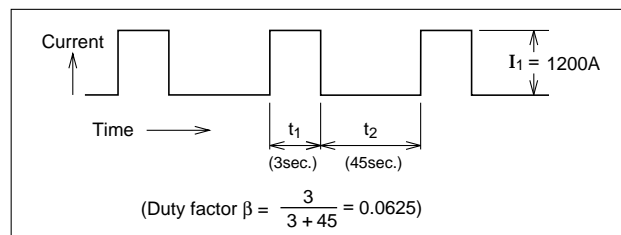

Fig. 7.4 Welder Intermittent Current

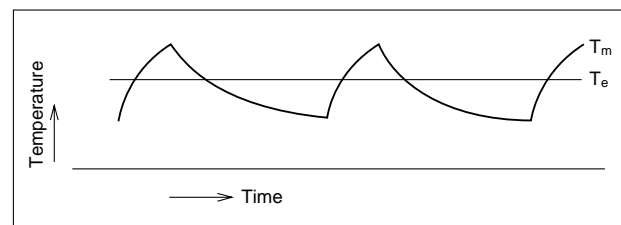

Fig. 7.5 Temperature Due to Intermittent Current

For practical considerations, rather than basing selection on welding conditions, the MCCB should be selected to accommodate the maximum possible duty, based on the capacity and specifications of the welder.

If the welder rated capacity, voltage and duty factor in Fig. 7.3 are 85kVA, 200V and 50% respectively, the thermal-equivalent continuous current (I_e) be-

comes:

$$I_e = \frac{\text{rated capacity}}{\text{rated voltage}} \times \sqrt{\text{duty factor}}$$

$$= \frac{85 + 10^3}{200} \times \sqrt{0.5} = 300\text{A}$$

Hence, the MCCB rated current becomes:

$$I_{MCCB} = I_e \times 1.15 = 300 \times 1.15 = 345\text{A}$$

(i.e., the next higher standard value).

The relationship between the duty factor, which does not exceed the working limitations, and the maximum permissible input I_β at the above duty factor is:

$$I_\beta = \frac{I_e}{\sqrt{\beta}} = \frac{300}{\sqrt{\beta}}$$

If the total period is taken as 60 seconds and the duty factor is converted into the actual period during which current flows, the above relationship can be expressed graphically as in Fig. 7.6. Thus, although the thermal equivalent current is 300A, the maximum permissible input current for a duty factor of 50% (30 seconds current flow) is 425A. For a duty factor of 6.25% (3.75 sec current flow) it is 1200A. Even if the secondary circuit of the welder were short circuited, however, the resultant primary current would only increase by about 30% over the standard maximum welding current. If this is 400kVA, the maximum primary current $I_{\beta\max}$ is:

$$I_{\beta\max} = \frac{\text{standard maximum input}}{\text{primary voltage}} \times 1.3$$

$$= \frac{400 \times 10^3}{200} \times 1.3 = 2600\text{A}$$

Hence the maximum input current I_β should be restricted to 2600A.

The 75% hot-start characteristic of the 350A Type NF400-SP breaker is shown by the broken line in Fig. 7.6, and the temperature-rise characteristics up to the upper limit of the welder, by the solid line. To ensure protection of the welder from burnout, the delay-trip characteristic is selected at higher than the solid line; however, to establish MCCB protection criteria, it is necessary to look at each welder individually.

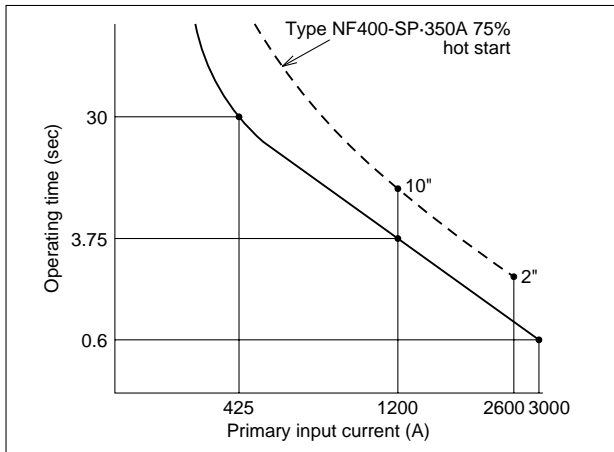

Fig. 7.6 Welder Temperature Rise and MCCB Trip Curve

7.4.2 MCCB Instantaneous Trip and Transformer Excitation Surge

When a welding-transformer primary circuit is closed, depending upon the phase angle at the instant of closure, a transient surge current will flow, due to the super-imposed DC component and the saturation of the transformer core.

In order to prevent spurious tripping of protective devices resulting from such surges, and also to maintain constant welding conditions, almost all welders currently available are provided with a synchronized switch-on function, with or without wave-peak control.

With synchronized switch-on, the measured ratio between the RMS value of the primary current under normal conditions and the maximum peak transient current ranges from $\sqrt{2} \sim 2$.

For nonsynchronized soft-starting-type welders the measured ratio is a maximum of 4.

Maximum instantaneous transient surge excitation currents for various starting methods are as follows: Synchronized switch-on welders with wave peak control:

$$I_{\max} = \sqrt{2} \times I_{\beta\max}$$

Synchronized switch-on welders without wave peak control:

$$I_{\max} = 2 \times I_{\beta\max}$$

Nonsynchronized switch-on welders with soft start:

$$I_{\max} = 4 \times I_{\beta\max}$$

Nonsynchronized switch-on welders without soft start:

$$I_{\max} = 20 \times I_{\beta\max}$$

If synchronized switch-on is employed, the transient surge excitation currents are relatively consistent, so that the relationship $I_{\max} = 2 I_{\beta\max}$ is sufficient.

For a synchronized switch-on type welder of maximum primary input ($I_{\beta\max}$) = 2600A

$$I_{\max} = 2 \times I_{\beta\max} = 2 \times 2600 = 5200\text{A}$$

Since MCCB instantaneous trip currents are specified in terms of RMS value, I_{inst} is as follows:

$$I_{\text{inst}} = \frac{I_{\max}}{\sqrt{2}} = \frac{5200}{\sqrt{2}} = 3680\text{A}$$

The MCCB should be selected so that I_{inst} is smaller than the lower tolerance limit, of the instantaneous trip current.

7.4.3 Arc Welders

An arc welder is an intermittent load specified. The MCCB rating can be selected by converting the load current into thermal-equivalent continuous current. If this is taken as the rated current, however, the current duration per cycle will become relatively long, with the attendant danger of thermal tripping of the MCCB. In the total period of 10 minutes, if the duty factor is 50%, a 141% overload exists for 5 minutes; if the duty factor is 40%, a 158% overload exists for 4 minutes; and if the duty factor is 20%, a 224% overload exists

for 2 minutes. Thus:

$$I_{MCCB} \geq \frac{1.2 \times P \times 10^3}{E}$$

where 1.2: Allowance for random variations in arc-welder current, and supply-voltage fluctuations

P: Welder rated capacity (kVA)

E: Supply voltage (V)

The switching transient in the arc welder is measured as 8~9 times the primary current. Consequently, using 1.2 allowance, it is necessary to select instantaneous-trip characteristics such that the MCCB does not trip with a current of 11 times the primary current.

7.5 MCCBs for Transformer-Primary Use

Transformer excitation surge current may possibly exceed 10 times rated current, with a danger of nuisance tripping of the MCCB. The excitation surge current will vary depending upon the supply phase angle at the time of switching, and also on the level of core residual magnetism. The maximum is as shown for switching-point P in Fig. 7.7. During the half cycle following switch-on the core flux will reach the sum of the residual flux ϕ_r , plus the switching-surge flux $2\phi_m$.

The total, $2\phi_m + \phi_r$, represents an excitation current in excess of the saturation value. The decay-time constant of this tends to be larger for larger transformer capacities. Table 7.2 shows typical values of excitation surge current, but as these do not take circuit impedance into account, the actual values will be larger. If both the primary leakage impedance and circuit impedance are known, the surge current may be derived by considering the transformer as an air core reactor; otherwise the values in Table 7.2 should be used. This table gives maximum values, however, that are based on the application of rated voltages to rated taps; it should be noted that supply overvoltage will result in even larger surges.

Since it is the instantaneous-trip function of the MCCB that responds to the transient current, thermal-magnetic MCCBs, which can more easily be manufactured to handle high instantaneous-trip currents, are advantageous over completely electromagnetic types, where the instantaneous-trip current is a relatively small multiple of the rated current.

Table 7.2 Transformer Excitation Surge Currents

Capacity (kVA)	1ph transformer		3ph transformer	
	First 1/2-cycle peak	Decay time constant	First 1/2-cycle peak	Decay time constant
	(multiple) ¹	(Hz)	(multiple) ¹	(Hz)
5	37	4	26	4
10	37	4	26	4
15	35	5	26	4
20	35	5	26	4
30	34	6	26	4
50	34	6	23	5
75	29	6	18	5
100	28	6	17	5
150	24	8	14	6
200	22	8	13	6
300	18	9	13	8
500	17	12	11	9

Note: 1 "Multiple" means the first 1/2-cycle peak as a multiple of the rated-current peak.

Table 7.3 Transformer Capacities and Primary-Side MCCBs

Tran. kVA	MCCB Type (rated current (A))			
	1 phase 230V	1 phase 400V	3 phase 230V	3 phase 400V
5	NF100-SP (75)	NF100-SP (40)	NF50-SP (50)	NF30-SP (30)
7.5	NF100-SP (100)	NF100-SP (60)	NF100-SP (40)	NF50-SP (40)
10	NF250-SP (150)	NF100-SP (75)	NF100-SP (60)	NF50-SP (50)
15	NF250-SP (200)	NF250-SP (125)	NF100-SP (100)	NF100-SP (50)
20	NF400-SP (300)	NF250-SP (150)	NF250-SP (125)	NF100-SP (60)
30	NF400-SP (400)	NF250-SP (225)	NF250-SP (175)	NF100-SP (100)
50	NF630-SEP (600)	NF400-SP (400)	NF400-SP (250)	NF250-SP (150)
75	NF1000-SS (500)	NF630-SP (500)	NF400-SP (300)	NF250-SP (175)
100	NF1000-SS (500)	NF630-SP (630)	NF400-SP (400)	NF250-SP (225)
150	NF1000-SS (800)	NF1000-SS (500)	NF630-SP (500)	NF400-SP (300)
200	NFE2000-S (1200)	NF1000-SS (600)	NF630-SP (600)	NF400-SP (350)
300	NFE2000-S (1500)	NF1000-SS (900)	NF1000-SS (900)	NF630-SP (600)
500	—	NFE2000-S (1400)	NF1600-SS (1400)	NF1000-SS (900)

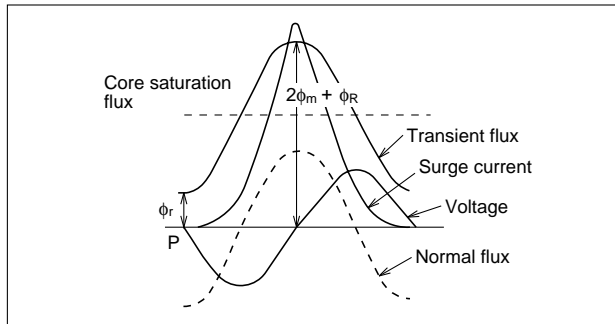

Fig. 7.7 Excitation Surge Effects

In MC CB selection for 400V, 50kVA transformer-primary used, rated RMS current is:

$$I = \frac{\text{Capacity (kVA)} \times 10^3}{\sqrt{3} \times \text{Voltage (V)}} = \frac{50 \times 10^3}{\sqrt{3} \times 400} = 72.2\text{A}$$

From Table 7.2, the peak value of the excitation surge current $I\phi$ is 23 times that of the rated current, hence:

$$I\phi = 23 \times \sqrt{2} \times I = 23 \times \sqrt{2} \times 72.2\text{A} = 2348\text{A}$$

Thus the MCCB selected should have instantaneous trip current of no less than 2348A. The Type NF250-SP 150A MCCB, with:

$$I_{\text{inst}} = \sqrt{2} \times 150 \times 11.2 = 2376\text{A}$$

satisfies the above condition. Thus the 3-pole version of this type is suitable for this application.

Examples of MCCBs selected in this way are shown in Table 7.3; it is necessary to confirm that the short-circuit capacities of the breakers given are adequate for the possible primary-side short-circuit current in each case.

7.6 MCCBs for Use in Capacitor (PF Correction) Circuits

The major surge tendency results from circuit opening due to the leading current. If the capacitor circuit of Fig. 7.8 is opened at time t_1 in Fig. 7.8, arc extinction will occur at time t_2 , the zero-point of the leading current (i). Subsequently the supply-side voltage (V_t) will vary normally, but the load-side voltage (V_c) will be maintained at the capacitor charge value. The potential difference ($V_c - V_t$) will appear across the MCCB contacts and at time t_3 , approximately 1/2-cycle after t_2 , will become about twice the peak value of the supply voltage (E_m). If the MCCB contacts are not sufficiently open, an arc will reappear across the gap, resulting in an oscillatory capacitor discharge (at a frequency determined by the circuit reactance, including the capacitor) to an initial peak-to-peak amplitude of $4E_m$. When the arc extinguishes, V_c will once again be maintained at a potential of $-E_m$ and the potential difference across the MCCB contacts will increase again. This cycle will repeat until the gap between the contacts becomes too great, and the interruption will be completed.

Since Mitsubishi MCCBs exhibit extremely rapid contact separation, repetitive arcing is virtually non-

existent; however, some MCCBs do not make and break so rapidly, and in such cases, if the load capacitance is large enough, they will not discharge quickly, and if the arc extinguishes near the peak of the reverse-going oscillation voltage, the capacitor voltage will be maintained in the region of $-3E_m$ by the first restriking of the arc; at the second restriking it will become $5E_m$, on the third $-7E_m$, etc., ultimately leading to breakdown of the capacitor. Thus, rapid switching is essential in leading power-factor circuits.

In selecting an MCCB, first consider the surge current. If the supply voltage is V volts, the capacitor C farads, the frequency f Hertz and the current I amp, the kVA rating (P) becomes:

For a three-phase system:

$$1000 P = \sqrt{3} VI = 2\pi f CV^2$$

For a single-phase system:

$$1000 P = VI = 2\pi f CV^2$$

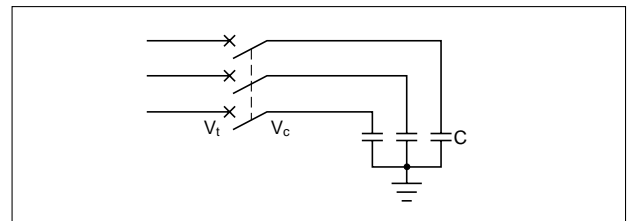

Fig. 7.8 Capacitor Circuit

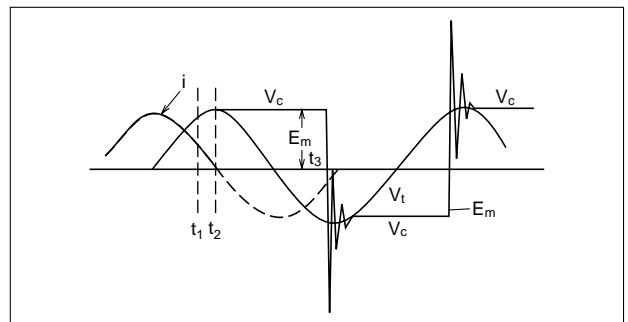

Fig. 7.9 Circuit-Opening Conditions

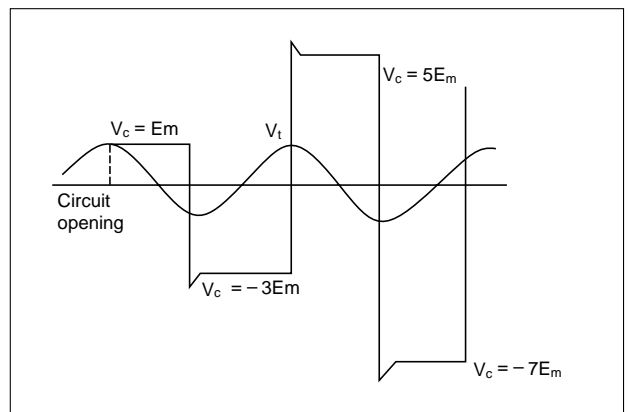

Fig. 7.10 Accumulative Capacitor Charge

When the switch (Fig. 7.11) is closed, a charge ($q=CV$) must be instantaneously supplied to equal the

instantaneous supply voltage (V), according to the phase angle at the instant of circuit closure. This charge results in a large surge current. If the circuit is closed at the peak (E_m) of the supply voltage (V), the surge current (i), according to transient phenomena theory, is:

$$i = \frac{2 E_m}{\sqrt{\frac{4L}{C} - R^2}} \varepsilon^{-\frac{R}{2L} t} \sin \sqrt{\frac{4L}{C} - R^2} t$$

From Fig. 7.12, the maximum value (i_m) is:

$$i_m = \frac{E_m}{\sqrt{\frac{L}{C}}} \varepsilon^{-\frac{R}{\sqrt{\frac{4L}{C} - R^2}} \arctan \frac{\sqrt{\frac{4L}{C} - R^2}}{R}}$$

and appears at time $t = \tau_0$ where:

$$\tau_0 = \frac{2L}{\sqrt{\frac{4L}{C} - R^2}} \arctan \frac{\sqrt{\frac{4L}{C} - R^2}}{R}$$

Although V is not constant, τ_0 is extremely small, so that $V = E_m$ can be assumed for the transient duration; similarly, the conduction time can be assumed as $2\tau_0$. Thus, an MCCB for use in a capacitive circuit must have an instantaneous-trip current of greater than $i_m \times 2\tau_0$.

Example: MCCB selection for a 3-phase 230V 50Hz 150 kVA capacitor circuit.

From Table 7.4, $C = 0.9026 \times 10^{-2}$ (F) and $I = 377$ (A).

The values of R and L in the circuit must be estimated, and for this purpose it is assumed that the short-circuit current is approximately 100 times the circuit capacity – i.e., 50,000A.

$$Z = \sqrt{R^2 + (2\pi fL)^2} \therefore 50,000 = \frac{V}{\sqrt{3} Z}$$

$$\text{thus: } Z = \frac{230}{\sqrt{3} \times 50,000} = 2.66 \times 10^{-3}$$

$$\text{and assuming: } \frac{2\pi fL}{R} = 5$$

$$\text{then: } 2\pi fL = 2.60 \times 10^{-3} \Omega$$

$$\text{thus: } R = 5.21 \times 10^{-4} \Omega \quad L = 8.29 \times 10^{-6} \text{ (H)}$$

$$\text{since: } E_m = \frac{\sqrt{2}}{\sqrt{3}} V = 188, i_m \text{ and } \tau_0 \text{ can be}$$

obtained from their respective formulas as,

$$i_m = 6200A$$

$$\tau_0 = 4.27 \times 10^{-4} \text{ (sec).}$$

Since current-flow duration is approximately $2\tau_0$, an MCCB is selected with a latching time of 0.001 seconds at 6200A. The Type NF630-SP is suitable, having a latching time of 0.0029 seconds at 10,000A. Even with a shorter latching time, tripping is unlikely

under the application of the above current, but selection of an MCCB with an instantaneous-trip current of greater than $\frac{6200}{\sqrt{2}} = 4400A$ is recommended for an adequate safety margin. Such an MCCB will be rated at 600A. Accordingly, in this example the Type NF630-SP, rated at 600A, is selected. Table 7.4 is a basis for selection, but since, in cases where the short-circuit capacity of the circuit is considerably higher than that of the MCCB, spurious tripping due to the switching surge may occur, it is also necessary to make calculations along the lines of the above example.

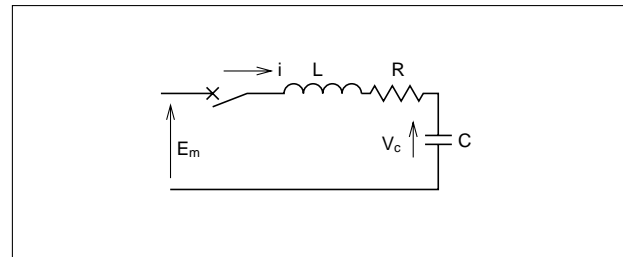

Fig. 7.11 PF Correction Capacitor

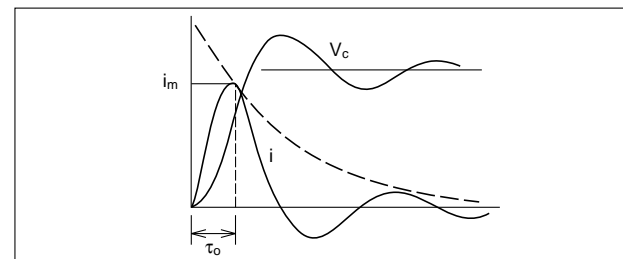

Fig. 7.12 Currents and Voltages

7.7 MCCBs for Thyristor Circuits

Both overcurrent and overvoltage protection must be provided for these elements. MCCBs can be used effectively for overcurrent, although application demands vary widely, and selection must be made carefully in each case. Overvoltage protection must be provided separately; devices currently in use include lightning arresters, dischargers, RC filters and others.

1. MCCB Rated Currents

A primary factor determining the rated current of the MCCB to be used is the question of AC-side or DC-side installation. AC-side installation permits a lower rating, which is a considerable advantage. Fig. 7.13 shows both AC and DC installation (MCCBs 1 and 2); Table 7.5 gives a selection of circuit formats and current configurations; using this table it is possible to determine the MCCB rating for either MCCB 1 or 2, as required. The current curve of the thyristor (average current is usually given) and the tripping curve of the MCCB should be rechecked to ensure that there is no possibility of overlap.

When an overcurrent is due to a fault in the load, causing a danger of thermal destruction of the circuit elements, either AC or DC protection is adequate, provided the parameters are properly chosen. When

Table 7.4 MCCB Selection for Circuits with PF-Correction

a) 230V, 50Hz Circuit

Capacitor rating		Single-phase circuit		Three-phase circuit	
kVA	μF	Capacitor rated current (A)	MCCB rated current (A)	Capacitor rated current (A)	MCCB rated current (A)
5	301	21.7	40	12.6	20
10	602	43.5	75	25.1	40
15	903	65.2	100	37.7	60
20	1203	87.0	125	50.2	75
25	1504	108.7	175	62.8	100
30	1805	130.4	200	75.3	125
40	2407	173.9	250	100.4	150
50	3009	217.4	350	125.5	200
75	4513	326.1	500	188.3	300
100	6017	434.8	700	251.0	400
150	9026	652.2	1000	376.5	600
200	12034	869.6	1400	502.0	800
300	18052	1304.3	2000	753.1	1200
400	24069	1739.1	2500	1004.1	1500

c) 400V, 50Hz Circuit

Capacitor rating		Single-phase circuit		Three-phase circuit	
kVA	μF	Capacitor rated current (A)	MCCB rated current (A)	Capacitor rated current (A)	MCCB rated current (A)
5	99	12.5	20	7.2	15
10	199	25.0	40	14.4	30
15	298	37.5	60	21.7	40
20	398	50.0	75	28.9	50
25	497	62.5	100	36.1	60
30	597	75.0	125	43.3	75
40	796	100.0	150	57.7	100
50	995	125.0	200	72.2	125
75	1492	187.5	300	108.3	175
100	1989	250.0	400	144.3	225
150	2984	375.0	600	216.5	350
200	3979	500.0	800	288.7	500
300	5968	750.0	1200	433.0	700
400	7958	1000.0	1500	577.4	900

b) 230V, 60Hz Circuit

Capacitor rating		Single-phase circuit		Three-phase circuit	
kVA	μF	Capacitor rated current (A)	MCCB rated current (A)	Capacitor rated current (A)	MCCB rated current (A)
5	251	21.7	40	12.6	20
10	501	43.5	75	25.1	40
15	752	65.2	100	37.7	60
20	1003	87.0	125	50.2	75
25	1254	108.7	175	62.8	100
30	1504	130.4	200	75.3	125
40	2006	173.9	250	100.4	150
50	2507	217.4	350	125.5	200
75	3761	326.1	500	188.3	300
100	5014	434.8	700	251.0	400
150	7522	652.2	1000	376.5	600
200	10029	869.6	1400	502.0	800
300	15043	1304.3	2000	753.1	1200
400	20057	1739.1	2500	1004.1	1500

d) 400V, 60Hz Circuit

Capacitor rating		Single-phase circuit		Three-phase circuit	
kVA	μF	Capacitor rated current (A)	MCCB rated current (A)	Capacitor rated current (A)	MCCB rated current (A)
5	83	12.5	20	7.2	15
10	166	25.0	40	14.4	30
15	249	37.5	60	21.7	40
20	332	50.0	75	28.9	50
25	414	62.5	100	36.1	60
30	497	75.0	125	43.3	75
40	663	100.0	150	57.7	100
50	829	125.0	200	72.2	125
75	1243	187.5	300	108.3	175
100	1658	250.0	400	144.3	225
150	2487	375.0	600	216.5	350
200	3316	500.0	800	288.7	500
300	4974	750.0	1200	433.0	700
400	6631	1000.0	1500	577.4	900

- Notes: 1. The MCCB rated current should be approx. 150% of the capacitor rated current.
 2. The MCCB short-circuit capacity should be adequate for the circuit short-circuit capacity.

the fault is in one of the thyristor elements, resulting in reverse current, the result is often that other circuit elements will be destroyed (see Fig. 7.14) if the circuit is not interrupted immediately. In this case AC-side protection or protection in series with each element is necessary.

2. Thyristor Overcurrent Protection

Total protection of each element is possible in theory, but in practice overall coordination and the best compromise for economy are usually demanded. Where elements are critical, complex combinations of protective devices can be employed, at proportionally higher cost.

Basically, overcurrent leads to excessive temperature rise of the thyristor junction, resulting in loss of the control function, and thermal destruction. A fault, therefore, must be interrupted as quickly as possible, before the junction temperature rises above its specified limit. In the overcurrent region, designated on the current-surge withstand curves of the circuit element, the element can usually withstand the surge for at least one cycle. The current-surge withstand, generally specified as a peak value, must be converted to RMS, to select a suitable MCCB.

An overload of short-circuit proportion, either external or in a bridge-circuit thyristor element, necessi-

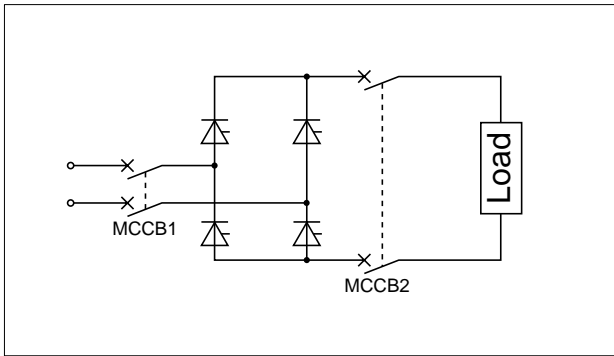

Fig. 7.13 AC- and DC-side Protectors for Thyristors

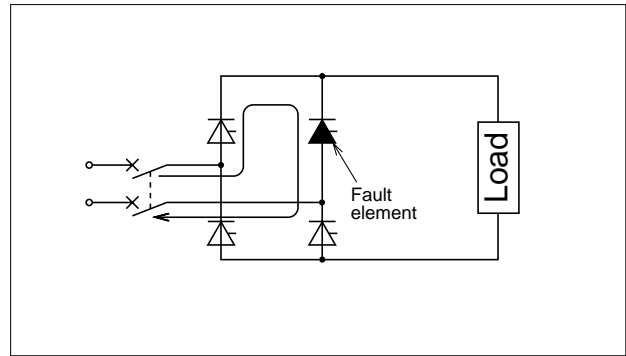

Fig. 7.14 Fault-Current Flow

Table 7.5 Thyristor Circuits and Current Formats

		Circuit No. I	Circuit No. II	Circuit No. III	Circuit No. IV	
Circuit diagram						
Element average current I_F (A)		$\frac{I_P}{\pi}$	$\frac{I_P}{\pi}$	$\frac{I_P}{\pi}$	$\frac{I_P}{\pi}$	
Element RMS current I_e (A)		$\frac{I_P}{2}$	$\frac{I_P}{2}$	$\frac{I_P}{2}$	$\sqrt{\frac{1}{6} + \frac{M3}{4\pi}} I_P$ ($\approx 0.552 I_P$)	
Average DC current I_D (A)		I_F	$2I_F$	$2I_F$	$3I_F$	
Current flow	MCCB1	RMS current I_B (A) $\frac{\pi}{2} I_F$ or $\frac{\pi}{2} I_D$	$\frac{\pi}{2} I_F$ or $\frac{\pi}{4} I_D$	$\frac{\pi}{M2} I_F$ ($\approx 2.22 I_F$) or $\frac{\pi}{2M2} I_D$ ($\approx 1.11 I_D$)	$\pi \sqrt{\frac{1}{3} + \frac{M3}{2\pi}} I_F$ ($\approx 2.45 I_F$) or $\frac{\pi}{3} \sqrt{\frac{1}{3} + \frac{M3}{2\pi}} I_D$ ($\approx 0.817 I_D$)	
		Current waveform				
	MCCB2	RMS current I_B (A) I_e or $\frac{\pi}{2} I_D$	$\frac{\pi}{M2} I_F$ or $\frac{\pi}{2M2} I_D$	$\frac{\pi}{M2} I_F$ or $\frac{\pi}{2M2} I_D$	$\pi \sqrt{\frac{1}{2} + \frac{3M3}{4\pi}} I_F \approx 3I_F$ or $\frac{\pi}{3} \sqrt{\frac{1}{2} + \frac{3M3}{4\pi}} I_D \approx I_D$	
		Current waveform				

Note: Load is assumed resistive, with elements conductive through 180°.

tates rapid interruption of the circuit. Normally, such interruption takes place within one cycle; thus, from the point of view of element thermal destruction, the time integral of the current squared must be considered. Quantitatively, the permissible $\int i^2 dt$ of the element must be greater than the $\int i^2 dt$ of the MCCB current through interruption, converted to apply to the element. The latter is influenced by the short-circuit current magnitude, the interruption time, and the current-limiting capability of the MCCB.

It is important to note that the MCCB interruption time will be considerably influenced by the short-circuit current rise rate, di/dt , on the load side. In the short circuit of Figs. 7.15 and 7.16, the current is:

$$i = \frac{E}{R} (1 - e^{-\frac{R}{L}t})$$

and the current rise rate di/dt is:

$$\left(\frac{di}{dt} \right)_{t=0} = \frac{E}{L}$$

Thus, the inductance of the line, and the smoothing inductance significantly affect di/dt . Where the potential short-circuit current is very large, the inductance should be increased, to inhibit the rise rate and assist the MCCB to interrupt the circuit in safe time. This is illustrated in Fig. 7.17, for MCCB2 of Fig. 7.15.

The MCCB current during total time (t_T) is $\int i^2 dt$, which, converted to the $\int i^2 dt$ applied to the circuit element, must be within the limit specified. Having determined the circuit constants, testing is preferable to calculation for confirmation of this relationship.

Assuming a large current-rise rate, with an AC-side short-circuit current $i = I_{ps} \sin \omega t$, and an MCCB interruption time of one cycle, the $\int i^2 dt$ applied to the thyristor is as follows:

1. For circuits I, II and III of Table 7.10:

$$\int i^2 dt = \int_0^{2f} I_p^2 \sin^2 \omega t dt = \frac{1}{4f} I_p^2 (A^2 \text{sec})$$

2. For circuit IV:

$$\int i^2 dt = 2 \int_0^{3f} I_p^2 \sin^2 \omega t dt = \frac{I_p^2}{f} \left(\frac{1}{6} + \frac{\sqrt{3}}{4\pi} \right) (A^2 \text{sec})$$

where I_p is the peak value of the element current and f is the supply frequency.

If the $\int i^2 dt$ of the circuit element is known, the permissible $\int i^2 dt$ for the MCCB can be determined, using the last two equations given above. Provided that the interruption time is not greater than one cycle, the MCCB current will be the same as the element current for circuits I and II, and twice that for circuits III and IV. This means that the MCCB $\int i^2 dt$ through the interruption time should be within twice the permissible $\int i^2 dt$ of the element.

Diodes are generally stronger against overcurrent than thyristors, and since diodes can handle larger $I^2 \cdot t$, protection is easier.

Fig. 7.17 shows the protection coordination situation of a selection of devices, plotted together with the thyristor current-surge withstand curve. AC-side

protection (MCCB1, Fig. 7.15) is presented, but the DC-protection case (MCCB2) can be plotted in the same way.

Region 2 in Fig. 7.17 is the area of overcurrent for which protection is effected by the MCCB. For protection of region 1, an overload relay is effective, and for region 2, inductance L must be relied on to limit the fault-current rise rate, or a high-speed current-limiting fuse must be used. Practical considerations, including economy and the actual likelihood of faults in the regions concerned, may dictate the omission of the protective devices for regions 1 and 3, in many cases. The lower the instantaneous-trip setting of the MCCB, the wider the region 2 coverage becomes.

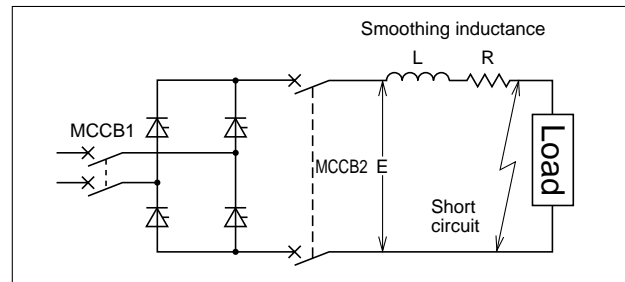

Fig. 7.15 Thyristor Short Circuit

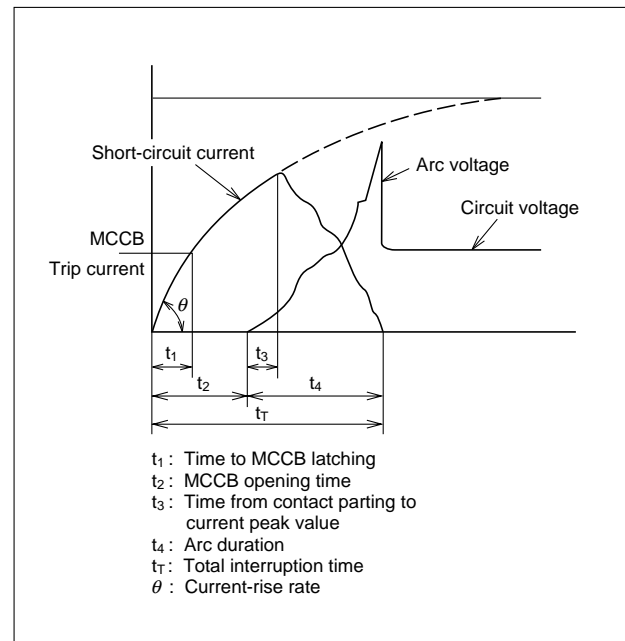

Fig. 7.16 Thyristor Short-Circuit Interruption

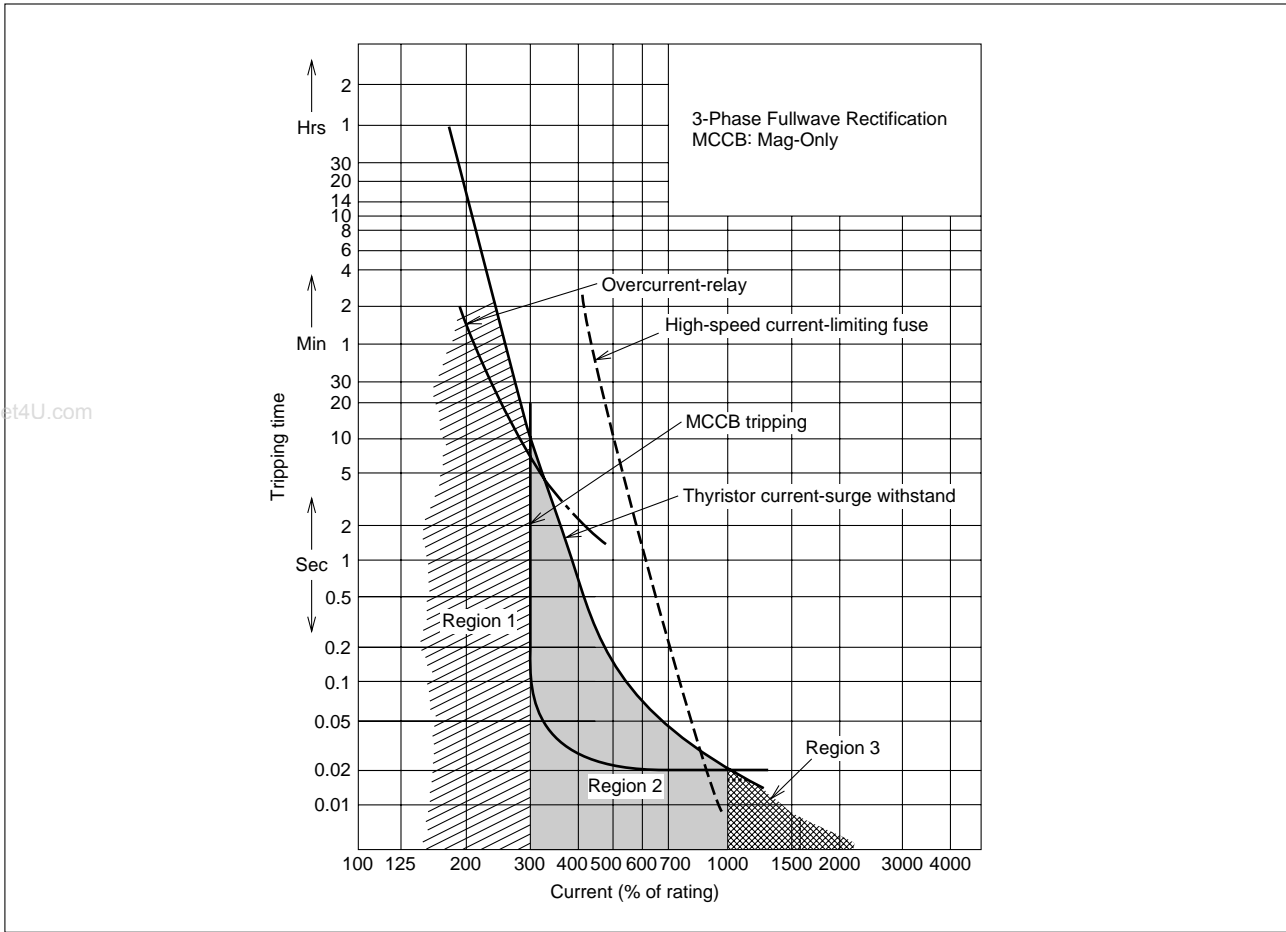

Fig. 7.17 Thyristor and Protector Operating Curves

3. Element Breakdown in Thyristor-Leonard Systems
In this system of DC motor control, if power outage or commutation failure due to a thyristor control-circuit fault occurs during inversion (while motor regenerative power is being returned to the AC supply), the DC motor, acting as a generator while coasting, will be connected to a short-circuit path, as in Fig. 7.18. For thyristor protection, MCCBs must be placed in the DC side, as shown.

A Mag-Only MCCB with a tripping current of about 3 times the rated current is employed, either 3- or 4-pole, series-connected as shown in Fig. 7.20. Since the element short-circuit current is the same as the MCCB current, circuit protection is effected provided that the $\int i^2 dt$ limit for the element is larger than that for the MCCB interruption duration. This must be established by test.

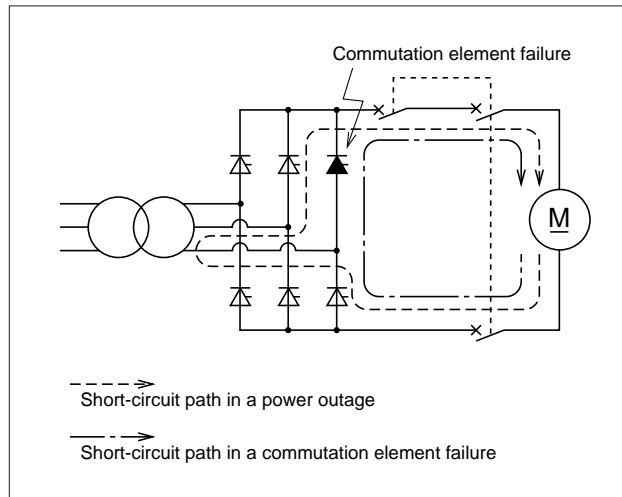

Fig. 7.18 Ward-Leonard Thyristor Protection

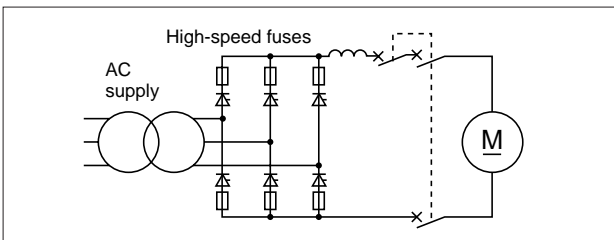

Fig. 7.19 High-Speed Fuses for Thyristor-Circuit Protection

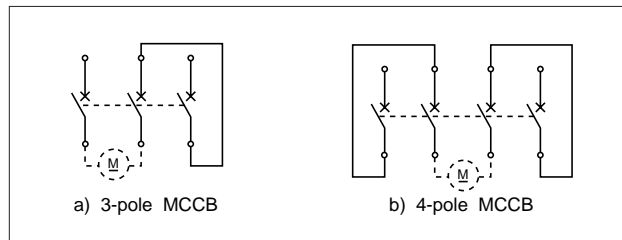

Fig. 7.20 Series Connection of MCCB Poles

Fig. 7.19 shows connection of high-speed fuses for protection against thyristor breakdown that would otherwise result in short-circuit flow from the AC supply side.

4. MCCBs for Lamp Mercury-Lamp Circuits

The ballasts (stabilizers) used in this type of lamp cover a variety of types and characteristics. For 200V applications (typical), choke-coil ballasts are used. For 100V applications a leakage-transformer ballast is employed. Normal ballasts come in low power-factor versions and high power-factor versions, with correction capacitors. More sophisticated types include the constant-power (or constant-output) type, which maintains constant lamp current both in starting and normal running, and flickerless types, which minimize the flicker attendant on the supply frequency.

In selecting an MCCB where normal (high or low PF) ballasts are to be used, the determining factor is the starting current, which is about 170% of the stable running current. In the cases of constant-power or flickerless types, the determining factor is the normal running current, which is higher than the starting cur-

rent. For MCCB selection, the latter types can be regarded as lighting and heating general loads, as previously discussed.

For selection of MCCBs for regular ballasts, the 170% starting current is assumed to endure for a maximum of 5 minutes. MCCBs of 100A or less frame size have a tripping value very close to rating for overloads of duration of this order, so that the MCCB rating should be the nearest standard value above 170% of the stable running current. MCCBs of above 100A frame size can handle a current of around 120% of the rating for 5 minutes without tripping; thus the nearest standard MCCB rating above $\frac{1.7}{1.2} = 1.4$ times the stable-running current of the lamp load is the suitable protector.

As an example, consider MCCB selection for 10 units of 100W, 100V, 50Hz general-purpose high power-factor mercury lamps. The stable-running current per lamp is 1.35A. Thus:

$1.35 \times 10 \times 1.7 = 23\text{A}$, and the selection becomes NF30-SP, 30A rated.

7.8 MDU Breaker

Structure and Motion

The MDU breaker is a circuit breaker equipped with the MDU (Measuring Display Unit) which measures and digitally displays electric circuit information. Combining the circuit breaker, CT, VT and measuring display unit, saves space and wiring, allows monitoring of various electric circuits and the energy load conditions.

7.8.1 Measurement

(a) Motion

As shown in Fig. 7.21, the electric current of each phase is transformed by the primary CT and inputted into the overload relay circuit for an electronic NFB. The electric current is transformed by the secondary CT and sent to the measuring display unit, MDU. Line voltage is converted to a signal in proportion to the voltage signal by resistance, transformed by the VT equivalent CT and inputted into the MDU. The MDU measures and displays by the electric current and voltage signals. Fig. 7.22 shows the internal block diagram of a model without voltage/electric power measuring functions. The frequency detection circuit provides an electric circuit frequency for measurement calculation.

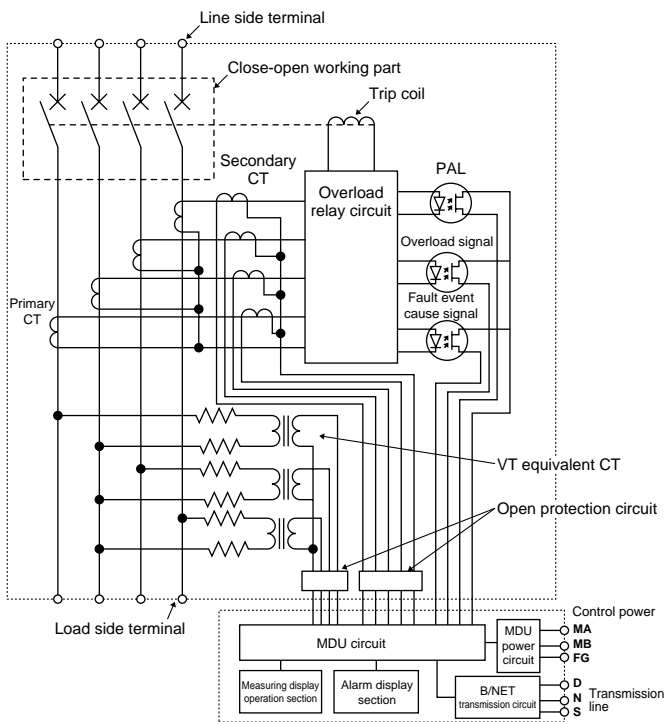

Fig. 7.21 MDU Breaker Circuit Diagram

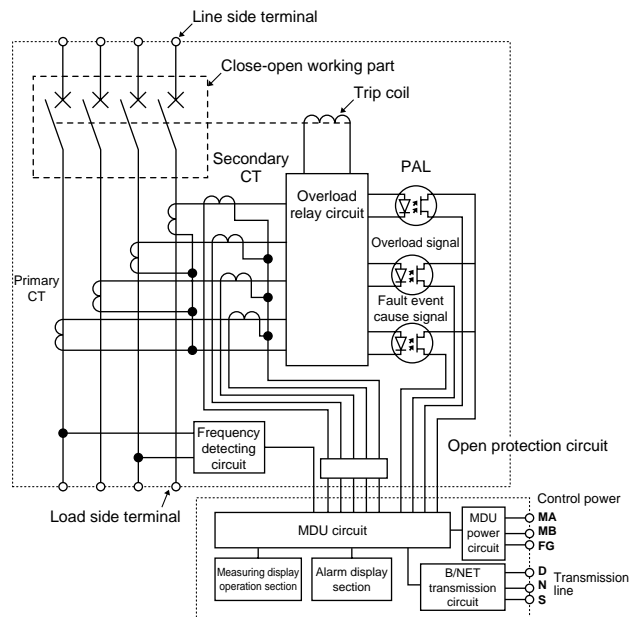

Fig. 7.22 MDU Breaker Circuit Diagram (without voltage and electric power measurement)

MDU converts the electric current and voltage signals from CT and VT into the voltage signal through the I/V conversion section. This signal is selected by a multiplexer and digitized at an A/D conversion section for digital calculation by a microcomputer. The CPU performs effective value calculation, demand calculation, electric power calculation, electric energy accumulation and harmonic calculation, etc.

The items to be measured are load current, line voltage, electric power, electric energy and harmonic current (3rd, 5th, 7th and ALL). It allows easy confirmation of electric circuit conditions and precise and efficient

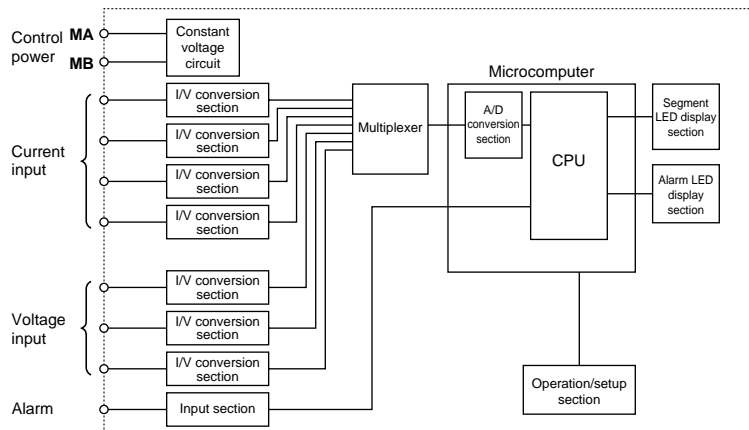

Fig. 7.23 MDU Block Diagram

energy management. Table 7.6 shows all the items. Sampling for measurement of voltage, electric current and electric power takes place once every several seconds, and the measured values are subject to calculation of the measurement values, such as the present values and average value, etc. Since the average value and electric energy are calculated from the sampling value measured once every several seconds, care should be taken when there is a breaking load such as a resistance welder. Electric energy cannot be used to provide data for contracts or verification.

(b) Measurement precision

The precision (allowance) of a measurement unit means the rate of errors against measurement range expressed as a percentage. The precision of electric current and voltage, etc. for MDU is equivalent to JISC1111 and it is the rate of errors against the rated current and voltage of measurement expressed as a percentage. Also, the precision of the electric power and electric energy is shown as a rate of errors against the rated current and voltage of measurement.

Table 7.6 Measurement Item List

Item	Applicable models			
	NF400-SEP NF400-HEP	NF400-SEP NF400-HEP Power provided	NF600-SEP NF600-HEP	NF800-SEP NF800-HEP
Load current of each phase, precision $\pm 2.5\%^{*1}$ Present value, average value, maximum average value	●	●	●	●
Line voltage, precision $\pm 2.5\%^{*1}$ Present value, average value, maximum average value	—	●	●	●
Harmonic load current 3rd, 5th, 7th and ALL Precision $\pm 2.5\%^{*1}$ Present value, maximum value, average value, maximum average value	●	●	●	●
Electric power, precision $\pm 2.5\%^{*1}$ Present value, average value, maximum average value	—	●	●	●
Electric energy accumulated, precision $\pm 2.5\%^{*2}$	—	●	●	●
Fault event current/fault event cause	●	●	●	●
Measuring rated current	400A	400A	600A	800A
Measuring rated voltage	440V	440V	440V	440V
Maximum measuring current	800A	800A	1200A	1600A
Maximum measuring voltage	690V	690V	690V	690V
Alarm(LED Indication)	PAL OVER			
B/NET transmission(option)	Load current of each phase, line voltage, electric power, electric energy, ALL harmonic current, fault event current/fault event cause Alarm PAL			
Electric energy accumulated pulse output(option)	Solid straight relay no voltage contact a DC24V/AC100 * 200V 20mA Pulse range 0.35 to 0.45sec Pulse unit 1, 10, 100, 1000, 10000, kWh=/Pulse			
Control power	AC100-240V 50/60Hz DC100V 200V 12VA			

*1 Conforms to JISC1111.

*2 It is not a power average/supply value obtained by Measurement Method.

*3 B/NET transmission and electric energy accumulated pulse output cannot be mounted simultaneously.

(c) External appearance and mounting of MDU

An example of the external appearance of MDU is shown in Fig. 7.24 and Fig. 7.25 showing the mounting structure.

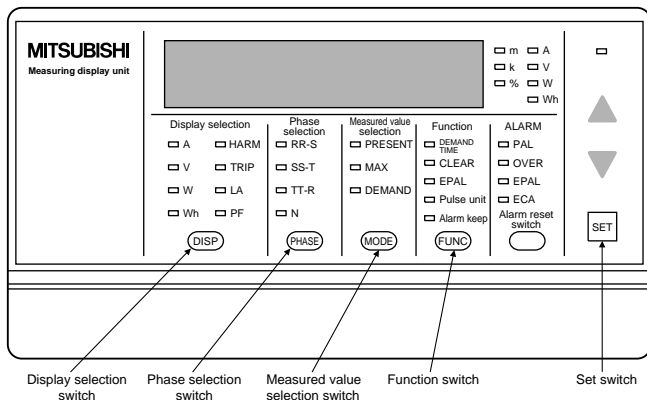

Fig. 7.24 Example of the NF600-SEP 3P MDU Display

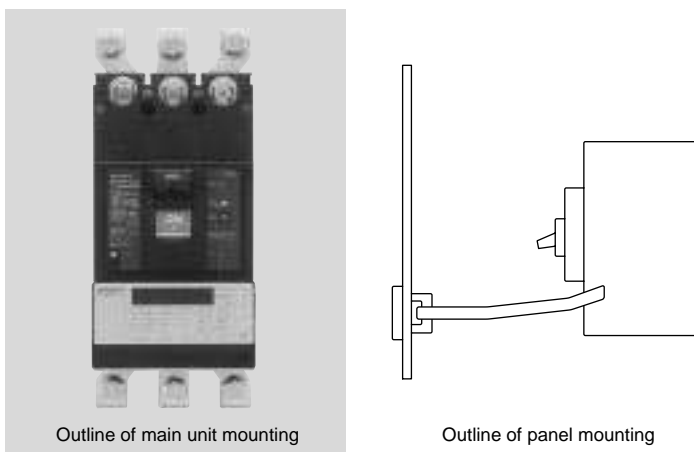

Fig. 7.25 Mounting

An average value is a value close to an average within the demand time limits. Also, demand time limit (t_0) means a period until measuring display value (I_0) indicates 95% of input (I) when a certain input (I) is continuously turned on. It takes about three times as long as the time limit (t_0) until it indicates 100% of input (I) (Fig. 7.26).

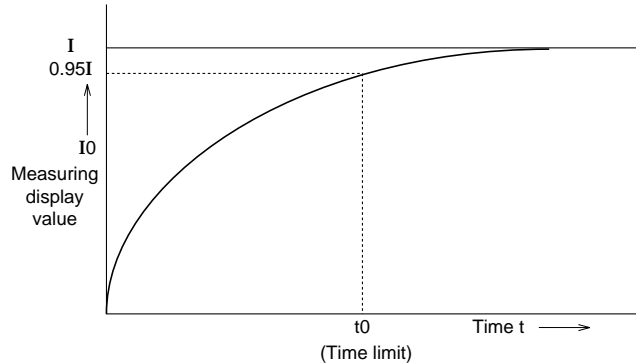

Fig.7.26 Demand Characteristics

7.8.2 Maintenance function

In the fault event of a circuit breaker trip, the MDU breaker measures the fault event cause and the fault event current that is load current, and records them in a non-volatile memory device in order to identify the cause of the fault event and make a prompt recovery. Also, since it records the maximum values of demand current and hourly electric energy, etc. in a non-volatile memory device, it is useful for understanding the condition of power consumption. The fault event cause indicates either an overload or a short circuit.

7.8.3 Alarm output function

A circuit breaker monitors various alarm outputs and turns on an alarm LED. The alarms are the PAL, the load current pre-alarm and OVER, the overload alarm.

7.8.4 Transmission function

The measured data is transmitted through B/NET, MITSUBISHI distribution control network (option). It can obtain the unit management data for energy saving and automatically collect the electric equipment operation data for preventive maintenance. Furthermore, electric energy accumulated can output as a pulse output (option). It enables the direct input into a sequencer realizing labor saving of power consumption control by the sequencer.

Withstand Voltage and Insulation Resistance Tests

As VT is connected between the poles on the load side of a circuit breaker, voltage resistance tests between the electrodes on the load side cannot be conducted (shown as X in Table 7.7.) Although an insulation resistance test at DC500V does not result in damage to the circuit breaker, the insulation resistance value measured by the test will be low (shown as Δ .) There is no problem regarding the voltage and insulation resistance tests between the circuit breaker main circuit and earth.

Table 7.7 Places for Withstand Voltage and Insulation Resistance Tests

Measured Point/test		Insulation resistance measurement		Withstand voltage test		
		ON	OFF	ON	OFF	
State of handle		○	○	○	○	
Between line part and earth		○	○	○	○	
Between different poles	Line side	Between left and middle poles	Δ	○	×	○
		Between middle and right poles	Δ	○	×	○
		Between left and right poles	Δ	○	×	○
	Load side	Between middle and neutral poles	Δ	○	×	○
		Between left and middle poles	Δ	Δ	×	×
		Between middle and right poles	Δ	Δ	×	×
		Between left and right poles	Δ	Δ	×	×
Between middle and neutral poles	Δ	Δ	×	×		
Between line and load side terminal		—	○	—	○	

7.9 Selection of MCCBs in inverter circuit

7.9.1 Cause of distorted-wave current

Distorted-wave current is caused by factors such as the CVCF device of a computer power unit, various rectifiers, induction motor control VVVF device corresponding to more recent energy-saving techniques, etc, wherein thyristor and transistor are used. Any of these devices generates DC power utilizing the switching function of a semiconductor and, in addition, transforms the generated DC power into intended AC power. Generally, a large capacity capacitor is connected on its downstream side from the rectification circuit for smoothing the rectification, so that the charged current for the capacitor flows in pulse form into the power circuit. Because voltage is chopped at high frequency in AC to DC transforming process, load current to which high frequency current was superimposed by chopping basic frequency flows into the load line. This paragraph describes the VVVF inverter, of these devices, which will develop further as main control methods for induction motors currently in broad use in various fields. Fig. 7.27 illustrates an example of MCCBs application to inverter circuit. Two control methods of PAM (Pulse Amplitude Modulation) and PWM (Pulse Wide Modulation) are available for the VVVF inverter and generating higher harmonic wave components differs depending on the difference between the control methods. As seen from Tables 7.9 and 7.10, this harmonic wave component of input current can be made smaller (improved) by inputting DC reactor (DCL) or AC reactor (ACL). Further, in the case of the output current waveform in Fig. 7.29, the PWM generates higher harmonic wave components than that of the PAM.

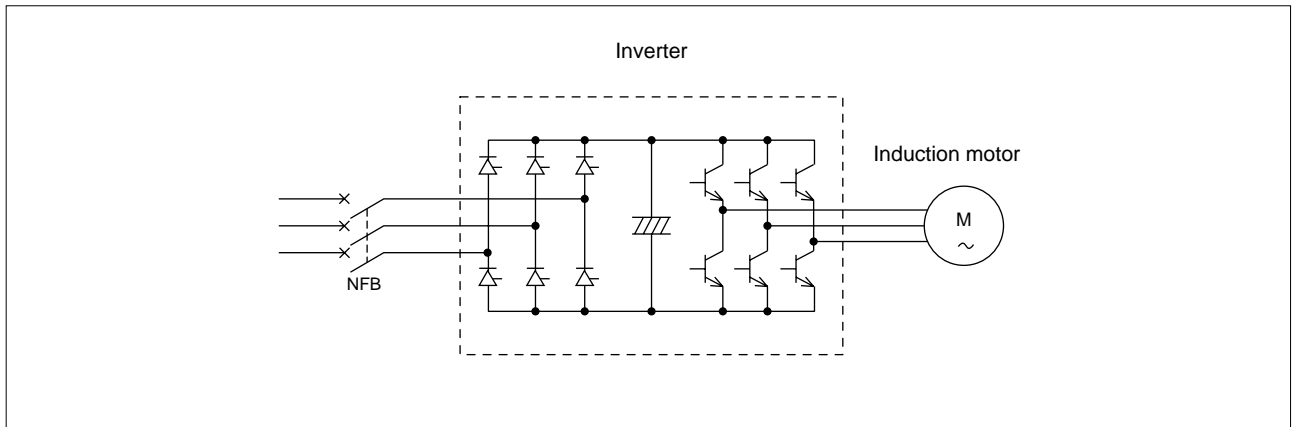

Fig.7.27 Example of MCCBs Application to Inverter Circuit

7.9.2 Selection of MCCBs

MCCBs characteristic variations and temperature rises dependent on distortion of the current wave must be considered when selecting MCCBs for application to an inverter circuit (power circuit). The relation of rated current I_{NFB} to load current I of MCCBs is selected as follows from the MCCBs tripping system.

$$I_{NFB} \geq K \times I$$

Thermal acting solenoid type (bimetal system) and electronic type (real value detection) are both real current detection systems which enable exact overload protection even under distorted-wave current. Due to the above explanation, it is advantageous to select real current detection type MCCBs.

Table 7.8 Reduction Rate

MCCBs tripping system	Reduction rate K
Thermalacting solenoid type (bimetal system)	1.4
(Note 2) Thermal acting solenoid type (CT system)	2
(Note 1) Perfect solenoid type	1.4
Electronic type (Real value detection)	1.4
(Note 3) Electronic type (Peak value detection)	2

This table is subject to the current which meets the following requirements.

- ① Distortion percent = $\frac{\text{Real value of total harmonic wave component}}{\text{Real value of basic frequency}} \times 100 \leq 100\%$ or less
- ② Peak factor = $\frac{\text{Peak value}}{\text{Real value}} \leq 3$ or less
- ③ Higher harmonic wave components are mainly No.7 or a lower harmonic wave.

- Notes:
1. The characteristics of perfect solenoid type MCCBs vary significantly depending on wave distortion. Therefore, use of thermal acting solenoid type MCCBs is recommended.
 2. NF2000-S, NF2500-S, NF3200-S, NF4000-S
 3. NFE2000-S, NFE3000-S, NFE4000-S

Table 7.9 Data of High Harmonic Wave Current Content in Inverter Power Circuit (Example)

High harmonic wave degree	High harmonic wave current content (%)			
	P W M		P A M	
	No ACL (Standard)	With power factor modifying ACL	With standard ACL	With power factor modifying ACL
Basic	81.6	97.0	83.6	97.2
2	–	–	–	–
3	3.7	–	2.5	–
4	–	–	–	–
5	49.6	21.9	48.3	21.7
6	–	–	–	–
7	27.4	7.1	23.7	7.0
8	–	–	–	–
9	–	–	–	–
10	–	–	–	–
11	7.6	3.9	6.2	3.7
12	–	–	–	–
13	6.7	2.8	4.7	2.6

Note: No DCL Output frequency 60Hz , subject to 100% load

Table 7.10 Peak Factor of Inverter Input Current

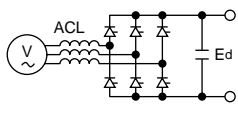
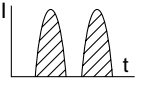
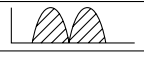
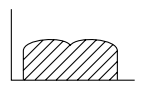
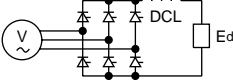
Circuit	Input current			
	Power factor	Waveform factor	Peak factor	Waveform (half wave portion)
with ACL Large → ACL → Small 	Below 58.7	Above 1.99	Above 2.16	
	58.7%	1.99	2.16	
	58.7–83.5%	1.99–1.27	2.16–1.71	
	83.5%	1.27	1.71	
	83.5–95.3%	1.27–1.23	1.71–1.28	
With DCL 	95.3%	1.23	1.28	

Power factor = (DC voltage x DC) / ($\sqrt{3}$ x AC effective voltage x AC effective current)

Waveform factor = (Effective value) / (Mean value)

Peak factor = (Max value) / (Effective value)

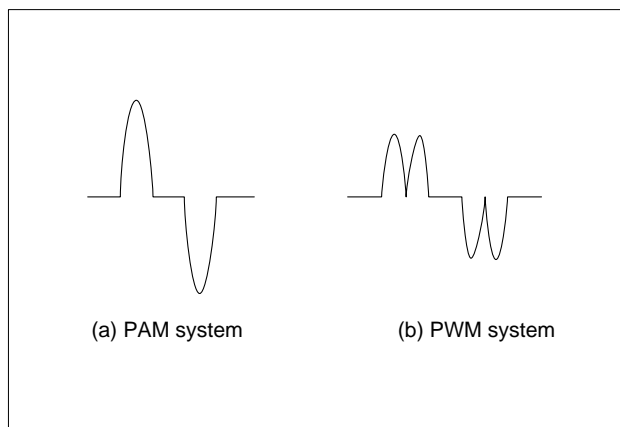

Fig.7.28 Inverter Input Current

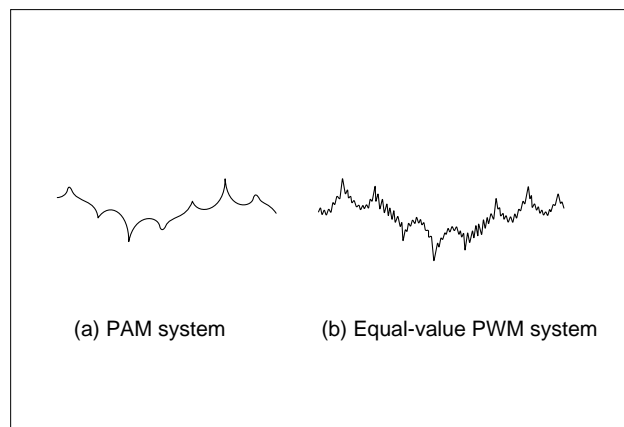

Fig.7.29 Inverter Output Current

8. ENVIRONMENTAL CHARACTERISTICS

8.1 Atmospheric Environment

Abnormal environments may adversely affect performance, service life, insulation and other aspects of MCCB quality. Where service conditions differ substantially from the specified range as below, derating of performance levels may result.

1. Ambient temperature range $-10^{\circ}\text{C} \sim +40^{\circ}\text{C}$ (Average temperature for 24 hours, however, shall not be higher than 35°C .)
 2. Relative humidity 85% max. with no dewing
 3. Altitude 2,000m max.
 4. Ambient No excessive water or oil vapour, smoke, dust, salt content, corrosive substance, vibration, and impact
- Expected service life (MTTF) under the above conditions is 15 years.

8.1.1 High Temperature Application

To comply with relevant standards, all circuit breakers are calibrated at 40°C . If the circuit breaker is to be used in an environment where the ambient temperature is likely to exceed 40°C please apply the derating factor shown in table 8.2.

For example: To select a circuit breaker for use on a system where the full load current is 70A in an ambient temperature at 50°C then from table 8.2



$$\frac{70\text{A}}{0.9} = 77.8\text{A}$$

Select a circuit breaker with a trip unit adjustable from 80-100A or fixed at 100A.

Table 8.2 MCCB Derating

Ambient Temperature ($^{\circ}\text{C}$)	Derating factor
50	0.9
55	0.8
60	0.7

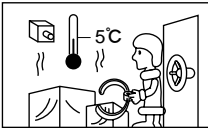
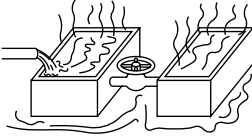
Table 8.1 Abnormal Environments, and Countermeasures

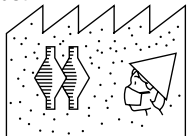
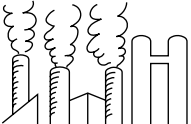
Environment	Trouble	Countermeasures
<p>High temperature</p> 	<ol style="list-style-type: none"> 1. Nuisance tripping 2. Insulation deterioration 	<ol style="list-style-type: none"> 1. Reduce load current (derate). 2. Avoid ambients above 60°C.
<p>Low temperature</p> 	<ol style="list-style-type: none"> 1. Condensation and freezing 2. Low-temperature fragility in shipping (around -40°C) 	<ol style="list-style-type: none"> 1. Install heater for defrosting and drying. 2. Ship tripped, or if not possible, OFF.
<p>High humidity</p> 	<ol style="list-style-type: none"> 1. Insulation resistance loss 2. Corrosion 	<ol style="list-style-type: none"> 1. Use MCCB enclosure such as Type W. 2. Inspect frequently, or install high-corrosion-resistant MCCBs.
<p>High altitude</p> 	<ol style="list-style-type: none"> 1. Reduced temperature, otherwise no problem up to 2,000m 	<ol style="list-style-type: none"> 1. See "Low temperature", above.
<p>Dirt and dust</p> 	<ol style="list-style-type: none"> 1. Contact discontinuity 2. Impaired mechanism movement 3. Insulation resistance loss 	<ol style="list-style-type: none"> 1. Use Type I MCCB enclosure.
<p>Corrosive gas, salt air</p> 	<ol style="list-style-type: none"> 1. Corrosion 	<ol style="list-style-type: none"> 1. Use Type W MCCB enclosure or install high-corrosion-resistant MCCBs.

8.1.2 Low Temperature Application

In conditions where temperatures reach as low as -5°C special MCCBs are usually required. Mitsubishi, however, have tested their standard MCCBs to temperatures as low as -10°C without any detrimental effects.

For conditions where temperatures drop below -10°C special MCCBs must be used.

If standard MCCBs experience a sudden change from high temperature, high humidity conditions to low temperature conditions, there is a possibility of ice forming inside the mechanism. In such conditions we recommend that some form of heating be made available to prevent mal-operation.

In conditions of low temperature MCCBs should be stored in either the tripped or OFF position.

Low Temperature MCCBs

Special low temperature MCCBs are available that can withstand conditions where temperatures fall to as low as -40°C . These special MCCBs are available in sizes up to 1200A in the standard series and above 50A in the compact series.

8.1.3 High Humidity

In conditions of high humidity the insulation resistance to earth will be reduced as will the electrical life.

For applications where the relative humidity exceeds 85% the MCCB must be specially prepared or special enclosures used. Special preparation includes plating all metal parts to avoid corrosion and special painting of insulating parts to avoid the build up of mildew.

There are two degrees of tropicalisation:

Treatment 1- painting of insulating material to avoid build up of mildew plus special plating of metal parts to avoid corrosion.

Treatment 2- painting of insulating material to avoid build up of mildew only.

8.1.4 Corrosive Atmospheres

In the environment containing much corrosive gas, it is advisable to use MCCB of added corrosion resistive specifications.

For the breakers of added corrosionproof type, corrosion-proof plating is applied to the metal parts.

Where concentration of corrosive gas exceeds the level stated below, it is necessary to use MCCB of added corrosion resistive type being enclosed in a water-proof type enclosure or in any enclosure of protective structure.

Allowable containment for corrosive gas.

H_2S 0.01ppm SO_2 0.05ppm
 NH_3 1ppm

8.1.5 Affecting of Altitude

When MCCBs are used at altitudes exceeding 2000m above sea level, the effects of a drop in pressure and drop in temperature will affect the operating performance of the MCCBs. At an altitude of 2200m, the air pressure will drop to 80% and it drops to 50% at

5500m, however interrupting capacity is unaffected. The derating factors that are applicable for high altitude applications are shown in table 8.3. (According to ANSI C 37.29-1970)

Table 8.3 Derating Factors for High Altitude Applications

Altitude	Rated current	Rated voltage
3000m	0.98	0.91
4000m	0.96	0.82
5000m	0.94	0.73
6000m	0.92	0.65

For example: NF800-SEP on 4000m

1. Voltage

The rated operating voltage is AC690V. You should derate by $690 \times 0.82 = 565.8\text{V}$. It means that you can use this NF800-SEP up to AC565.8V rated voltage.

2. Current

The rated current is 800A. You should derate by $800 \times 0.96 = 768\text{A}$. It means that you can use this NF800-SEP up to 768A rated current.

8.2 Vibration-Withstand Characteristics

8.2.1 The Condition of Test

- Installation position and Direction of vibration
 - Every vertical and horizontal at vertical installed (as shown in Fig. 8.1)
- The position of MCCBs and vibration time
 Forty minutes in each position (ON, OFF and TRIP)
- Vibration criteria
 - Frequency 5~100Hz
 - Vibration acceleration 2.2g
 - Period 10min./cycle

8.2.2 The Result of Test

The samples must show no damage and no change of operating characteristic (200% release), and must not be tripped or switched off by the vibration.

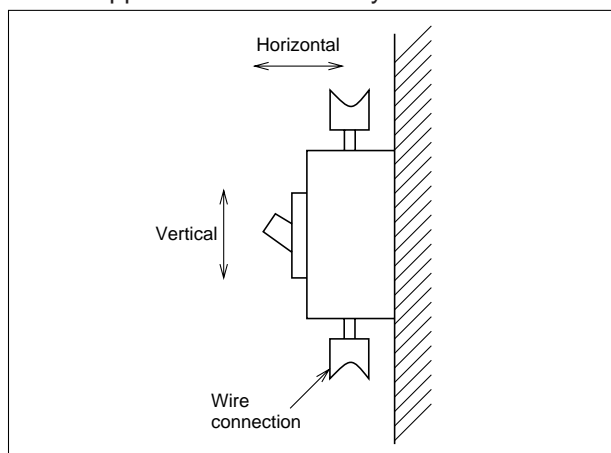

Fig. 8.1 Applied Vibration

8.3 Shock-Withstand Characteristics

8.3.1 The Condition of Test

1. MCCBs are drop-tested, as described in Fig. 8.2. The arrows show the drop direction.
2. The samples are set to ON, with no current flowing.

8.3.2 The Result of Test (as Shown in Table 8.4)

The samples must show no physical damage, and the switched condition must not be changed by the drop in any of the drop-attitudes tested.

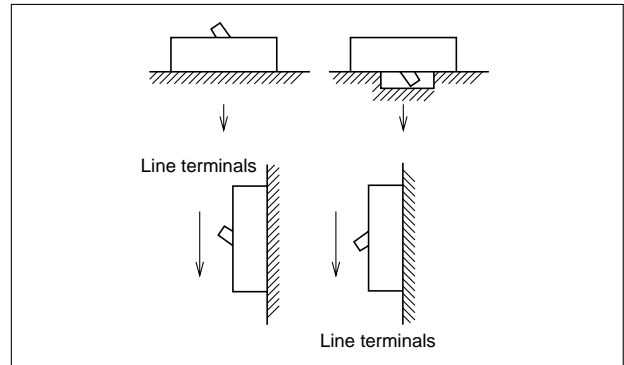

Fig. 8.2 Drop-Test Attitudes

The judgment of failure:

- A case the switched condition changed from ON to OFF
- A case the switched condition changed from ON to Trip
- A case the sample shows physical damage

Table 8.4 Shock-Withstand Characteristics of Mitsubishi MCCB

Series	Type	No tripped (G)	No damage (G)	
BH	BH-K BH-P, BH-S, BH-PS, BH-D	15	50	
MB	MB30-CS	15		
	MB30-SP MB50-CP MB50-SP MB100-SP MB225-SP	20		
NF	NF30-SP NF50-HP NF50-HRP NF60-HP NF100-SP NF100-SEP NF100-HP NF100-HEP NF160-SP NF160-HP NF250-SP NF250-SEP NF250-HP NF250-HEP NF400-SP NF400-SEP NF400-HEP NF400-REP NF630-SP NF630-SEP NF630-HEP NF630-REP NF800-SDP NF800-SEP NF800-HEP NF800-REP NF1000-SS NF1250-SS NF1600-SS NF2000-S NF2500-S NF3200-S NF4000-S NFE2000-S NFE3000-S NFE4000-S	20		
	C	NF30-CS		15
		NF50-CP NF60-CP		20
		NF100-CP NF250-CP NF400-CP NF630-CP NF800-CEP		20
U	NF100-UP NF100-RP NF225-UP NF225-RP NF400-UEP NF630-UEP NF800-UEP NF1250-UR	20		

※: 1G = 980cm/s²

9. SHORT-CIRCUIT CURRENT CALCULATIONS

9.1 Purpose

Japanese and international standards require, in summary, that an overcurrent protector must be capable of interrupting the short-circuit current that may flow at the location of the protector. Thus it is necessary to establish practical methods for calculating short-circuit currents for various circuit configurations in low-voltage systems.

9.2 Definitions

1. % Impedance

The voltage drop resulting from the reference current, as a percentage of the reference voltage (used for short-circuit current calculations by the % impedance method).

$$\% \text{ impedance} = \frac{\text{voltage drop at capacity load}}{\text{reference voltage}} \times 100 (\%)$$

(Reference voltage: 3-phase – phase voltage)

2. Reference Capacity

The capacity determined from the rated current and voltage used for computing the % impedance (normally 1000kVA is used).

3. Per-Unit Impedance

The % impedance expressed as a decimal (used for short-circuit current calculations by the per-unit method).

4. Power Supply Short-Circuit Capacity

3-phase supply (MVA) = $\sqrt{3}$ x rated voltage (kV) x short circuit current (kA)

5. Power Supply Impedance

Impedance computed from the short-circuit capacity of the supply (normally indicated by the electric power company; if not known, it is defined, together with the X/R ratio, as 1000MVA and X/R=25 for a 3-phase supply (from NEMA.AB1).

6. Motor contribution Current

While a motor is rotating it acts as generator; in the event of a short circuit it contributes to increase the total short-circuit current. (Motor current contribution must be included when measuring 3-phase circuit short-circuit current).

7. Motor Impedance

The internal impedance of a contributing motor. (A contributing motor equal to the capacity of the transformer is assumed to be in the same position as the transformer, and its % impedance and X/R value are assumed as 25% and 6 (from NEMA.AB1).

8. Power Supply Overall Impedance

The impedance vector sum of the supply (Z_L), the transformer (Z_T) and the motor (Z_M).

Overall impedance of 3-phase supply

$$(Z_s) = \frac{(Z_L + Z_T) \cdot Z_M}{Z_L + Z_T + Z_M} (\% \Omega)$$

9. Short-Circuit Current Measurement Locations

In determining the interruption capacity required of

the MCCB, generally, the short-circuit current is calculated from the impedance on the supply side of the breaker.

Fig. 9.1 represents a summary of Japanese standards.

9.3 Impedances and Equivalent Circuits of Circuit Components

In computing low-voltage short-circuit current, all impedances from the generator (motor) to the short-circuit point must be included; also, the current contributed by the motor operating as a load. The method is outlined below.

9.3.1 Impedances

1. Power Supply Impedance (Z_L)

The impedance from the power supply to the transformer-primary terminals can be calculated from the short-circuit capacity specified by the power company, if known.

Otherwise it should be defined, together with X/R, as 1000MVA and X/R=25 for a 3-phase supply. Note that it can be ignored completely if significantly smaller than the remaining circuit impedance.

2. Transformer Impedance (Z_T)

Together with the line impedance, this is the largest factor in determining the short-circuit current magnitude. Transformer impedance is designated as a percentage for the transformer capacity; thus it must be converted into a reference-capacity value (or if using Ohm's law, into an ohmic value).

Tables 9.1 show typical impedance values for transformers, which can be used when the transformer impedance is not known.

3. Motor Contribution Current and Impedance (Z_M)

The additional current contributed by one or more motors must be included, in considering the total 3-phase short-circuit current. Motor impedance depends on the type and capacity, etc.; however, for typical induction motors, % impedance can be taken as 25% and X/R as 6. The short-circuit current will thus increase according to the motor capacity, and the impedance up to the short-circuit point. The following assumptions can normally be made.

- The total current contribution can be considered as a single motor, positioned at the transformer location.
- The total input (VA) of motor contribution can be considered as equal to the capacity of the transformer (even though in practice it is usually larger). Also, both the power factor and efficiency can be assumed to be 0.9; thus the resultant motor contribution output is approximately 80% of the transformer capacity.
- The % impedance of the single motor can be considered as 25% and the X/R as 6.

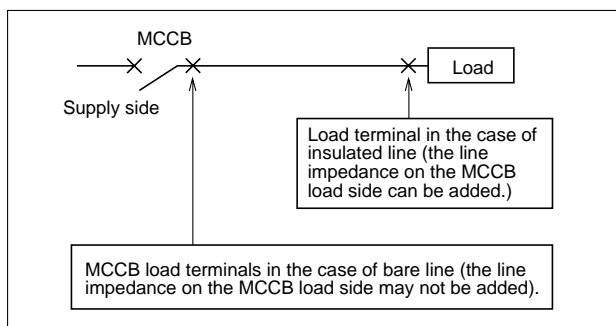

Fig. 9.1 Short-Circuit Locations for Current Calculations

Table 9.1 Impedances of 3-Phase Transformers

Transformer capacity (kVA)	Impedance (%)	
	%R	%X
50	1.81	1.31
75	1.78	1.73
100	1.73	1.74
150	1.61	1.91
200	1.63	2.60
300	1.50	2.82
500	1.25	4.06
750	1.31	4.92
1000	1.17	4.94
1500	1.23	5.41
2000	1.13	5.89

4. Line and Bus-Duct Impedance (Z_W , Z_B)

Table 9.2 gives unit impedances for various configurations of wiring, and Table 9.3 gives values for ducting.

Since the tables give ohmic values, they must be converted, if the %-impedance method is employed.

5. Other Impedances

Other impedances in the path to the short-circuit point include such items as CTs, MCCBs, control devices, and so on. Where known, these are taken into consideration, but generally they are small enough to be ignored.

Table 9.2 Wiring Impedance

Cable size (mm ²)	Resistance (mΩ/m)	Reactance(mW/m)					
		50Hz			60Hz		
		2-or 3-core cables	1-core cables (close-spaced)	1-core cables (6cm-spaced)	2-or 3-core cables	1-core cables (close-spaced)	1-core cables (6cm-spaced)
1.5	12.10	0.1076	0.1576	0.2963	0.1292	0.1891	0.3555
2.5	7.41	0.1032	0.1496	0.2803	0.1238	0.1796	0.3363
4.0	4.61	0.0992	0.1390	0.2656	0.1191	0.1668	0.3187
6.0	3.08	0.0935	0.1299	0.2527	0.1122	0.1559	0.3033
10.0	1.83	0.0873	0.1211	0.2369	0.1048	0.1453	0.2843
16.0	1.15	0.0799	0.1043	0.2138	0.0959	0.1251	0.2565
25.0	0.727	0.0793	0.1014	0.2000	0.0952	0.1217	0.2400
35.0	0.524	0.0762	0.0964	0.1879	0.0915	0.1157	0.2254
50.0	0.387	0.0760	0.0924	0.1774	0.0912	0.1109	0.2129
70.0	0.268	0.0737	0.0893	0.1669	0.0884	0.1072	0.2001
95.0	0.193	0.0735	0.0867	0.1573	0.0882	0.1040	0.1888
120.0	0.153	0.0720	0.0838	0.1498	0.0864	0.1006	0.1798
150.0	0.124	0.0721	0.0797	0.1427	0.0865	0.0956	0.1712
185.0	0.0991	0.0720	0.0806	0.1356	0.0864	0.0967	0.1627
240.0	0.0754	0.0716	0.0818	0.1275	0.0859	0.0982	0.1530
300.0	0.0601	0.0712	0.0790	0.1195	0.0854	0.0948	0.1434
400.0	0.0470	—	0.0777	0.1116	—	0.0932	0.1339
500.0	0.0366	—	0.0702	0.1043	—	0.0843	0.1252
630.0	0.0283	—	0.0691	0.0964	—	0.0829	0.1157

Notes: 1. Resistance values per IEC 228

2. Reactance per the equation: $L(\text{mH/km}) = 0.05 + 0.4605 \log_{10} D/r$ (D =core separation, r =conductor radius)

3. Close-spaced reactance values are used.

Table 9.3 Bus-Duct Impedance

Rated current (A)	Resistance (mΩ/m) at 20°C	Reactance (mΩ/m)	
		50Hz	60Hz
400	0.125	0.0250	0.0300
600	0.114	0.0231	0.0278
800	0.0839	0.0179	0.0215
1000	0.0637	0.0139	0.0167
1200	0.0397	0.0191	0.0230
1500	0.0328	0.0158	0.0190
2000	0.0244	0.0118	0.0141
2500	0.0192	0.0092	0.0110
3000	0.0162	0.0077	0.0092

9.3.2 Equivalent Circuits

1. Three-Phase

Based on the foregoing assumptions for motors, the equivalent circuits of Fig. 9.2 can be used for calculating 3-phase short-circuit current. The motor impedance (Z_M) can be considered as shunting the series string consisting of the supply (Z_L) and transformer (Z_T) impedances, by busbars of infinite short-circuit capacity. When the three impedances are summed, the total impedance and the resistive and reactive components are given as:

$$Z_S = \frac{(Z_L + Z_T) \cdot Z_M}{Z_L + Z_T + Z_M} = R_S + j X_S$$

$$R_S = \frac{[(R_L + R_T + R_M) \{R_M(R_L + R_T) - X_M(X_L + X_T)\}] + (X_L + X_T + X_M) \{X_M(R_L + R_T) + R_M(X_L + X_T)\}}{(R_L + R_T + R_M)^2 + (X_L + X_T + X_M)^2}$$

$$X_S = \frac{[(R_L + R_T + R_M) \{X_M(R_L + R_T) + R_M(X_L + X_T)\}] - (X_L + X_T + X_M) \{R_M(R_L + R_T) - X_M(X_L + X_T)\}}{(R_L + R_T + R_M)^2 + (X_L + X_T + X_M)^2}$$

Thus, when calculating the short-circuit current at various points in a load system, if the value Z_S is first computed, it is a simple matter to add the various wire or bus-duct impedances. Table 9.4 gives values of total supply impedance (Z_S), using transformer impedance per Table 9.1, power-supply short-circuit capacity of 1000MVA, and X/R of 25.

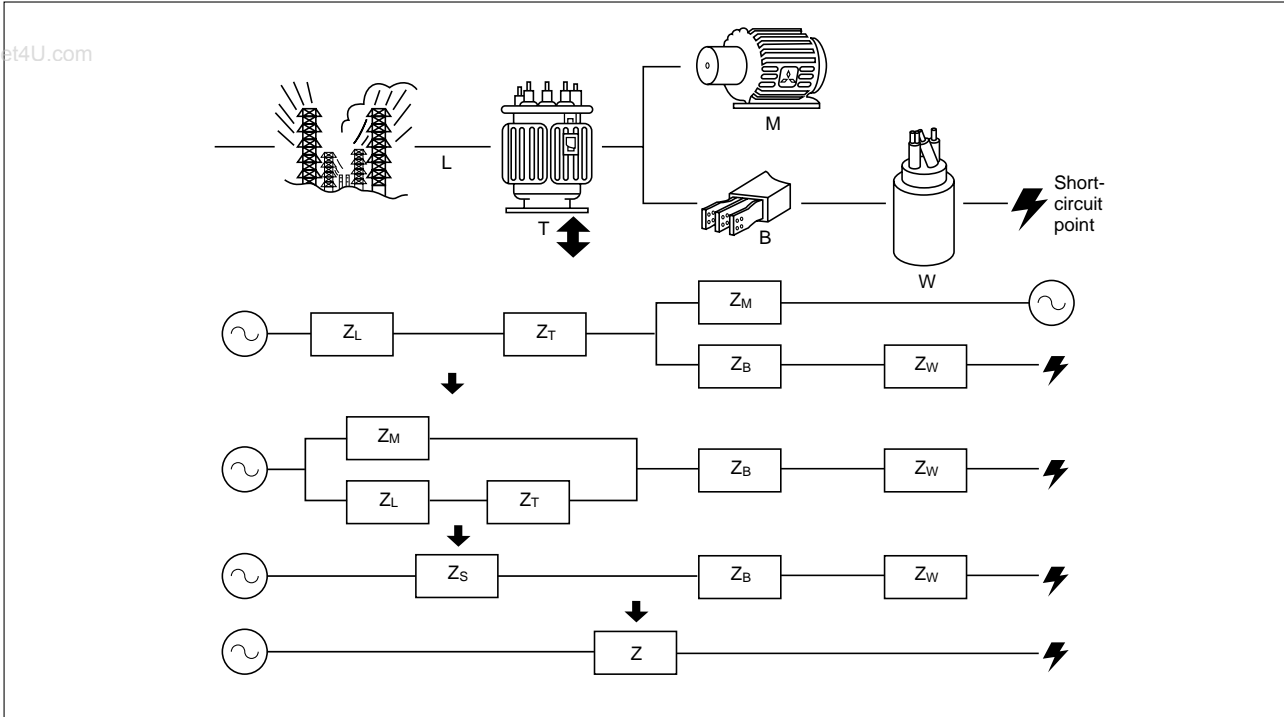

Fig. 9.2 3-Phase Equivalent Circuits

Table 9.4 Total Impedances for 3-Phase Power Supplies

Transformer capacity (kA)	Impedance based on 1000kVA(%)	Ohmic value (mΩ)	
		230V	440V
50	33.182 +j 26.482	17.553 +j 14.009	64.240 +j 51.269
75	21.229 +j 22.583	11.230 +j 11.946	41.099 +j 43.720
100	15.473 +j 17.109	8.185 +j 9.051	29.956 +j 33.123
150	9.56 +j 12.389	5.057 +j 6.554	18.508 +j 23.985
200	6.977 +j 12.15	3.691 +j 6.427	13.507 +j 23.522
300	4.306 +j 8.795	2.278 +j 4.653	8.336 +j 17.027
500	2.089 +j 7.27	1.105 +j 3.846	4.044 +j 14.074
750	1.427 +j 5.736	0.755 +j 3.034	2.763 +j 11.104
1000	0.969 +j 4.336	0.513 +j 2.294	1.876 +j 8.394
1500	0.671 +j 3.142	0.355 +j 1.662	1.299 +j 6.083
2000	0.467 +j 2.544	0.247 +j 1.346	0.904 +j 4.925

Notes: 1. Total power-supply impedance $Z_S = \frac{(Z_L + Z_T)Z_M}{Z_L + Z_T + Z_M}$

2. For line voltages (E') other than 200V, multiply the ohmic value by $\left(\frac{E'}{200}\right)^2$

9.4 Classification of Short-Circuit Current

A DC current (Fig. 9.3) of magnitude determined by the voltage phase angle at the instant of short circuit and the circuit power factor will be superimposed on the AC short-circuit current.

This DC component will rapidly decay; however, where a high-speed circuit-interruption device such as an MCCB or fuse is employed, the DC component must be considered. Further, the mechanical stress of the electric circuit will be affected by the maximum instantaneous short-circuit current; hence, the short-circuit current is divided, as below.

1. RMS Symmetrical Short-Circuit Current (I_s)

This is the value exclusive of the DC component; it is $A_s/\sqrt{2}$ of Fig. 9.3.

2. RMS Asymmetrical Short-Circuit Current (I_{as})

This value includes the DC component. It is defined as:

$$I_{as} = \sqrt{\left(\frac{A_s}{\sqrt{2}}\right)^2 + A_d^2}$$

Accordingly, when the DC component becomes maximum (i.e., $\theta - \phi = \pm \frac{\pi}{2}$, where the voltage phase angle at short circuit is θ , and the circuit power factor is $\cos\phi$), I_{as} will also become maximum $\frac{1}{2}$ cycle after the short circuit occurs, as follows:

$$I_{as} = I_s \cdot \sqrt{1 + 2e^{-\frac{2\pi R}{x}}} = I_s \cdot K_1, \text{ that is: } K_1 = \sqrt{1 + 2e^{-\frac{2\pi R}{x}}}$$

where K_1 is the single-phase maximum asymmetrical coefficient, and I_{as} can be calculated from the asymmetrical value and the circuit power factor. In a 3-phase circuit, since the voltage phase angle at switch-on differs between phases, I_{as} will do the same. If the average of these values is taken $\frac{1}{2}$ cycle later, to give the 3-phase average asymmetrical short-circuit current, the following relationship is obtained:

$$I_{as} = I_s \cdot \frac{1}{3} \left\{ \sqrt{1 + 2e^{-\frac{2\pi R}{x}}} + 2\sqrt{1 + \frac{1}{2}e^{-\frac{2\pi R}{x}}} \right\} = I_s \cdot K_3$$

$$\text{that is: } K_3 = \frac{1}{3} \left\{ \sqrt{1 + 2e^{-\frac{2\pi R}{x}}} + 2\sqrt{1 + \frac{1}{2}e^{-\frac{2\pi R}{x}}} \right\}$$

K_3 is the asymmetrical coefficient, derived from the symmetrical value and the circuit power factor.

3. Peak Value of Asymmetrical Short-Circuit Current

This value (I_p in Fig. 9.3) depends upon the phase angle at short circuit closing and on the circuit power factor; it is maximum when $\theta = 0$. It will reach peak value in each case, $\omega t = \frac{\pi}{2} + \phi$ after the short circuit occurrence. It can be computed as before, by means of the circuit power factor and the symmetrical short-circuit current.

$$I_p = I_s \left[1 + \sin\phi \cdot e^{-\left(\frac{\pi}{2} + \phi\right) \cdot \frac{R}{x}} \right] = I_s \cdot K_p$$

$$\text{thus: } K_p = \sqrt{2} \left[1 + \sin\phi \cdot e^{-\left(\frac{\pi}{2} + \phi\right) \cdot \frac{R}{x}} \right]$$

K_p , the peak asymmetrical short-circuit current coefficient, is also known as the closing-capacity coefficient, since I_p is called the closing capacity. Thus, in each case, the asymmetrical coefficients can be derived from the symmetrical values and the circuit power factor. These coefficients are shown Fig. 9.4.

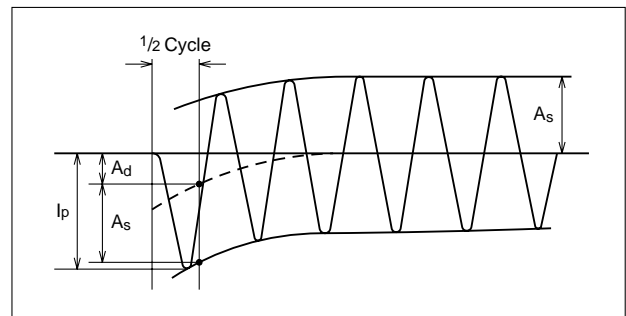

Fig. 9.3 Short-Circuit Current

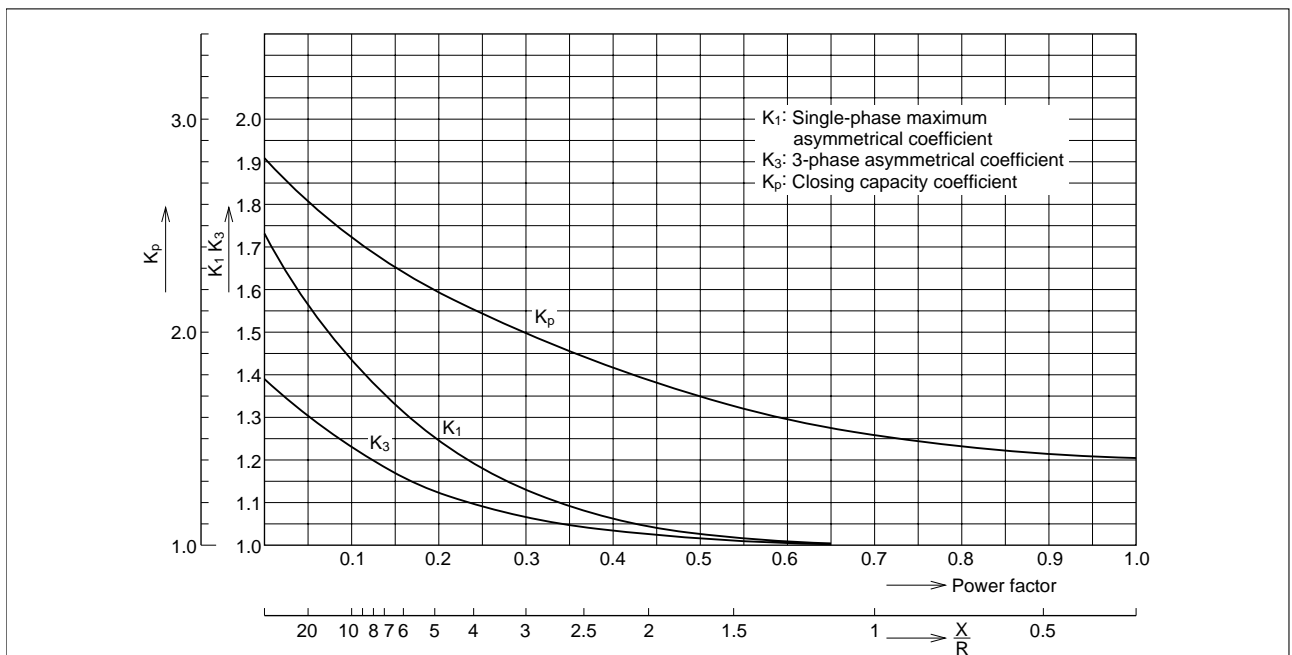

Fig. 9.4 Short-Circuit Current Coefficients

9.5 Calculation Procedures

Table 9.5 Necessary Equations

	Ohmic method	% impedance method	Remarks
3-phase	$I_s = \frac{V}{M3 \cdot Z} \dots\dots\dots\text{Eq. 1}$	$I_s = \frac{P}{M3 \cdot V \cdot \%Z} \times 100 \dots\dots\dots\text{Eq. 2}$ $= \frac{I_B}{\%Z} \times 100 \dots\dots\dots\text{Eq. 3}$	$\%Z = \frac{I_B \cdot Z}{V/M3} \times 100 \dots\dots\dots\text{Eq. 1'}$ $P = M3 \cdot V \cdot I_B \dots\dots\dots\text{Eq. 2'}$ <ul style="list-style-type: none"> Eq. 2 is derived from Eqs. 1, 1' and 2'. Eq. 3 is derived from Eqs. 1 and 1'. Because Eq. 1 can be obtained from Eqs. 2 and 12, it can be seen that I_s of the % impedance method is not affected by the selection of the reference capacity. The single-phase short-circuit current in a 3-phase circuit is $M3/2$ times the 3-phase short-circuit current. Consequently, a 3-phase circuit can be examined via the 3-phase short-circuit current.
	$I_{as} = K_3 \cdot I_s \dots\dots\dots\text{Eq. 4}$		
	<p>Key</p> <ul style="list-style-type: none"> I_s : 3-phase short-circuit current (A, sym) V : Line-line voltage (V) Z : Circuit impedance (1-phase component) I_{as} : 3-phase short-circuit current (A, asym.) P : Reference capacity (3-phase component, VA) $\%Z$: % impedance of circuit (single-phase component, %) I_B : Reference current (A) K_3 : 3-phase asymmetrical coefficient $K_3 = \frac{1}{3} \left\{ \sqrt{1 + 2e^{-\frac{2\pi R}{x}}} + 2\sqrt{1 + \frac{1}{2}e^{-\frac{2\pi R}{x}}} \right\}$		
Impedance	<ul style="list-style-type: none"> Conversion from percentage value to ohmic value $Z = \frac{V^2}{P} \cdot \%Z \times 10^{-2}\Omega \dots\dots\dots\text{Eq. 9}$ <p>Where P is the capacity at which %Z was derived.</p> <ul style="list-style-type: none"> Power supply impedance seen from primary side $Z = \frac{(\text{primary voltages})^2}{\text{short-circuit capacity}} \dots\dots\dots\text{Eq. 10}$ <ul style="list-style-type: none"> Supply impedance seen from secondary side $Z = \text{power supply impedance} \times \left(\frac{\text{secondary voltages}}{\text{primary voltage}} \right)^2 \dots\dots\dots\text{Eq. 11}$	<ul style="list-style-type: none"> Conversion from ohmic value to percentage value $\%Z = \frac{P}{V^2} \cdot Z \times 100\% \dots\dots\dots\text{Eq. 12}$ <ul style="list-style-type: none"> Conversion to %Z at reference capacity <p>Power-supply impedance:</p> $\%Z = \frac{\text{reference capacity}}{\text{short-circuit capacity}} \times 100 \dots\dots\dots\text{Eq. 13}$ <p>Transformer impedance, motor impedance:</p> $\%Z = \frac{\text{reference capacity}}{\text{equipment capacity}} \times \%Z \text{ at equipment capacity} \dots\dots\dots\text{Eq. 14}$	<ul style="list-style-type: none"> Eqs. 9 and 12 are derived from Eqs. 1' and 2', and Eqs. 3' and 4'. As the supply impedance is defined as 100% at short circuit capacity, for Eq. 13 conversion to reference capacity is made. When the supply short-circuit capacity is unknown, the impedance is taken as 0.0040+j0.0999 (%) for 3-phase supply, and 0.0080+j0.1998 (%) for a 1-phase supply (see Table 9.6). The motor and transformer impedances are converted from %Z at their equipment capacities into %Z at reference capacity, using Eq. 14. Eq. 14 for motor impedance becomes $(4.11 + j24.66) \times \frac{\text{reference capacity}}{\text{equipment capacity}}$ (For details see Table 9.6.)

9.5.1 Computation Methods

Regardless of method, the aim is to obtain the total impedance to the short-circuit point. One of two common methods is used, depending upon whether a percentage or ohmic value is required.

1. Percentage Impedance Method

This method is convenient in that the total can be derived by simply adding the individual impedances, without the necessity of conversion when a voltage transformer is used.

Since impedance is not an absolute value, being based on reference capacity, the reference value must first be determined. The reference capacity is normally taken as 1000kVA; thus, the percentage impedance at the transformer capacity, the percentage impedance derived from the power supply short-circuit capacity, and also the motor impedance must be converted into values based on 1000kVA (Eqs. 13 and 14). Also, the wiring and bus-duct impedances that are given in ohmic values must be converted into percentage impedances (Eq. 12).

2. Ohmic Method

In calculating short-circuit currents for a number of points in a system, since the wire and bus-duct im-

pedances will be different in each case, it is convenient to use Ohm's law, in that if, for example, the total supply impedance (Z_s) is derived as an ohmic value, the total impedance up to the short-circuit point can be obtained by simply adding this value to the wire and bus-duct impedances, which are in series with the supply. For total 3-phase supply impedance (Z_s), refer to Table 9.4 (which shows calculations of Z_s based on standard transformers) to eliminate troublesome calculations attendant to the motor impedance being in parallel with Z_s .

9.5.2 Calculation Examples

1. 3-phase Circuit

For the short circuit at point S in Fig. 9.5, the equivalent circuit will be as shown in Fig. 9.6. The 3-phase short-circuit current can be obtained by either the %-impedance method or Ohm's law, as given in Table 9.6.

Table 9.6 Calculation Example: 3-Phase Short-Circuit Current

	% impedance method	Ohmic method
Power supply impedance Z_L	<p>The supply short-circuit capacity, being unknown, is defined as 1000MVA with $X_L/R_L = 25$. From Eq. 13, at the 1000kVA reference capacity:</p> $Z_L = \frac{1000 \times 10^3}{1000 \times 10^6} \times 100 = 0.1 \text{ (\%)}$ <p>since $X_L/R_L = 25$,</p> $0.1 = \sqrt{R_L^2 + (25R_L)^2} = 25.02R_L$ $Z_L = R_L + jX_L = 0.0040 + j0.0999 \text{ (\%)}$	<p>The supply short-circuit capacity, being unknown, is defined as 1000MVA with $X_L/R_L = 25$. From Eq. 10, the supply impedance seen from the primary side:</p> $Z_L = \frac{(6600)^2}{1000 \times 10^6} = 0.0436 \text{ (\Omega)}$ <p>and since $X_L/R_L = 25$: $Z_L = 1.741 + j43.525 \text{ (m}\Omega\text{)}$ From Eq. 11, supply impedance converted to the secondary side is:</p> $Z_L = (1.741 + j43.525) \times \left(\frac{440}{6600}\right)^2$ $= 0.00773 + j0.1934 \text{ (m}\Omega\text{)}$ <p>Note: The supply ohmic impedance can more simply be derived: since it is 100% at short-circuit capacity, Z_L is obtained from Eq. 9, after percentage to ohmic conversion:</p> $Z_L = \frac{440^2}{1000 \times 10^6} \times 100 \times 10^{-2} \times 10^3 = 0.1936 \text{ (m}\Omega\text{)}$ <p>and since $X_L/R_L = 25$, $Z_L = 0.0069 + j0.1721 \text{ (m}\Omega\text{)}$</p>
Transformer impedance Z_T	<p>From Table 9.1: $Z_T = 1.23 + j5.41$ From Eq. 14, after conversion to reference capacity, 1000kVA:</p> $Z_T = (1.23 + j5.41) \times \frac{1000 \times 10^3}{1500 \times 10^3}$ $= 0.82 + j3.607 \text{ (\%)}$	<p>From Table 9.1: $Z_T = 1.23 + j5.41 \text{ (\%)}$ From Eq. 9, after percentage to ohmic conversion.</p> $Z_T = \frac{440^2}{1500 \times 10^3} \times (1.23 + j5.41) \times 10^{-2} \text{ (\Omega)}$ $= 1.2906 + j6.9825 \text{ (m}\Omega\text{)}$
Motor impedance Z_M	<p>The total motor capacity, being unknown, is assumed equal to the transformer capacity, with: $\%Z_M = 25(\%)$ $X_M/R_M = 6$ From Eq. 14, at reference capacity, 1000kVA:</p> $Z_M = (4.11 + j24.66) \times \frac{1000 \times 10^3}{1500 \times 10^3 \times 0.8}$ $= 3.42 + j20.55 \text{ (\%)}$	<p>The total motor capacity, being unknown, is assumed equal to the transformer capacity, with: $\%Z_M = 25(\%)$ $X_M/R_M = 6$ $Z_M = 4.11 + j24.66$ $Z_M = 4.11 + j24.66 \text{ (\%)}$ From Eq. 9, after percentage to ohmic conversion:</p> $Z_M = \frac{440^2}{1500 \times 10^3 \times 0.8} \times (4.11 + j24.66) \times 10^{-2} \text{ (\Omega)}$ $= 6.6294 + j39.7847 \text{ (m}\Omega\text{)}$
Total power supply impedance Z_S	$Z_S = \frac{(Z_L + Z_T)Z_M}{Z_L + Z_T + Z_M}$ $= 0.671 + j3.142 \text{ (\%)}$ <p>(R and X are calculated, per §9.3.2.)</p>	$Z_S = \frac{(Z_L + Z_T)Z_M}{Z_L + Z_T + Z_M}$ $= 1.299 + j6.083 \text{ (m}\Omega\text{)}$ <p>(R and X are calculated, per §9.3.2.)</p>
Line impedance Z_W	<p>Multiplying the value from Table 9.2 by a wire length of 10M, and converting to the 1000kVA reference, from Eq. 12:</p> $Z_W = \frac{1000 \times 10^3}{440^2} (0.0601 + j0.079) \times 10^{-3} \times 10 \times 100$ $= 0.310 + j0.408 \text{ (\%)}$	<p>Multiplying the value from Table 9.2 by a wire length of 10M.</p> $Z_W = (0.0601 + j0.079) \times 10$ $= 0.601 + j0.79 \text{ (m}\Omega\text{)}$
Total impedance Z	$Z = Z_S + Z_W$ $= 0.981 + j3.550 = 3.683 \text{ (\%)}$	$Z = Z_S + Z_W$ $= 1.900 + j6.873 = 7.1307 \text{ (m}\Omega\text{)}$
3-phase short-circuit symmetrical current I_s	<p>From Eq. 2:</p> $I_s = \frac{1000 \times 10^3}{\sqrt{3} \times 440 \times 3.683} \times 100$ $= 35.622 \text{ (A)}$	<p>From Eq. 1</p> $I_s = \frac{440}{\sqrt{3} \times 7.1307 \times 10^{-3}}$ $= 35.622 \text{ (A)}$

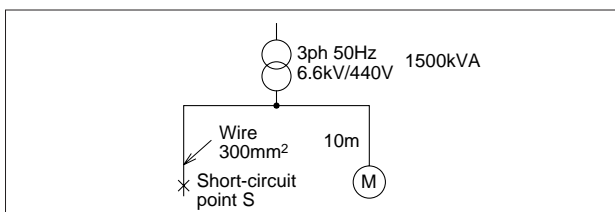

Fig. 9.5 Circuit Configuration

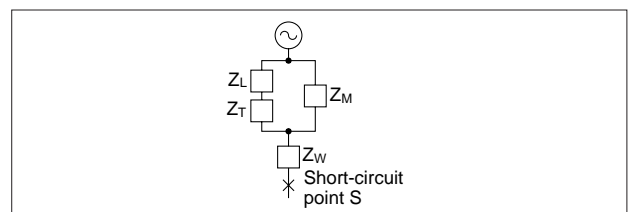

Fig. 9.6 Equivalent Circuit

MOULDED CASE CIRCUIT BREAKERS

www.DataSheet4U.com

Safety Tips : Be sure to read the instruction manual fully before using this product.

 **mitsubishi electric corporation**
HEAD OFFICE: MITSUBISHI DENKI BLDG., MARUNOUCHI, TOKYO 100-8310. TELEX: J24532 CABLE: MELCO TOKYO