

N-Channel Enhancement Mode Power MOSFET

MTN5N50BJ3

BV_{DSS}	500V
$I_D @ V_{GS}=10V, T_C=25^\circ C$	4.5A
$R_{DSON(TYP)} @ V_{GS}=10V, I_D=2.25A$	1.1 Ω

Features

- Low On Resistance
- Simple Drive Requirement
- Low Gate Charge
- Fast Switching Characteristic
- RoHS compliant package
- Pb-free lead plating and halogen-free package

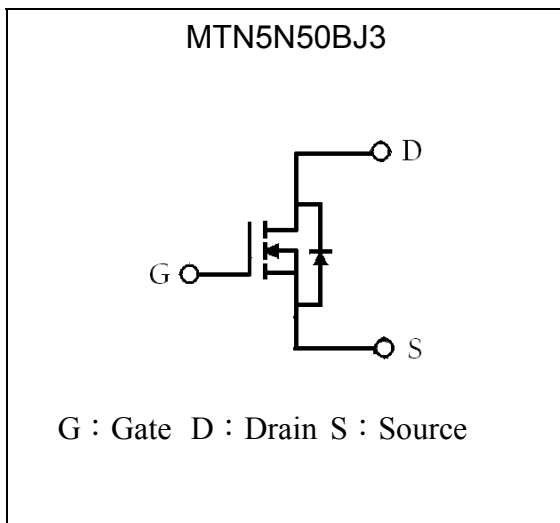
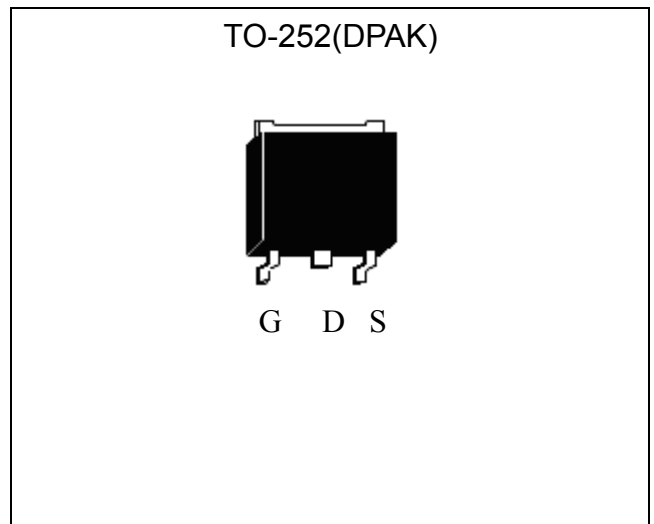
Symbol

Outline

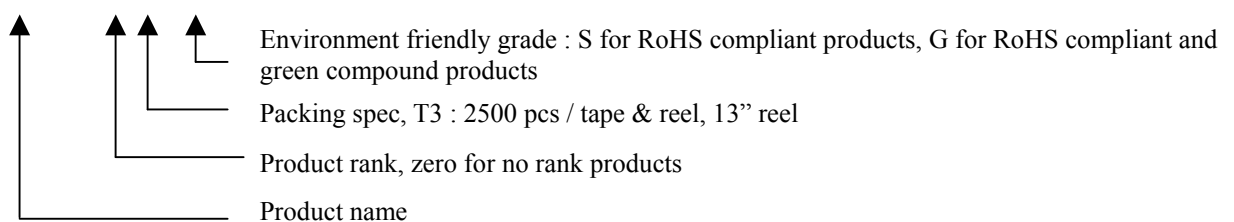
Ordering Information

Device	Package	Shipping
MTN5N50BJ3-0-T3-G	TO-252 (Pb-free lead plating and halogen-free package)	2500 pcs / Tape & Reel





Absolute Maximum Ratings (T_C=25°C)

Parameter	Symbol	Limits	Unit
Drain-Source Voltage	V _{DS}	500	V
Gate-Source Voltage	V _{GS}	±30	
Continuous Drain Current @T _C =25°C, V _{GS} =10V	I _D	4.5	A
Continuous Drain Current @T _C =100°C, V _{GS} =10V		2.8	
Pulsed Drain Current (Note 1)	I _{DM}	18	
Single Pulse Avalanche Energy (Note 2)	E _{AS}	90	mJ
Avalanche Current (Note 1)	I _{AS}	4.5	A
Repetitive Avalanche Energy (Note 1)	E _{AR}	4.8	mJ
Maximum Temperature for Soldering @ Lead at 0.125 in(0.318mm) from case for 10 seconds	T _L	300	°C
Total Power Dissipation (T _A =25°C) (Note 4)	P _D	2	W
Total Power Dissipation (T _C =25°C)		48	W
Linear Derating Factor		0.38	W/°C
Operating Junction and Storage Temperature	T _j , T _{stg}	-55~+150	°C

Thermal Data

Parameter	Symbol	Value	Unit
Thermal Resistance, Junction-to-case, max	R _{th,j-c}	2.6	°C/W
Thermal Resistance, Junction-to-ambient, max (Note 4)	R _{th,j-a}	50	
Thermal Resistance, Junction-to-ambient, max		110	

Note : 1.Repetitive rating; pulse width limited by maximum junction temperature.

2. I_{AS}=4.5A, V_{DD}=50V, L=8mH, R_G=25Ω, starting T_J=+25°C.

3. I_{SD}≤4.5A, dI/dt≤100A/μs, V_{DD}≤BV_{DSS}, starting T_J=+25°C.

4. When the device is mounted on 1 in² FR-4 board with 2 oz. copper, in a still air environment with T_A=25°C.

Characteristics (T_C=25°C, unless otherwise specified)

Symbol	Min.	Typ.	Max.	Unit	Test Conditions
Static					
BV _{DSS}	500	-	-	V	V _{GS} =0V, I _D =250μA, T _J =25°C
ΔBV _{DSS} /ΔT _J	-	0.6	-	V/°C	Reference to 25°C, I _D =250μA
V _{GS(th)}	2.0	-	4.0	V	V _{DS} = V _{GS} , I _D =250μA
*G _{FS}	-	5	-	S	V _{DS} =15V, I _D =2.25A
I _{GSS}	-	-	±100	nA	V _{GS} =±30V
I _{DSS}	-	-	1	μA	V _{DS} =500V, V _{GS} =0V
	-	-	10		V _{DS} =400V, V _{GS} =0V, T _C =125°C
*R _{DS(ON)}	-	1.1	1.5	Ω	V _{GS} =10V, I _D =2.25A
Dynamic					
*Q _g	-	17.4	-	nC	I _D =4.5A, V _{DD} =400V, V _{GS} =10V
*Q _{gs}	-	3.4	-		
*Q _{gd}	-	7.6	-		

*td(ON)	-	10.6	-	ns	V _{DD} =250V, I _D =4.5A, V _{GS} =10V, R _G =25Ω
*tr	-	10	-		
*td(OFF)	-	35	-		
*tr	-	31.2	-		
C _{iss}	-	572	-	pF	V _{GS} =0V, V _{DS} =25V, f=1MHz
C _{oss}	-	65	-		
C _{rss}	-	32	-		
Source-Drain Diode					
*I _S	-	-	4.5	A	
*I _{SM}	-	-	18		
*V _{SD}	-	-	1.5	V	I _S =4.5A, V _{GS} =0V
*trr	-	260	-	ns	V _{GS} =0, I _F =4.5A, dI _F /dt=100A/μs
*Q _{rr}	-	1.1	-	μC	

*Pulse Test : Pulse Width ≤300μs, Duty Cycle≤2%

Recommended soldering footprint

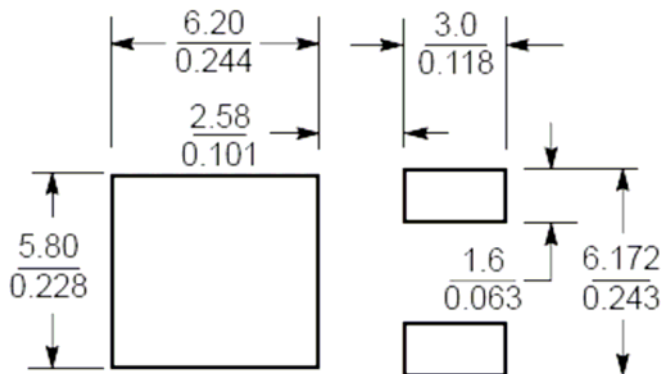

Unit ($\frac{\text{mm}}{\text{inch}}$)

Typical Characteristics

Typical Output Characteristics

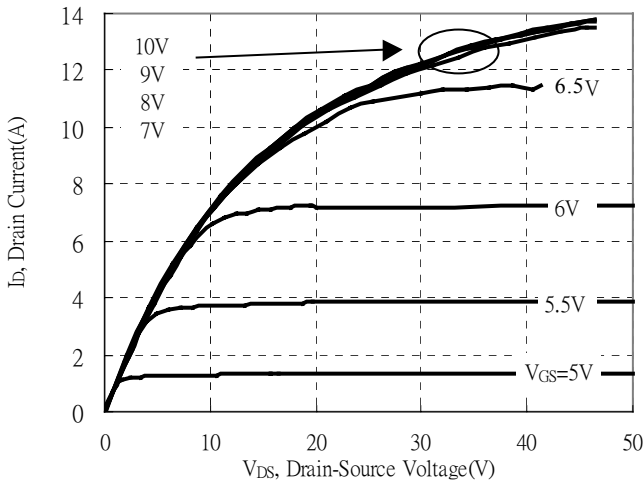

Brekdown Voltage vs Ambient Temperature

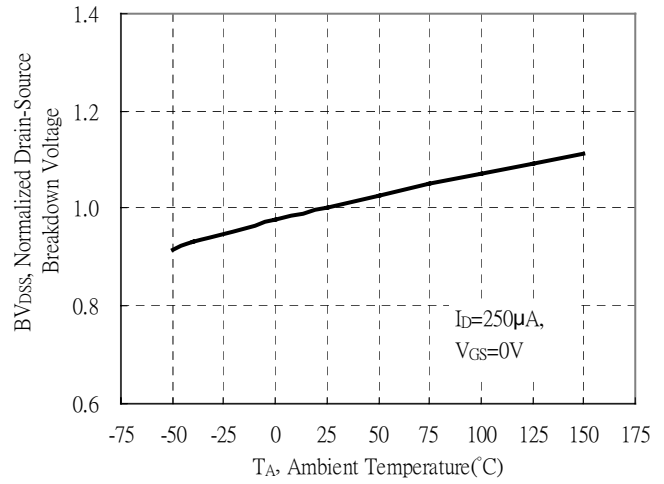

Static Drain-Source On-State resistance vs Drain Current

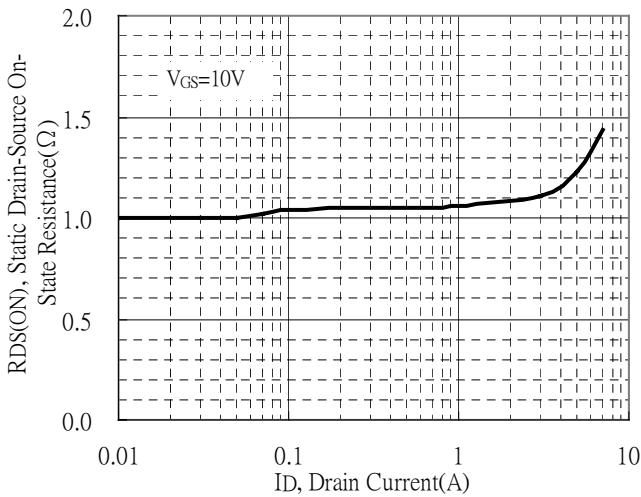

Static Drain-Source On-resistance vs Ambient Temperature

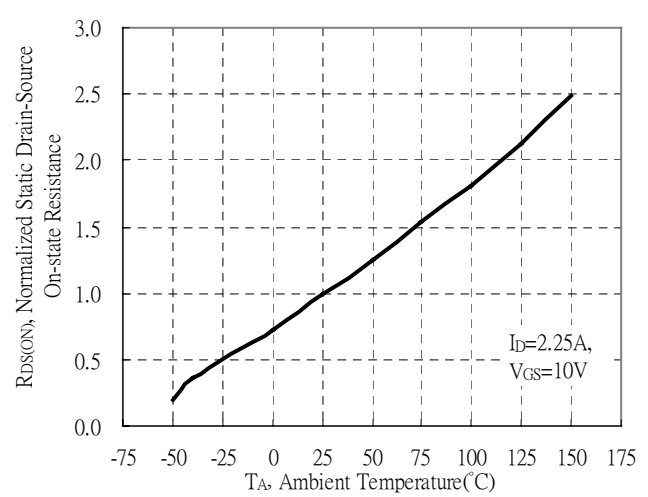

Static Drain-Source On-State Resistance vs Gate-Source Voltage

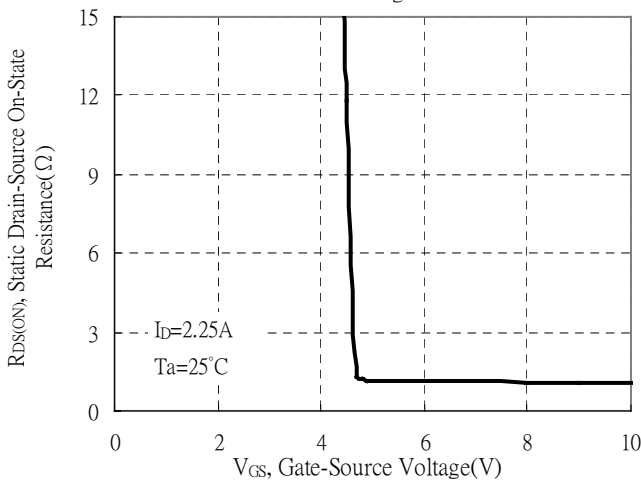

Forward Drain Current vs Source-Drain Voltage

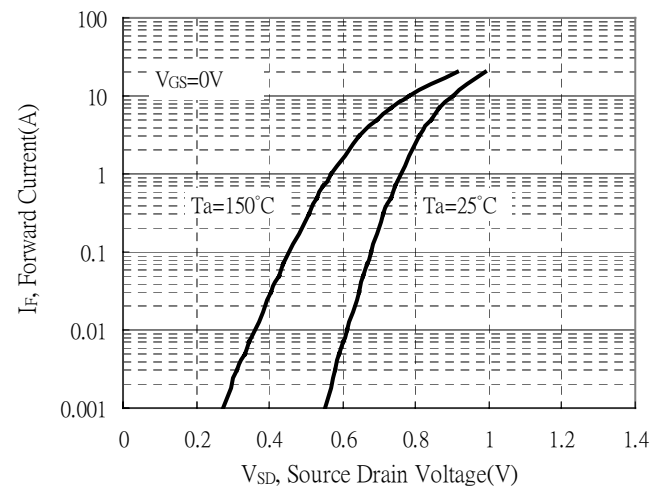

Typical Characteristics(Cont.)

Capacitance vs Reverse Voltage

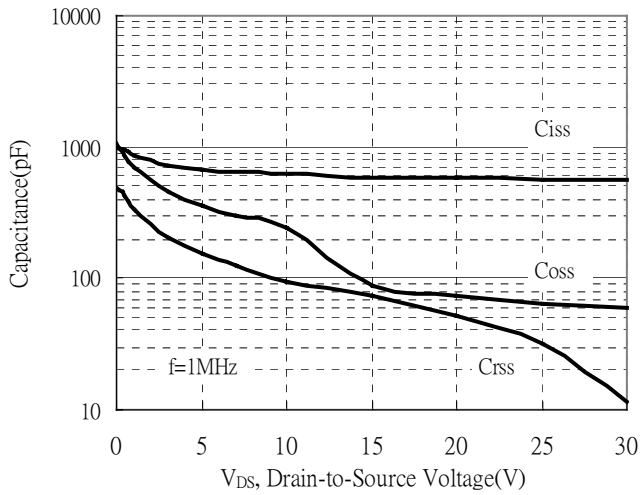

Threshold Voltage vs Junction Temperature

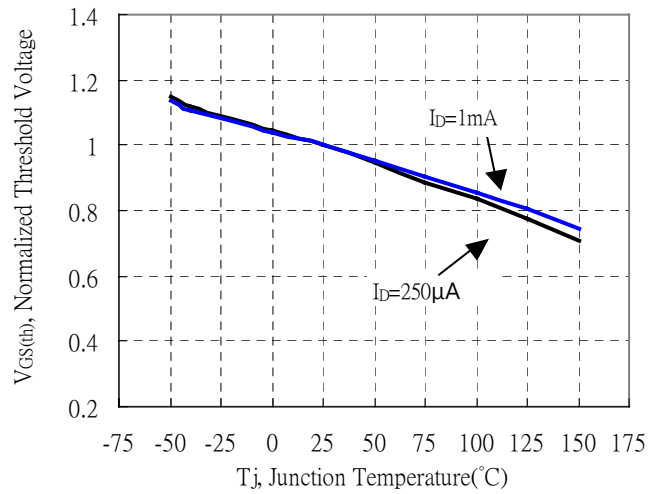

Forward Transfer Admittance vs Drain Current

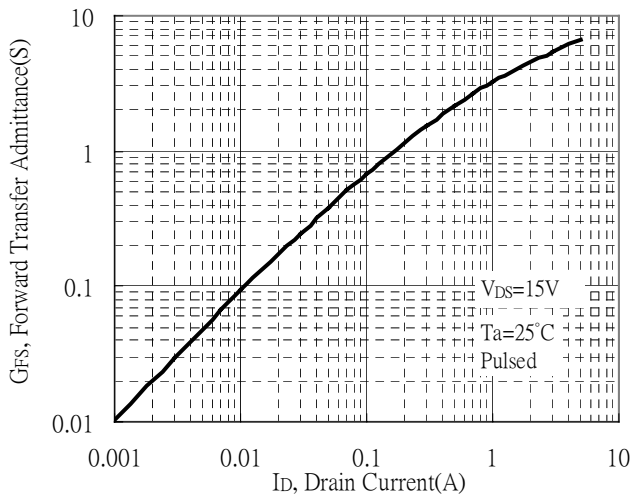

Gate Charge Characteristics

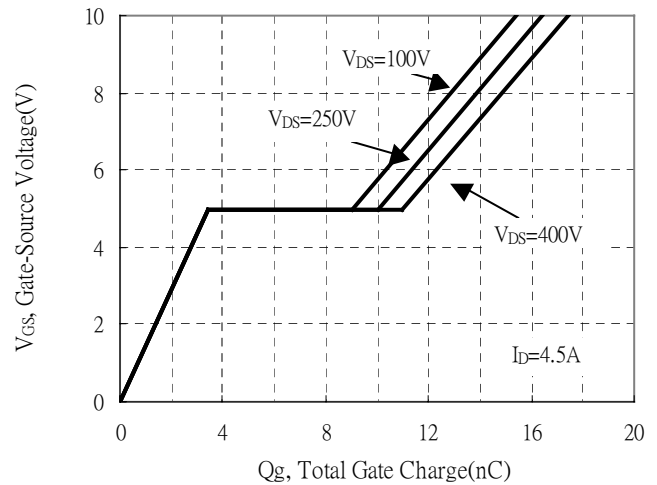

Maximum Safe Operating Area

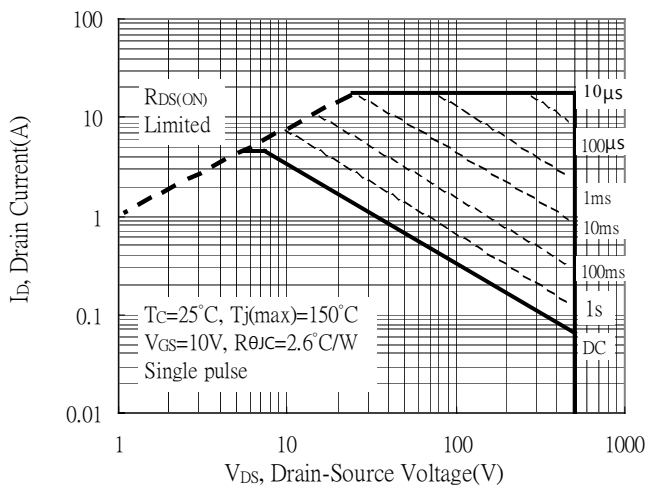

Maximum Drain Current vs Case Temperature

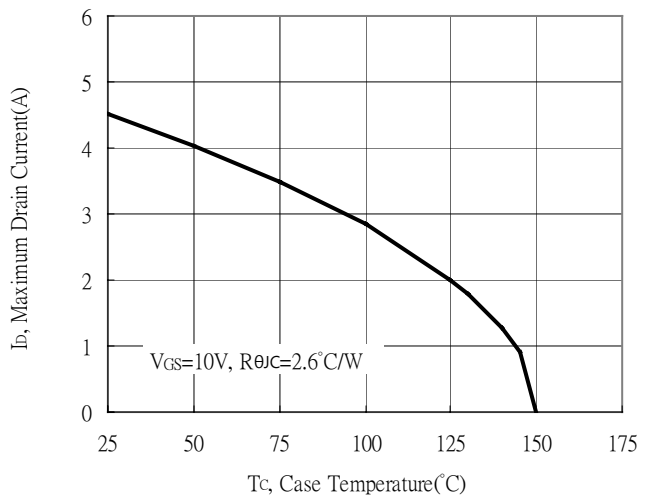

Typical Characteristics(Cont.)

Drain Current vs Gate-Source Voltage

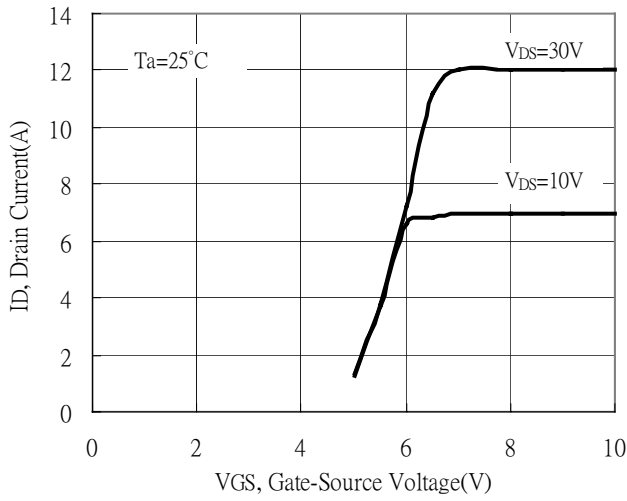

Single Pulse Power Rating, Junction to Case

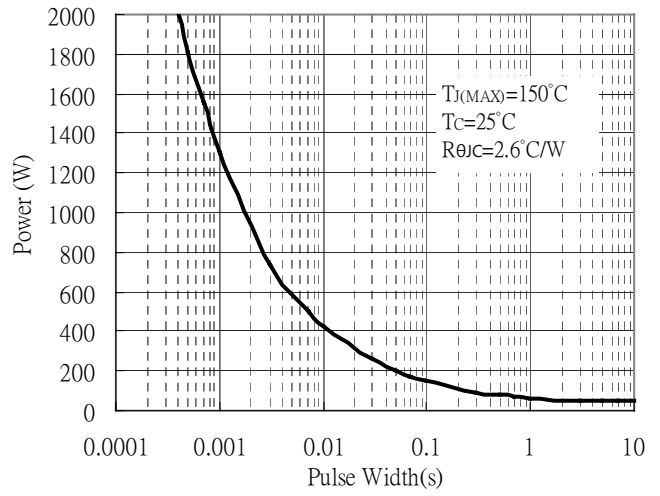

Transient Thermal Response Curves

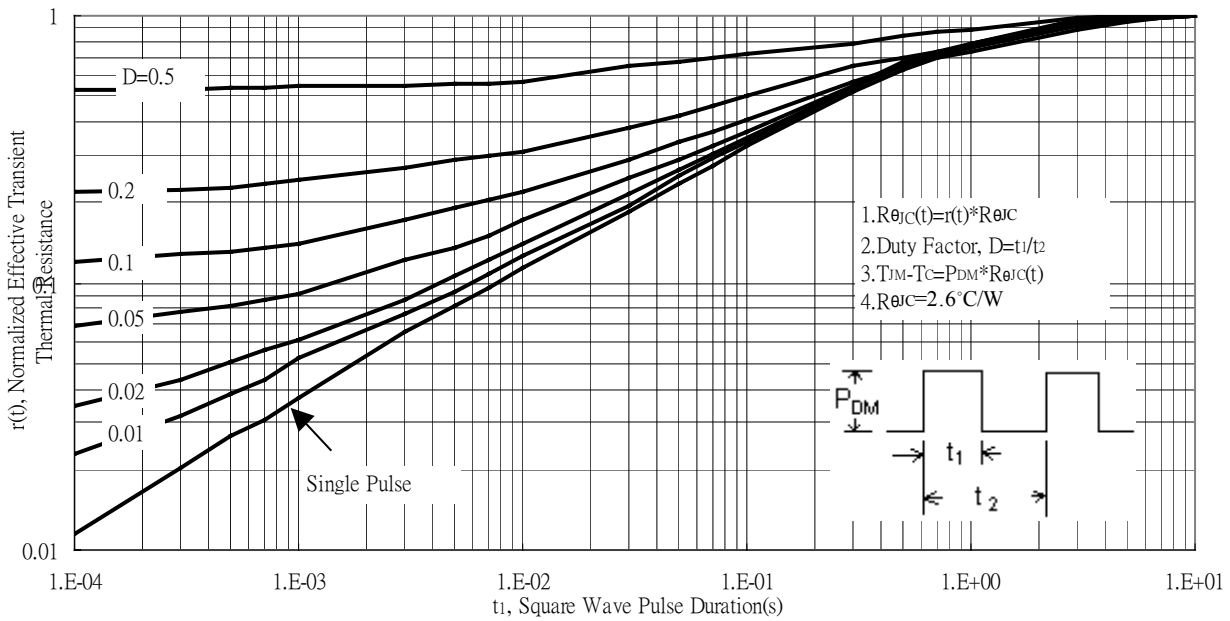

Test Circuit and Waveforms

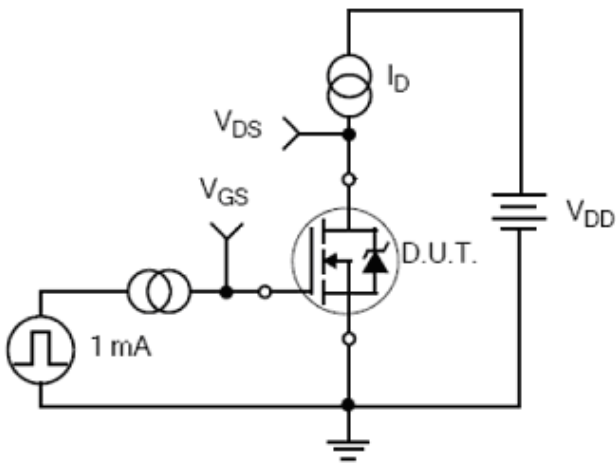

Gate Charge Test Circuit

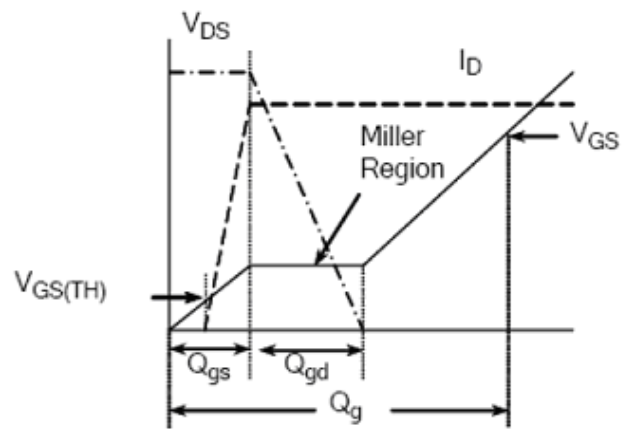

Gate Charge Waveform

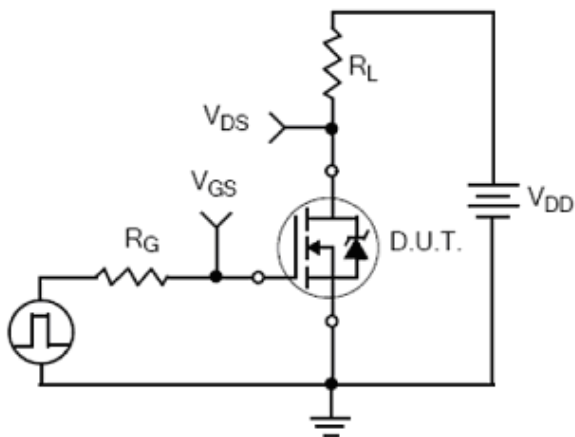

Resistive Switching Test Circuit

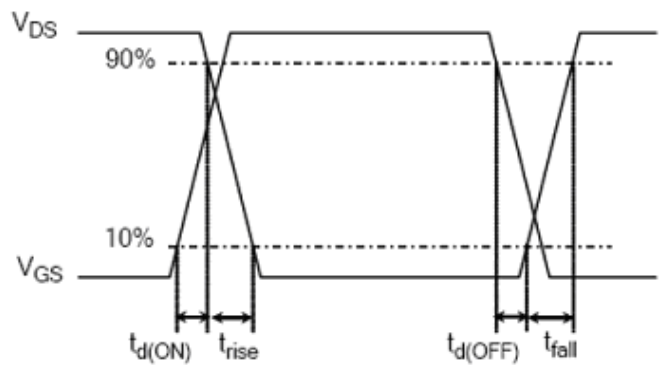

Resistive Switching Waveforms

Test Circuit and Waveforms(Cont.)

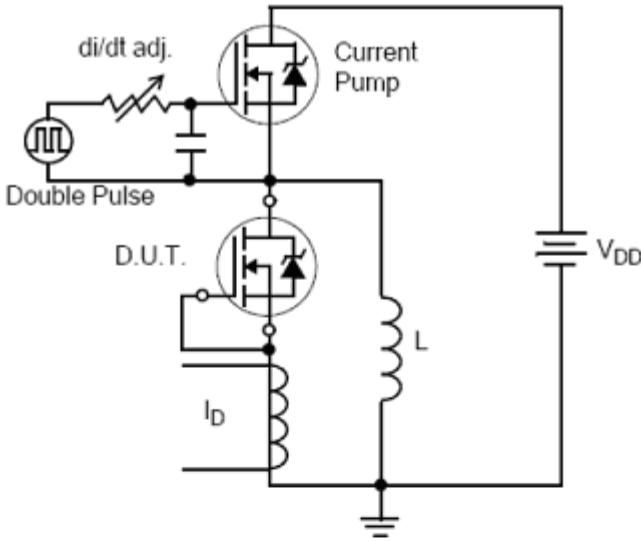

Diode Reverse Recovery Test Circuit

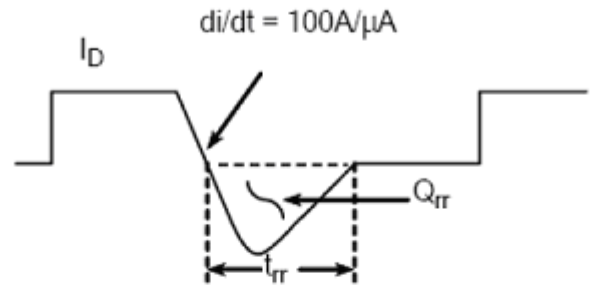

Diode Reverse Recovery Waveform

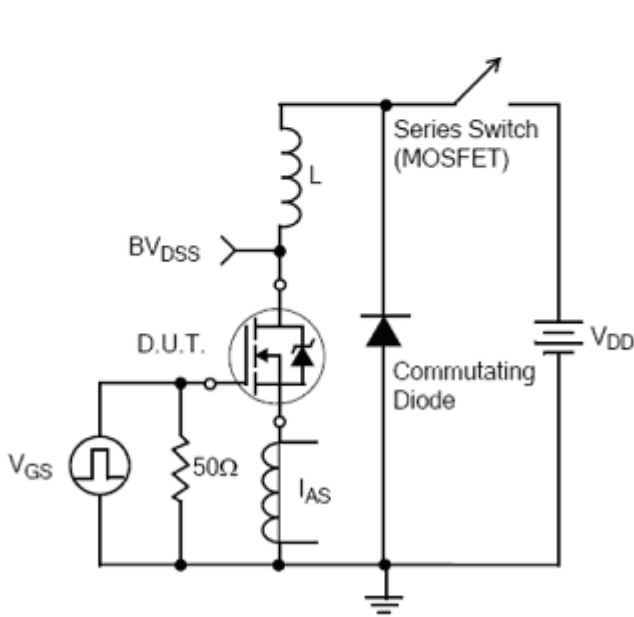

Unclamped Inductive Switching Test Circuit

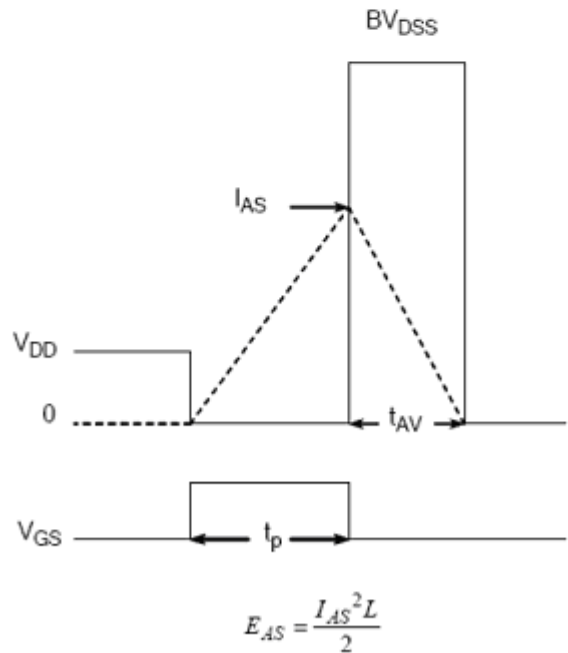

Unclamped Inductive Switching Waveforms

Recommended wave soldering condition

Product	Peak Temperature	Soldering Time
Pb-free devices	260 +0/-5 °C	5 +1/-1 seconds

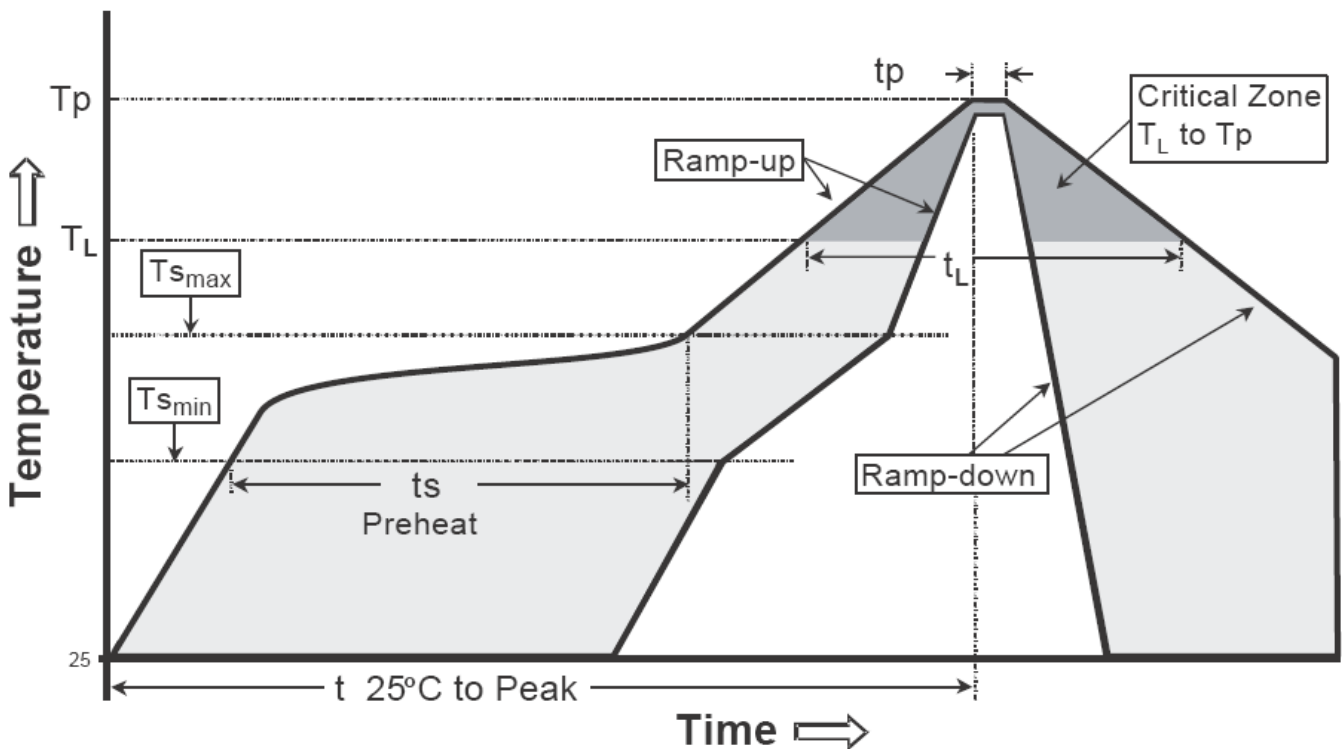
Recommended temperature profile for IR reflow

Profile feature	Sn-Pb eutectic Assembly	Pb-free Assembly
Average ramp-up rate (Tsmax to Tp)	3°C/second max.	3°C/second max.
Preheat		
-Temperature Min(Ts min)	100°C	150°C
-Temperature Max(Ts max)	150°C	200°C
-Time(ts min to ts max)	60-120 seconds	60-180 seconds
Time maintained above:		
-Temperature (Tl)	183°C	217°C
- Time (tl)	60-150 seconds	60-150 seconds
Peak Temperature(Tp)	240 +0/-5 °C	260 +0/-5 °C
Time within 5°C of actual peak temperature(tp)	10-30 seconds	20-40 seconds
Ramp down rate	6°C/second max.	6°C/second max.
Time 25 °C to peak temperature	6 minutes max.	8 minutes max.

Note : All temperatures refer to topside of the package, measured on the package body surface.

TO-252 Dimension

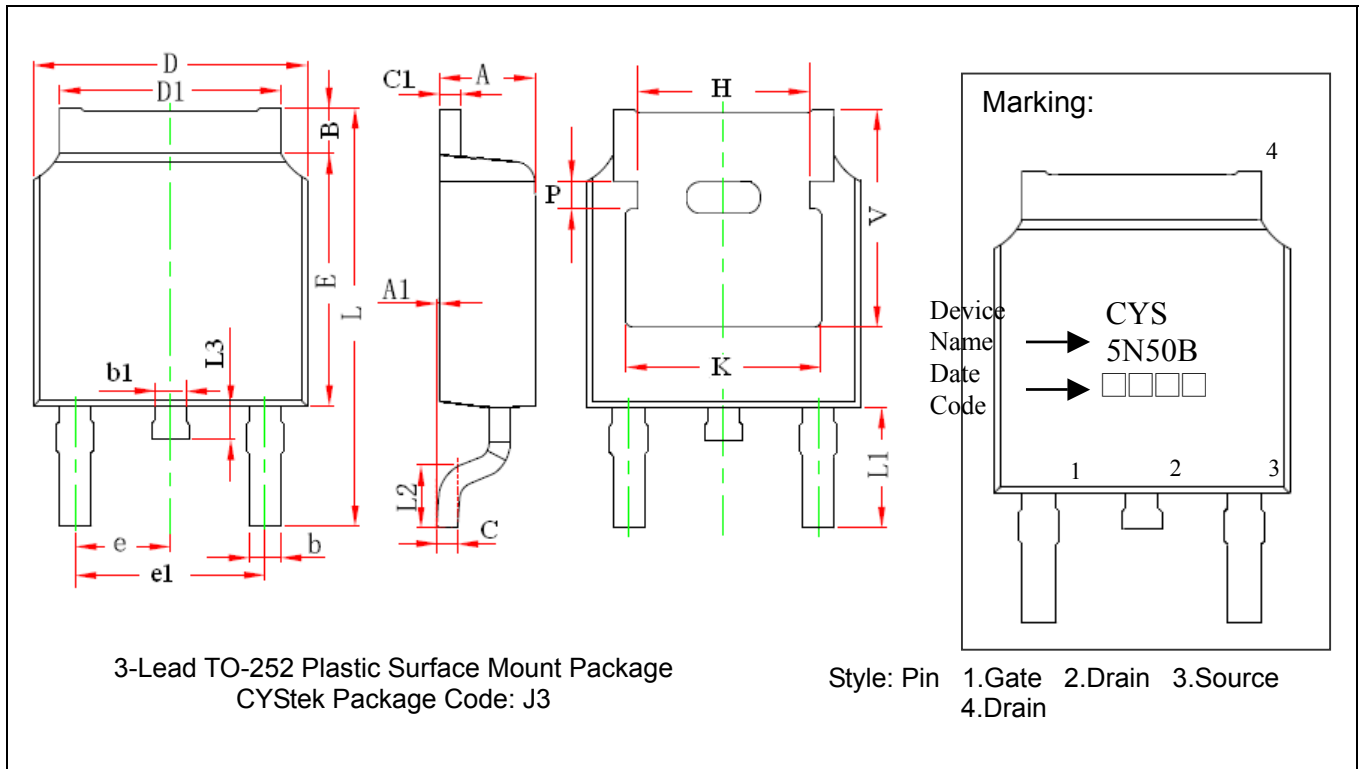

DIM	Inches		Millimeters		DIM	Inches		Millimeters	
	Min.	Max.	Min.	Max.		Min.	Max.	Min.	Max.
A	0.087	0.094	2.200	2.400	e	0.086	0.094	2.186	2.386
A1	0.000	0.005	0.000	0.127	e1	0.172	0.188	4.372	4.772
B	0.039	0.048	0.990	1.210	H	0.163	REF	4.140	REF
b	0.026	0.034	0.660	0.860	K	0.190	REF	4.830	REF
b1	0.026	0.034	0.660	0.860	L	0.386	0.409	9.800	10.400
C	0.018	0.023	0.460	0.580	L1	0.114	REF	2.900	REF
C1	0.018	0.023	0.460	0.580	L2	0.055	0.067	1.400	1.700
D	0.256	0.264	6.500	6.700	L3	0.024	0.039	0.600	1.000
D1	0.201	0.215	5.100	5.460	P	0.026	REF	0.650	REF
E	0.236	0.244	6.000	6.200	V	0.211	REF	5.350	REF

Notes: 1.Controlling dimension: millimeters.
 2.Maximum lead thickness includes lead finish thickness, and minimum lead thickness is the minimum thickness of base material.
 3.If there is any question with packing specification or packing method, please contact your local CYStek sales office.

Material:

- Lead : Pure tin plated.
- Mold Compound: Epoxy resin family, flammability solid burning class: UL94V-0.

Important Notice:

- All rights are reserved. Reproduction in whole or in part is prohibited without the prior written approval of CYStek.
- CYStek reserves the right to make changes to its products without notice.
- CYStek **semiconductor products are not warranted to be suitable for use in Life-Support Applications, or systems.**
- CYStek assumes no liability for any consequence of customer product design, infringement of patents, or application assistance.