

**MSK**

M. S. KENNEDY CORP.

**FET INPUT  
DIFFERENTIAL OP-AMP****032**

4707 Dey Road Liverpool, N.Y. 13088

(315) 701-6751

**MIL-PRF-38534 CERTIFIED****FEATURES:**

- Fast Slew Rate
- Fast Settling Time
- FET Input
- Wide Bandwidth
- Electrically Isolated
- LH0032 Pin Compatible Upgrade

**DESCRIPTION:**

The MSK 032 is a high speed, FET input, differential operational amplifier. Intended to replace the popular LH0032, the MSK 032 offers improved performance, much greater consistency from lot to lot, and improved stability over its operating temperature range.

The MSK 032's wide bandwidth, accuracy and output drive capability make it a superior choice for applications such as video amplifiers, buffer amplifiers, comparator circuits and other high frequency signal transfer circuits. As with all MSK products, the MSK 032 is conservatively specified and is available in military and industrial grades.

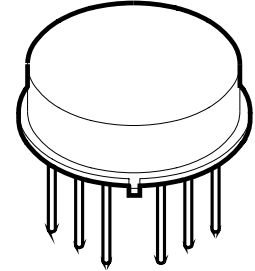
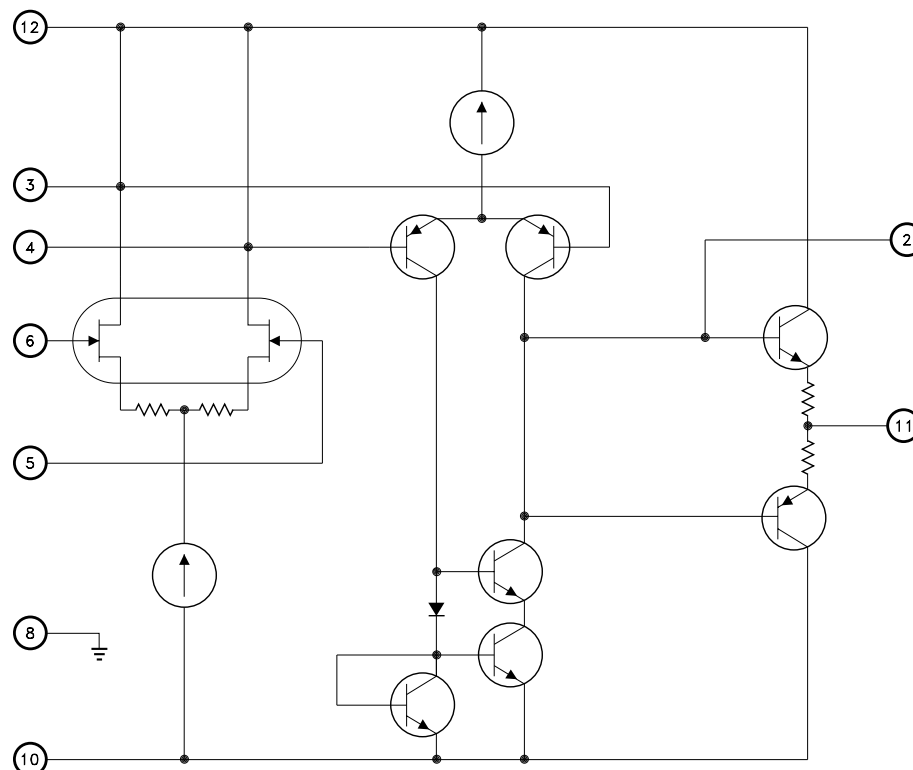
**EQUIVALENT SCHEMATIC****TYPICAL APPLICATIONS**

- Video Amplifiers
- Buffer Amplifiers
- Comparator Circuits

**PIN-OUT INFORMATION**

|   |                      |    |                       |
|---|----------------------|----|-----------------------|
| 1 | NC                   | 7  | NC                    |
| 2 | Output Compensation  | 8  | Case Connection       |
| 3 | Compensation/Balance | 9  | NC                    |
| 4 | Compensation/Balance | 10 | Negative Power Supply |
| 5 | Inverting Input      | 11 | Output                |
| 6 | Non-Inverting Input  | 12 | Positive Power Supply |

## ABSOLUTE MAXIMUM RATINGS

|              |  |  |          |                                |                                   |
|--------------|--|--|----------|--------------------------------|-----------------------------------|
| $\pm V_{CC}$ | Supply Voltage . . . . .                                   | $\pm 18V$  | $T_{ST}$ | Storage Temperature Range      | $-65^{\circ}C$ to $+150^{\circ}C$ |
| $I_{OUT}$    | Output Current . . . . .                                   | $\pm 40mA$   | $T_{LD}$ | Lead Temperature Range         | $300^{\circ}C$<br>(10 Seconds)    |
| $V_{IN}$     | Differential Input Voltage . . . . .                       | $\pm 30V$  | $T_J$    | Junction Temperature . . . . . | $175^{\circ}C$                    |
| $T_C$        | Case Operating Temperature Range<br>(MSK 032B/E) . . . . . | $-55^{\circ}C$ to $+125^{\circ}C$<br>(MSK 032) . . . . . |          |                                |                                   |
| $R_{TH}$     | Thermal Resistance . . . . .                               | $187^{\circ}C/W$<br>(Output Switches) (Junction to Case) |          |                                |                                   |

## ELECTRICAL SPECIFICATIONS

$\pm V_{CC} = \pm 15VDC$  Unless Otherwise Specified

| Parameter                       | Test Conditions                            | Group A<br>Subgroup | MSK 032B/E     |           |           | MSK 032        |           |           | Units             |
|---------------------------------|--|---------------------|----------------|-----------|-----------|----------------|-----------|-----------|-------------------|
|                                 |  |                     | Min.           | Typ.      | Max.      | Min.           | Typ.      | Max.      |                   |
| <b>STATIC</b>                   |  |                     |                |           |           |                |           |           |                   |
| Supply Voltage Range ② ⑦        |  | -                   | $\pm 10$       | $\pm 15$  | $\pm 18$  | $\pm 10$       | $\pm 15$  | $\pm 18$  | V                 |
| Quiescent Current               | $V_{IN} = 0V$                              | 1                   | -              | $\pm 15$  | $\pm 20$  | -              | $\pm 15$  | $\pm 22$  | mA                |
|                                 |  | 2,3                 | -              | $\pm 18$  | $\pm 25$  | -              | -         | -         | mA                |
| <b>INPUT</b>                    |  |                     |                |           |           |                |           |           |                   |
| Input Offset Voltage            | Bal.Pins = NC $V_{IN} = 0V$ $A_V = -10V/V$ | 1                   | -              | $\pm 0.5$ | $\pm 5$   | -              | $\pm 1$   | $\pm 7$   | mV                |
| Input Offset Voltage Drift      | Bal.Pins = NC $V_{IN} = 0V$                | 2,3                 | -              | $\pm 10$  | $\pm 25$  | -              | -         | -         | $\mu V/^{\circ}C$ |
| Input Offset Adjust             | $R_{POT} = 10K\Omega$ $T_O + V_{CC}$       | 1                   | Adjust to Zero |           |           | Adjust to Zero |           |           | mV                |
|                                 |  | 2,3                 | Adjust to Zero |           |           | -              | -         | -         | mV                |
| Input Bias Current              | $V_{CM} = 0V$                              | 1                   | -              | $\pm 50$  | $\pm 250$ | -              | $\pm 75$  | $\pm 300$ | pA                |
|                                 | Either Input                               | 2,3                 | -              | $\pm 0.2$ | $\pm 10$  | -              | -         | -         | nA                |
| Input Offset Current            | $V_{CM} = 0V$                              | 1                   | -              | 10        | 100       | -              | 20        | 150       | pA                |
|                                 |  | 2,3                 | -              | 0.1       | 5         | -              | -         | -         | nA                |
| Input Impedance ②               | $F = DC$                                   | -                   | -              | $10^{12}$ | -         | -              | $10^{12}$ | -         | $\Omega$          |
| Power Supply Rejection Ratio ②  | $\Delta V_{CC} = \pm 5V$                   | -                   | 60             | 70        | -         | 55             | 70        | -         | dB                |
| Common Mode Rejection Ratio ②   | $F = DC$ $V_{CM} = \pm 10V$                | -                   | 70             | 80        | -         | 65             | 80        | -         | dB                |
| Input Noise Voltage             | $F = 10Hz$ To $1KHz$                       | -                   | -              | 1.5       | -         | -              | 1.5       | -         | $\mu V_{rms}$     |
| Equivalent Input Noise          | $F = 1KHz$                                 | -                   | -              | 40        | -         | -              | 40        | -         | $nV\sqrt{Hz}$     |
| <b>OUTPUT</b>                   |  |                     |                |           |           |                |           |           |                   |
| Output Voltage Swing            | $F \leq 5MHz$ $R_L = 510\Omega$            | 4                   | $\pm 10$       | $\pm 12$  | -         | $\pm 10$       | $\pm 12$  | -         | V                 |
| Output Current                  | $R_L = 510\Omega$                          | 4                   | $\pm 20$       | $\pm 30$  | -         | $\pm 20$       | $\pm 30$  | -         | mA                |
| Settling Time to 1% ① ②         | $R_L = 1K\Omega$ $10V$ step                | 4                   | -              | 50        | 60        | -              | 55        | 65        | nS                |
| Settling Time to 0.1% ②         | $R_L = 1K\Omega$ $10V$ step                | 4                   | -              | 60        | 90        | -              | 70        | 100       | nS                |
| Full Power Bandwidth            | $R_L = 510\Omega$ $V_O = \pm 10V$          | 4                   | 8              | 9         | -         | 7              | 8         | -         | MHz               |
| Bandwidth (Small Signal) ②      | $R_L = 510\Omega$                          | 4                   | 80             | 90        | -         | 75             | 80        | -         | MHz               |
| <b>TRANSFER CHARACTERISTICS</b> |  |                     |                |           |           |                |           |           |                   |
| Slew Rate Limit                 | $V_{OUT} = \pm 10V$ $R_L = 510\Omega$      | 4                   | 500            | 600       | -         | 475            | 550       | -         | $V/\mu S$         |
| Open Loop Voltage Gain ②        | $V_{OUT} = \pm 10V$ $R_L = 1K\Omega$       | 4                   | 80             | 90        | -         | 75             | 85        | -         | dB                |

### NOTES:

- ①  $A_V = -1$ , measured in false summing junction circuit.
- ② Devices shall be capable of meeting the parameter, but need not be tested. Typical parameters are for reference only.
- ③ Industrial grade and "E" suffix devices shall be tested to subgroups 1 and 4 unless otherwise specified.
- ④ Military grade devices ('B' suffix) shall be 100% tested to subgroups 1,2,3 and 4.
- ⑤ Subgroup 5 and 6 testing available upon request.
- ⑥ Subgroup 1,4  $T_A = T_C = +25^{\circ}C$   
Subgroup 2,5  $T_A = T_C = +125^{\circ}C$   
Subgroup 3,6  $T_A = T_C = -55^{\circ}C$
- ⑦ Electrical specifications are derated for power supply voltages other than  $\pm 15VDC$ .

## APPLICATION NOTES

### HEAT SINKING

To determine if a heat sink is necessary for your application and if so, what type, refer to the thermal model and governing equation below.

#### Thermal Model:

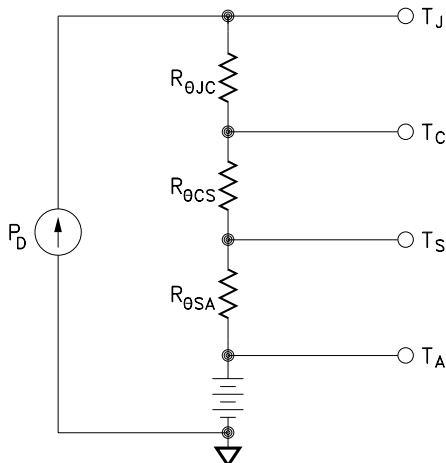

#### Governing Equation:

$$T_J = P_D \times (R_{\theta JC} + R_{\theta CS} + R_{\theta SA}) + T_A$$

Where

$T_J$  = Junction Temperature

$P_D$  = Total Power Dissipation

$R_{\theta JC}$  = Junction to Case Thermal Resistance

$R_{\theta CS}$  = Case to Heat Sink Thermal Resistance

$R_{\theta SA}$  = Heat Sink to Ambient Thermal Resistance

$T_C$  = Case Temperature

$T_A$  = Ambient Temperature

$T_S$  = Sink Temperature

#### Example:

This example demonstrates a worst case analysis for the op-amp output stage. This occurs when the output voltage is 1/2 the power supply voltage. Under this condition, maximum power transfer occurs and the output is under maximum stress.

Conditions:

$$V_{CC} = \pm 16\text{VDC}$$

$$V_o = \pm 8\text{Vp Sine Wave, Freq.} = 1\text{KHz}$$

$$R_L = 510\Omega$$

For a worst case analysis we treat the +8Vp sine wave as an 8VDC output voltage.

1.) Find driver power dissipation

$$\begin{aligned} P_D &= (V_{CC} - V_o) (V_o / R_L) \\ &= (16\text{V} - 8\text{V}) (8\text{V} / 510\Omega) \\ &= 125.5\text{mW} \end{aligned}$$

2.) For conservative design, set  $T_J = +125^\circ\text{C}$

3.) For this example, worst case  $T_A = +100^\circ\text{C}$

4.)  $R_{\theta JC} = 187^\circ\text{C/W}$  from MSK 032B Data Sheet

5.)  $R_{\theta CS} = 0.15^\circ\text{C/W}$  for most thermal greases

6.) Rearrange governing equation to solve for  $R_{\theta SA}$

$$\begin{aligned} R_{\theta SA} &= ((T_J - T_A) / P_D) - (R_{\theta JC}) - (R_{\theta CS}) \\ &= ((125^\circ\text{C} - 100^\circ\text{C}) / 0.13\text{W}) - 187^\circ\text{C/W} - 0.15^\circ\text{C/W} \\ &= 192.3 - 187.15 \\ &= 5.2^\circ\text{C/W} \end{aligned}$$

The heat sink in this example must have a thermal resistance of no more than  $5.2^\circ\text{C/W}$  to maintain a junction temperature of no more than  $+125^\circ\text{C}$ .

### SLEW RATE vs. SLEW RATE LIMIT

#### SLEW RATE

$SR = 2\pi V_p f$ : Slew rate is based upon the sinusoidal linear response of the amplifier and is calculated from the full power bandwidth frequency.

#### SLEW RATE LIMIT

$dv/dt$ : The slew rate limit is based upon the amplifier's response to a step input and is measured between 10% and 90%. MSK measures  $T_R$  or  $T_F$ , whichever is greater at  $\pm 10V_{OUT}$ ,  $R_L = 510\Omega$

$$SRL = \frac{V_o - 20\%}{T_R \text{ or } T_F}$$

### COMPENSATION

The MSK 032, can be frequency compensated by connecting an R-C snubber circuit from pin 3 to pin 4 as shown below.

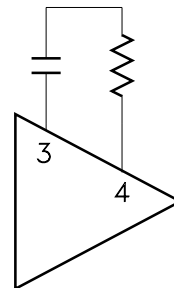

The recommended capacitor value is  $0.01\mu\text{F}$  and the resistor value can range from  $2\Omega$  to  $500\Omega$ . The effects of this R-C snubber can be seen on the typical performance curve labeled Slew Rate vs. Compensation Resistance. The graph clearly illustrates the decrease in transition time as snubber resistance increases. This occurs because the high frequency components of the input square wave are above the corner frequency of the R-C snubber and are applied common mode to the bases of the second differential pair, (pins 3 and 4). There is no differential gain for these higher frequencies since the input signal is applied common mode. Without the high frequency components appearing at the output, the slew rate and bandwidth of the op-amp are limited. However, at the cost of speed and bandwidth the user gains circuit stability. A good design rule to follow is: as closed loop gain decreases, circuit stability decreases, therefore snubber resistance should decrease to maintain stability and avoid oscillation. The MSK 032 can also be compensated using the standard LH0032 techniques.

### POWER SUPPLY BYPASSING

Both the negative and positive power supplies must be effectively decoupled with a high and low frequency bypass circuit to avoid power supply induced oscillation. An effective decoupling scheme consists of a 0.1 microfarad ceramic capacitor in parallel with a 4.7 microfarad tantalum capacitor from each power supply pin to ground.

# TYPICAL PERFORMANCE CURVES

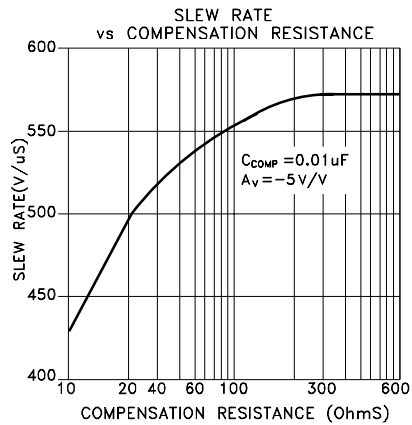
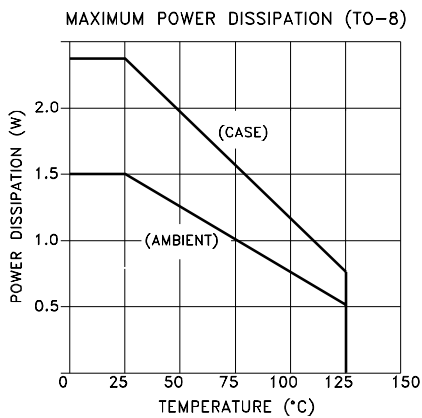
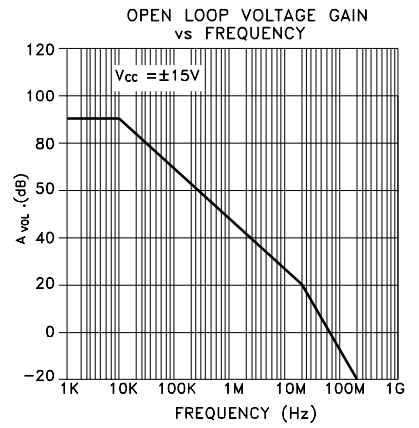
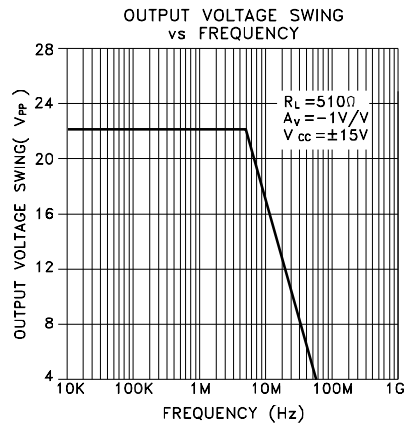
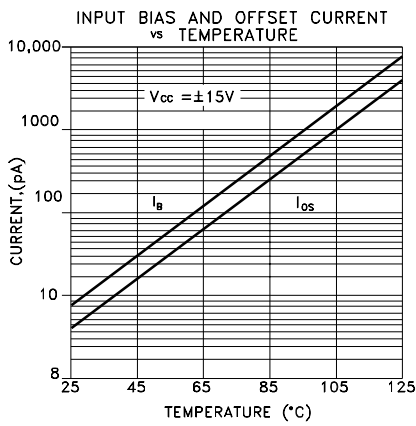
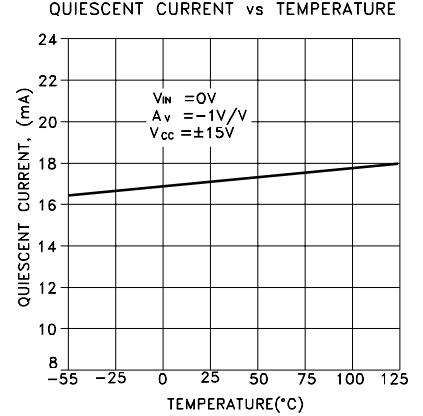
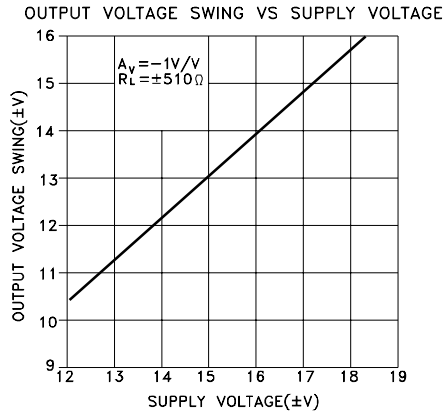
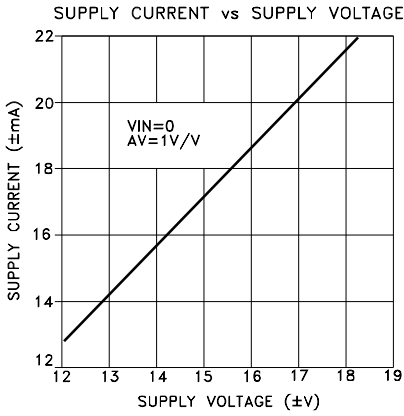

## MECHANICAL SPECIFICATIONS

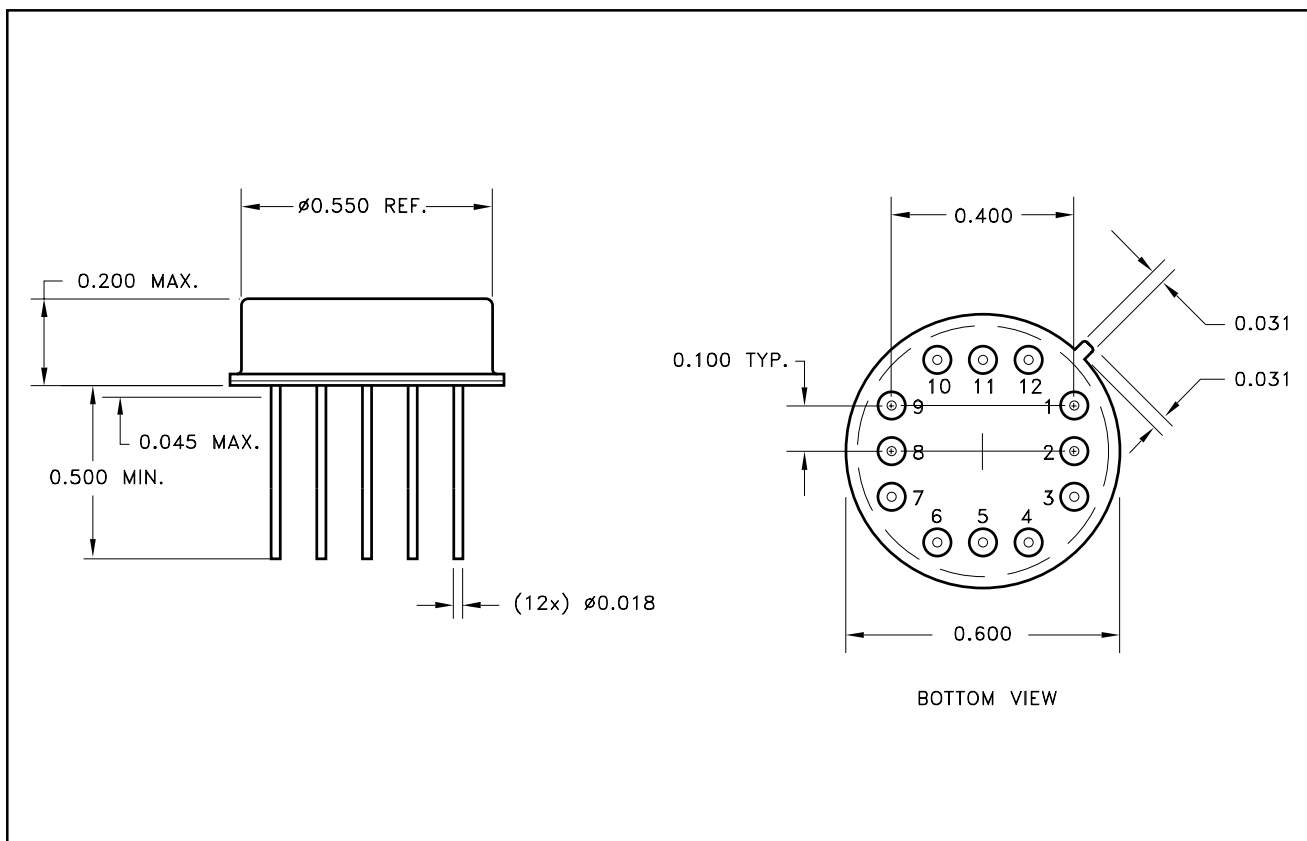

ALL DIMENSIONS ARE  $\pm 0.010$  INCHES UNLESS OTHERWISE LABELED

## ORDERING INFORMATION

| Part Number | Screening Level       |
|-------------|-----------------------|
| MSK032      | Industrial            |
| MSK032E     | Extended Reliability  |
| MSK032B     | Mil-PRF-38534 Class H |
| MSK032S     | Mil-PRF-38534 Class K |

M.S. Kennedy Corp.  
 4707 Dey Road, Liverpool, New York 13088  
 Phone (315) 701-6751  
 FAX (315) 701-6752  
[www.mskennedy.com](http://www.mskennedy.com)

The information contained herein is believed to be accurate at the time of printing. MSK reserves the right to make changes to its products or specifications without notice, however, and assumes no liability for the use of its products. Please visit our website for the most recent revision of this datasheet.