



PWM-Embedded 3x4-Channel Constant-Current Sink Driver for LED Strips

Features

- Supply voltage
 - 6V~24V by internal LDO
 - 3.3V/5V direct input
- 3x4-channel constant-current sink driver for LED strips
 - Constant current range:
 - 3~45mA @ $V_{DD}=6 \sim 24V$ or $V_{DD}=V_{CA}=5V$
 - 3~30mA @ $V_{DD}=V_{CA}=3.3V$
 - 3 groups of current gain
 - Sustaining voltage at output channels: 28V (max.)
- Embedded 16-bit PWM generator
 - Gray scale clock generated by the embedded oscillator
 - 16-bit S-PWM patented technology
- Reliable data transmission
 - Daisy-chain topology
 - Two-wire transmission interface
 - Phase-inversed output clock
 - Built-in buffer for long distance transmission
- RoHS-compliant packages
 - SSOP-24
 - TSSOP-24
 - QFN-24

Application

- LED strips
- Mesh display
- Architectural lighting

Shrink SOP

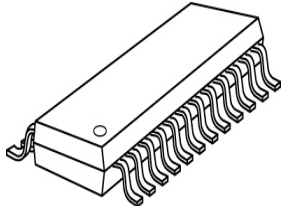

GP: SSOP24L-150-0.64

Thin Shrink SOP

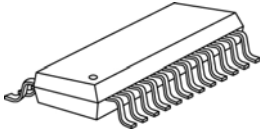

GTS: TSSOP24L-173-0.65

Quad Flat No-Lead

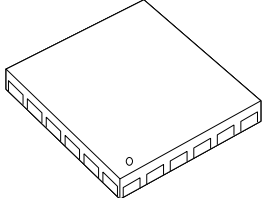

GFN: QFN24L-4*4-0.5

Product Description

MBI6033 is a 3x4-channel, constant-current, PWM-embedded sink driver for LED strips. MBI6033 provides constant current ranging from 3mA to 45mA for each output channel and are adjustable through only single external resistor and corresponding current gain settings. Besides, MBI6033 supports 6~24V wide range power systems and sustains 28V at output channels.

With Scrambled-PWM (S-PWM) technology, MBI6033 enhances pulse width modulation by scrambling the “on” time into several “on” periods to increase visual refresh rate at the same gray scale performance. Besides, the gray scale clock (GCLK) is generated by the embedded oscillator. Moreover, MBI6033 provides 16-bit gray scale which provides 65,536 gray scales for each LED to enrich the color.

3 independent 7-bit current gain settings are built-in MBI6033, so the user can set independent output current for R/G/B LED by a single current set resistor and current gain instead of 3 current set resistors.

In addition, MBI6033 features a two-wire transmission interface to make cluster-to-cluster connection easier. To improve the transmission quality, MBI6033 provides phase-inversed output clock to eliminate the accumulation of signal pulse width distortion. MBI6033 adopts manual-synchronization to maintain the synchronization of image frames between ICs.

Pin Configuration

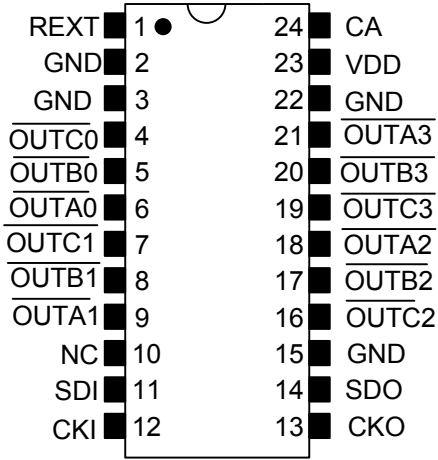

MBI6033GP
Top View

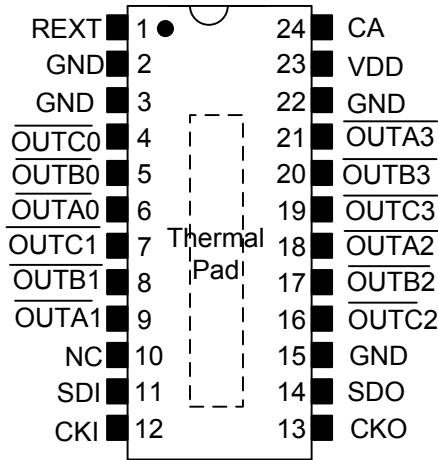

MBI6033GTS
Top View

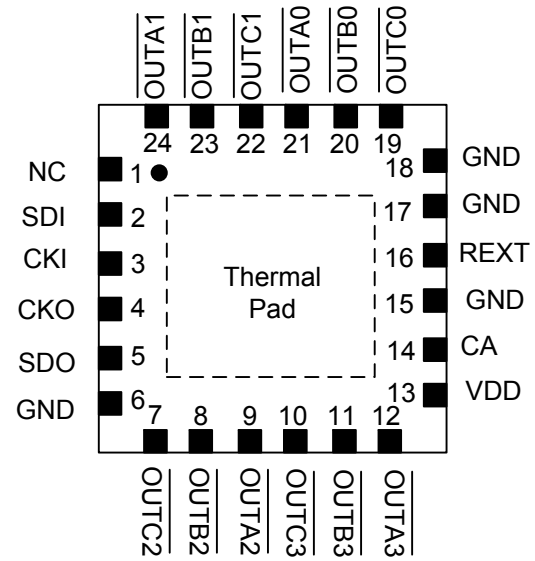

MBI6033GFN
Top View

Terminal Description

Pin			Names	Attribute	Description and function
GP	GTS*	GFN*			
1	1	16	REXT	O	Input terminals for setting output current by connecting to an external resistor
2, 3, 15, 22	2, 3, 15, 22	6, 15, 17, 18	GND	P	Ground terminal
4, 5, 6	4, 5, 6	19, 20, 21	$\overline{\text{OUTA0,B0,C0}}$	O	Output terminals for constant-current output
7, 8, 9	7, 8, 9	22, 23, 24	$\overline{\text{OUTA1,B1,C1}}$	O	Output terminals for constant-current output
10	10	1	NC	-	Leave it unconnected
11	11	2	SDI	I	Input terminal for serial data input
12	12	3	CKI	I	Input terminal for clock input
13	13	4	CKO	O	Output terminal for clock output
14	14	5	SDO	O	Output terminal for serial data input
16, 17, 18	16, 17, 18	10, 11, 12	$\overline{\text{OUTA2,B2,C2}}$	O	Output terminals for constant-current output
19, 20, 21	19, 20, 21	7, 8, 9	$\overline{\text{OUTA3,B3,C3}}$	O	Output terminals for constant-current output
23	23	13	VDD	P	Input voltage, 3.3V/5V/6~24V
24	24	14	VCA	O	Connecting a capacitor to GND to enhance the stability of CA

*The desired thermal conductivity will be improved on condition that a heat-conducting copper foil on PCB is soldered with thermal pad.

Typical Application Circuit

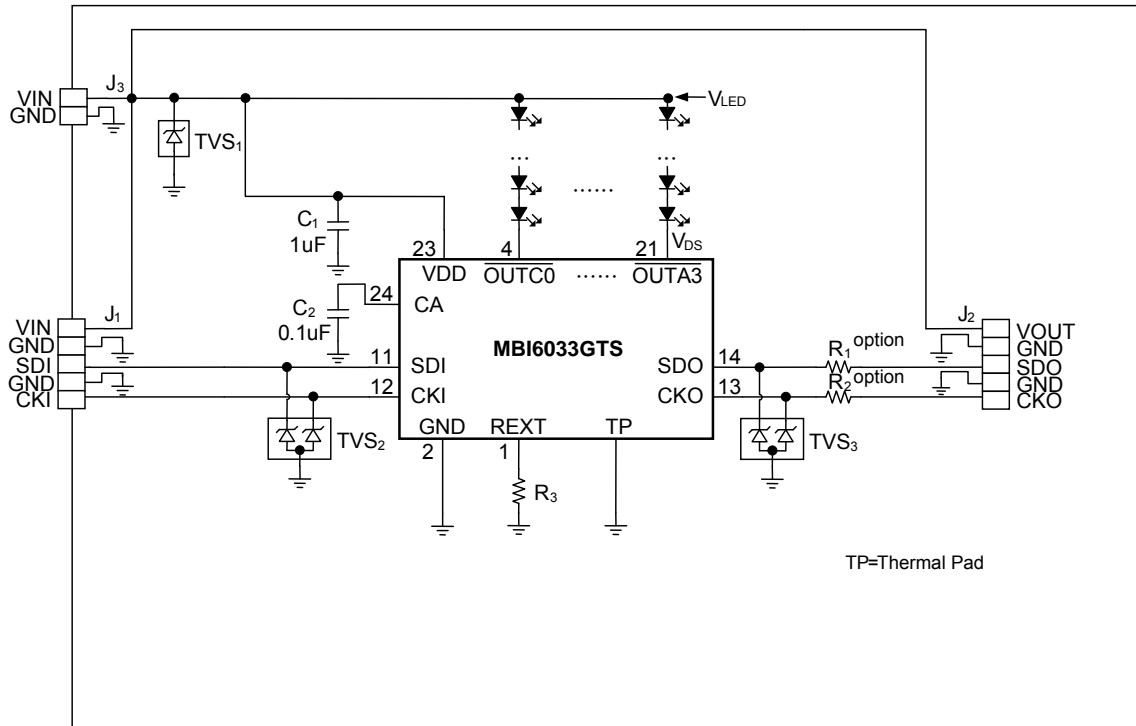

Note:

1. TVS₁~TVS₃ are Transient Voltage Suppressor (TVS).
2. C₁~C₂ are required. The values of the C₁~C₂ are reference only. Tantalum capacitors and Ceramic capacitors are recommended.
3. For hot plug, system grounding, connector design, external ESD protection, or detailed circuit information, please refer to the **“MBI6033 Application Note”** for detailed information.

Block Diagram

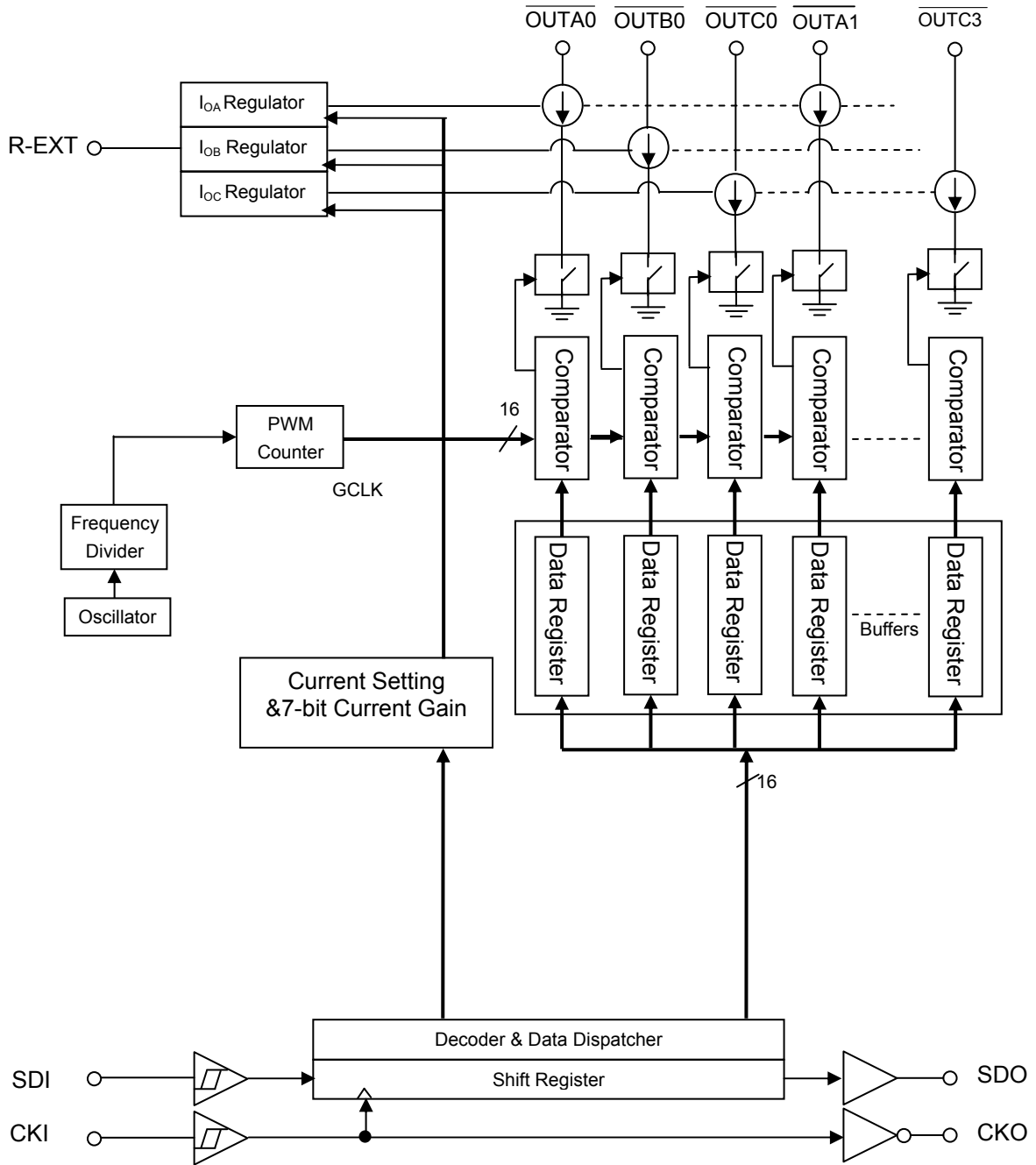

Equivalent Circuits of Inputs and Outputs

CKO, SDO terminals

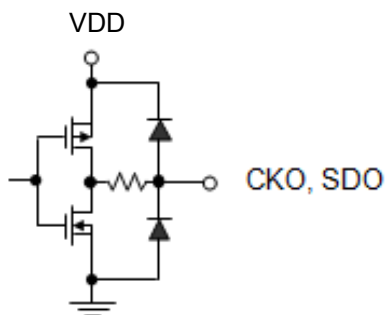

CKI, SDI terminals

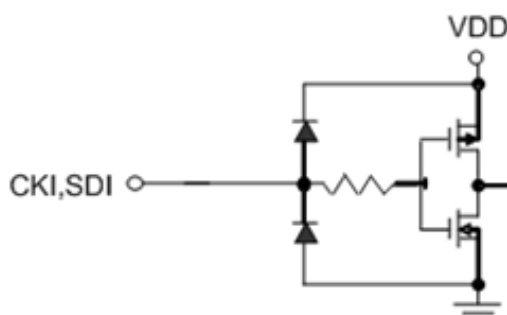

REXT terminals

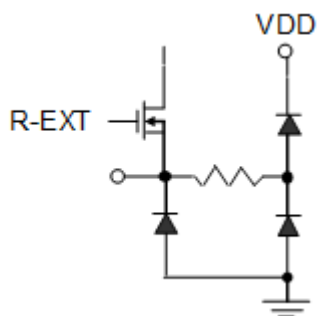

OUTAn, Bn, Cn terminal

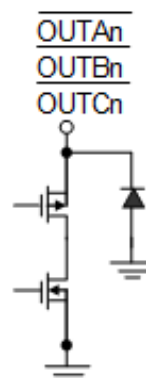

Maximum Rating

Characteristic		Symbol	Rating	Unit
Supply Voltage		V_{DD}	0~28	V
LDO Output Voltage		V_{CA}	0~7	V
Sustaining Voltage at CKI, SDI Pins		V_{IN}	$-0.4 \sim V_{CA} + 0.4$	V
Sustaining Voltage at CKO, SDO Pins		V_{OUT}	$-0.4 \sim V_{CA} + 0.4$	V
Sustaining Voltage at \overline{OUTn} Pins		V_{DS}	-0.5~+28	V
Output Current per Output Channel		I_{OUT}	+50	mA
GND Terminal Current		I_{GND}	630	mA
Heat dissipation (On 4-Layer PCB, $T_a=25^\circ\text{C}$)*	GP	P_D	1.76	W
	GTS	P_D	2.14	W
	GFN	P_D	3.19	W
Thermal Resistance (By simulation, on 4-Layer PCB)*	GP	$R_{th(j-a)}$	70.9	$^\circ\text{C/W}$
	GTS	$R_{th(j-a)}$	58.45	$^\circ\text{C/W}$
	GFN	$R_{th(j-a)}$	39.15	$^\circ\text{C/W}$
Junction Temperature		$T_{j,max}$	150**	$^\circ\text{C}$
Operating Ambient Temperature		T_{opr}	-40~+85	$^\circ\text{C}$
Storage Temperature		T_{stg}	-55~+150	$^\circ\text{C}$
ESD Rating	Human Body Mode (MIL-STD-883G Method 3015.7)	HBM	Class 2 (2000V to 3999V)	-
	Machine Mode (JEDEC EIA/JESD22-A115,)	MM	Class M3 (200V to 399V)	-

*The PCB size is 76.2mm*114.3mm in simulation. Please refer to JEDEC JESD51.

** Operation at the maximum rating for extended periods may reduce the device reliability; therefore, the suggested junction temperature of the device is under 125°C.

Note: The performance of thermal dissipation is strongly related to the size of thermal pad, thickness and layer numbers of the PCB. The empirical thermal resistance may be different from simulative value. Users should plan for expected thermal dissipation performance by selecting package and arranging layout of the PCB to maximize the capability.

Electrical Characteristics

($V_{DD}=6.0\sim 24.0V$ or $V_{DD}=V_{CA}=5V$, $T_a=25^\circ C$)

Characteristics		Symbol	Condition	Min.	Typ.	Max.	Unit	
Supply Voltage		V_{DD}	-	6	-	24	V	
			$V_{DD}=V_{CA}$	4.5	5	5.5		
Sustaining Voltage at OUT Ports		V_{DS}	$\overline{OUTAn} \sim \overline{OUTCn} = \text{Off}$	-	-	28	V	
Output Current		I_{OUT}	Refer to "Test Circuit for Electrical Characteristics"	5	-	45	mA	
Driving Current			I_{OH}	CKO, SDO at $V_{OH}=V_{CA}-0.2V$	1.5	2.5	4.5	mA
			I_{OL}	CKO, SDO at $V_{OH}=0.2V$	1.0	2.0	4.0	mA
Output Leakage Current		I_{OUT}	$V_{DS}=28.0V$, $\overline{OUTAn} \sim \overline{OUTCn} = \text{Off}$	-	-	1.0	μA	
Current Skew (Channel)		dI_{OUT1}	$I_{OUT}=20mA$ $V_{DS}=1.0V$ $R_{ext}=680\Omega$	-	± 1.5	± 3.0	%	
Current Skew (IC)		dI_{OUT2}	$I_{OUT}=20mA$ $V_{DS}=1.0V$ $R_{ext}=680\Omega$	-	± 1.5	± 6.0	%	
Output Current vs. Output Voltage Regulation*		$\%/dV_{DS}$	V_{DS} within 1.0V and 3.0V	-	± 0.1	± 0.5	$\%/V$	
Output Current vs. Supply Voltage Regulation*		$\%/dV_{DD}$	V_{DD} within 6V and 24V	-	± 1.0	± 2.0	$\%/V$	
Input Voltage of CKI and SDI Pins	"H" level	V_{IH}	-	2.0	-	V_{CA}	V	
	"L" level	V_{IL}	-	GND	-	0.8	V	
Output Voltage of CKO and SDO Pins	"H" level	V_{OH}	$I_{OH}=+2.0mA$	$V_{CA}-0.2$	-	-	V	
	"L" level	V_{OL}	$I_{OL}=-2.0mA$	-	-	0.2	V	
Voltage at R-EXT		V_{REXT}	$\overline{OUTAn} \sim \overline{OUTCn} = \text{On}$	0.58	0.617	0.64	V	
Knee Voltage*		V_{Knee}	$R_{ext}=467\Omega$ at $I_{OUT}=30mA$	-	0.75	0.8	V	
Supply Current**	"Off"	$I_{DD}(\text{off})$	All channel off ,REXT open	2.0	3.0	4.5	mA	
			$R_{ext}=680\Omega$, CKI, SDI=Low, CKO, SDO=NC, $\overline{OUTAn} \sim \overline{OUTCn} = \text{Off}$	6.0	8.0	10		
	"On"	$I_{DD}(\text{on})$	$R_{ext}=680\Omega$, CKI, SDI=Low, CKO, SDO=NC, $\overline{OUTAn} \sim \overline{OUTCn} = \text{On}$	7.0	9.0	11		
			$R_{ext}=680\Omega$, CKI=10MHz, CKO, SDO=NC, $\overline{OUTAn} \sim \overline{OUTCn} = \text{On}$	15	18	21		

*One channel turns on.

** The supply current may vary with the loading conditions.

Electrical Characteristics

($V_{DD}=V_{CA}=3.3V$, $T_a=25^{\circ}C$)

Characteristics		Symbol	Condition	Min.	Typ.	Max.	Unit
Supply Voltage		V_{DD}	$V_{DD}=V_{CA}$	3.0		3.6	V
Sustaining Voltage at OUT Ports		V_{DS}	$\overline{OUTAn} \sim \overline{OUTCn} = \text{Off}$	-	-	28.0	V
Output Current		I_{OUT}	Refer to "Test Circuit for Electrical Characteristics"	3	-	30	mA
Driving Current		I_{OH}	CKO, SDO at $V_{OH}=V_{CA}-0.2V$	1.5	2.5	4.5	mA
		I_{OL}	CKO, SDO at $V_{OH}=0.2V$	1.0	2.0	4.0	mA
Output Leakage Current		I_{OUT}	$V_{DS}=28.0V$, $\overline{OUTAn} \sim \overline{OUTCn} = \text{Off}$	-	-	1.0	μA
Current Skew (Channel)		dI_{OUT1}	$I_{OUT}=20mA$ $V_{DS}=1.0V$ $R_{ext}=680\Omega$	-	± 1.5	± 3.0	%
Current Skew (IC)		dI_{OUT2}	$I_{OUT}=20mA$ $V_{DS}=1.0V$ $R_{ext}=680\Omega$	-	± 1.5	± 6.0	%
Output Current vs. Output Voltage Regulation*		$\%/dV_{DS}$	V_{DS} within 1.0V and 3.0V	-	± 0.1	± 0.5	%/V
Output Current vs. Supply Voltage Regulation*		$\%/dV_{DD}$	V_{DD} within 3.0V and 3.6V	-	± 1.0	± 2.0	%/V
Input Voltage of CKI, SDI Pins	"H" level	V_{IH}	-	2.0	-	V_{CA}	V
	"L" level	V_{IL}	-	GND	-	0.8	V
Output Voltage of CKO, SDO Pins	"H" level	V_{OH}	$I_{OH}=+2.0mA$	$V_{CA}-0.2$	-	-	V
	"L" level	V_{OL}	$I_{OL}=-2.0mA$	-	-	0.2	V
Voltage at R-EXTA,B,C Pins		V_{REXT}	$\overline{OUTAn} \sim \overline{OUTCn} = \text{On}$	0.58	0.617	0.64	V
Knee Voltage*		V_{Knee}	$R_{ext}=467\Omega$ at $I_{OUT}=30mA$		0.80	0.85	V
Supply Current**	"Off"	$I_{DD}(\text{off})$	All channel off, REXT open	2.0	3.0	4.5	mA
			$R_{ext}=360\Omega$, CKI,SDI=Low, CKO, SDO= NC, $\overline{OUTAn} \sim \overline{OUTCn} = \text{Off}$	5.0	7.0	9.0	
	"On"	$I_{DD}(\text{on})$	$R_{ext}=680\Omega$, CKI,SDI=Low, CKO, SDO=NC, $\overline{OUTAn} \sim \overline{OUTCn} = \text{On}$	6.0	8.0	10.0	
$R_{ext}=680\Omega$, CKI=10MHz, CKO, SDO=NC, $\overline{OUTAn} \sim \overline{OUTCn} = \text{On}$			14.0	17.0	20.0		

*One channel turns on.

**The supply current may vary with the loading conditions.

Switching Characteristics

($V_{DD}=6.0\sim 24.0V$; $V_{CA}=V_{DD}=5V$, $T_a=25^\circ C$)

Characteristic		Symbol	Condition	Min.	Typ.	Max.	Unit	
Propagation delay time ("H" to "L" or "L" to "H")	CKI↑-CKO↓	t_{P1}	VLED=5V CL=10pF Vds=1V R _{ext} =680Ω R _L =200Ω	11	16	21	ns	
	CKO↓-SDO	t_{P2}		15	25	35	ns	
	CKO↓-SDI	t_{P5}		15	25	35	ns	
	GCLK ↑ - $\overline{OUTA0}$, $\overline{OUTA1}$, $\overline{OUTA2}$, $\overline{OUTA3}$ ↓ ↑	t_{P7}		32	40	48	ns	
	GCLK ↑ - $\overline{OUTB0}$, $\overline{OUTB1}$, $\overline{OUTB2}$, $\overline{OUTB3}$ ↓ ↑	t_{P8}		40	48	56	ns	
	GCLK ↑ - $\overline{OUTC0}$, $\overline{OUTC1}$, $\overline{OUTC2}$, $\overline{OUTC3}$ ↓ ↑	t_{P9}		48	56	64	ns	
Rise Time	CKO/SDO/SDI	t_{CR}		2	5	8	ns	
	$\overline{OUTA} \sim \overline{OUTC}$	t_{OR1}		20	30	40	ns	
Fall Time	CKO/SDO/SDI	t_{CF}		2	5	8	ns	
	$\overline{OUTA} \sim \overline{OUTC}$	t_{OF1}		20	30	40	ns	
Hold Time Setup Time	SDI-CKI↓	$t_{H(D)}$		8	-	-	ns	
	CKI↓-SDI	$t_{S(D)}$		8	-	-	ns	
Pulse Width	CKI	t_w		15	-	-	ns	
Frequency	CKI	F_{CKI}		Flat(AWG26), 50cm distance	0.2	-	10	MHz
	PWM clock	F_{PCKL}		-	8.0	10	12.0	MHz
	Internal oscillator	-		-	8.0	10	12.0	MHz
Timeout period**		$t_{timeout}$	-	21	-	-	us	

Note:

*The maximum frequency may be limited by different application conditions. Please refer to the application note for details.

**The period of internal OSC is 8MHz (min.) ~ 12MHz (max.), so the time-out period is 168x83.3ns (13.9us) ~ 168x125ns (21us). Please refer to time out mechanism section.

***The Gray Scale Clock Frequency is 12MHz (max.) when the GCLK=frequency of internal oscillator.

Switching Characteristics

($V_{DD}=V_{CA}=3.3V$, $T_a=25^{\circ}C$)

Characteristic		Symbol	Condition	Min.	Typ.	Max.	Unit
Propagation delay time ("H" to "L" or "L" to "H")	CKI↑-CKO↓	t_{P1}	VLED=5V CL=10pF Vds=1V R _{ext} =680Ω R _L =200Ω	18	23	28	ns
	CKO↓-SDO	t_{P2}		20	30	40	ns
	CKO↓-SDI	t_{P5}		20	30	40	ns
	GCLK ↑ - $\overline{OUTA0}$, $\overline{OUTA1}$, $\overline{OUTA2}$, $\overline{OUTA3}$ ↓ ↑	t_{P7}		32	40	48	ns
	GCLK ↑ - $\overline{OUTB0}$, $\overline{OUTB1}$, $\overline{OUTB2}$, $\overline{OUTB3}$ ↓ ↑	t_{P8}		40	48	56	ns
	GCLK ↑ - $\overline{OUTC0}$, $\overline{OUTC1}$, $\overline{OUTC2}$, $\overline{OUTC3}$ ↓ ↑	t_{P9}		48	56	64	ns
Rise Time	CKO/SDO/SDI	t_{CR}		2	5	8	ns
	OUTA ~ \overline{OUTC}	t_{OR1}		25	35	45	ns
Fall Time	CKO/SDO/SDI	t_{CF}		2	5	8	ns
	OUTA ~ \overline{OUTC}	t_{OF1}	25	35	45	ns	
Hold Time	SDI-CKI↓	$t_{H(D)}$	10	-	-	ns	
Setup Time	CKI↓-SDI	$t_{S(D)}$	10	-	-	ns	
Pulse Width	CKI	t_W	15	-	-	ns	
Frequency	CKI	F_{CKI}	Flat(AWG26), 50cm distance	0.2	-	10	MHz
	PWM clock	F_{PCKL}	-	9.0	11.0	13.0	MHz
	Internal oscillator	-	-	9.0	11.0	13.0	MHz
Timeout period**		$t_{timeout}$		18.6	-	-	us

Note:

*The maximum frequency may be limited by different application conditions. Please refer to the application note for details.

**The period of internal OSC is 9MHz (min.) ~ 13MHz (max.), so the time-out period is 168x76.9ns (12.9us) ~ 168x111.1ns (18.6us). Please refer to time out mechanism section.

***The Gray Scale Clock Frequency is 13MHz (max.) when the GCLK=frequency of internal oscillator.

Test Circuit for Electrical / Switching Characteristics

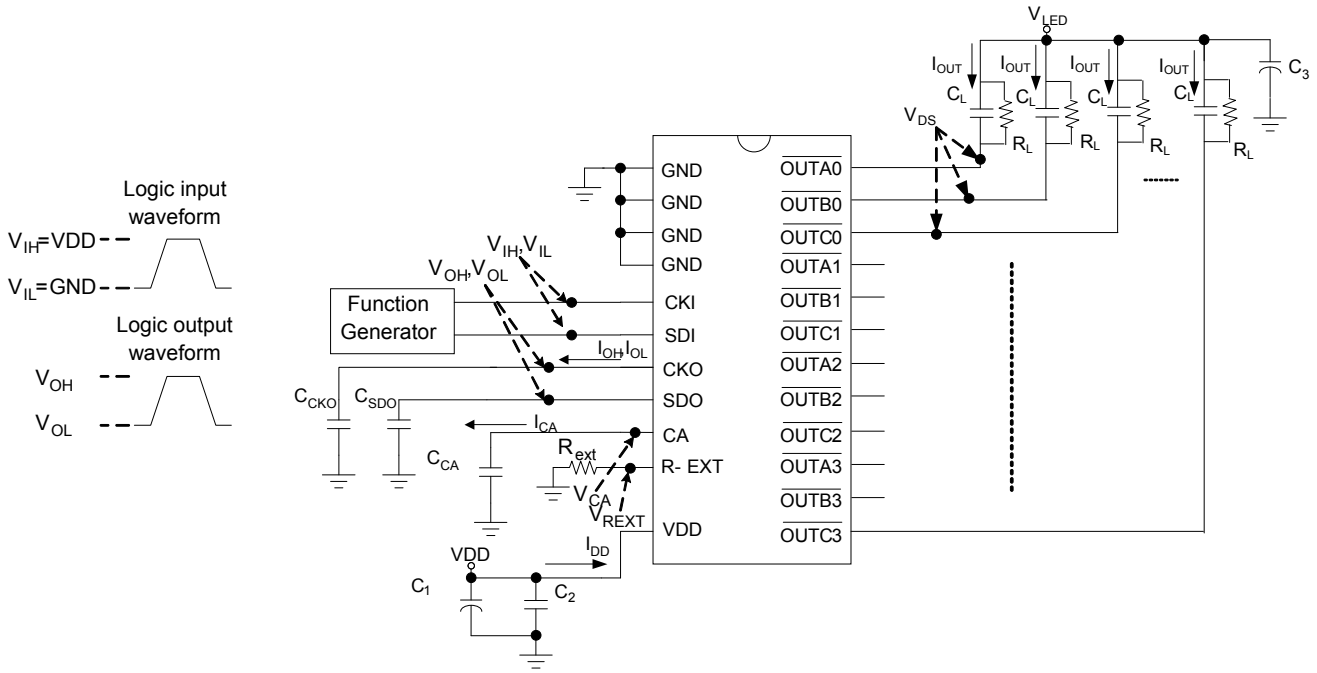

Timing Waveform

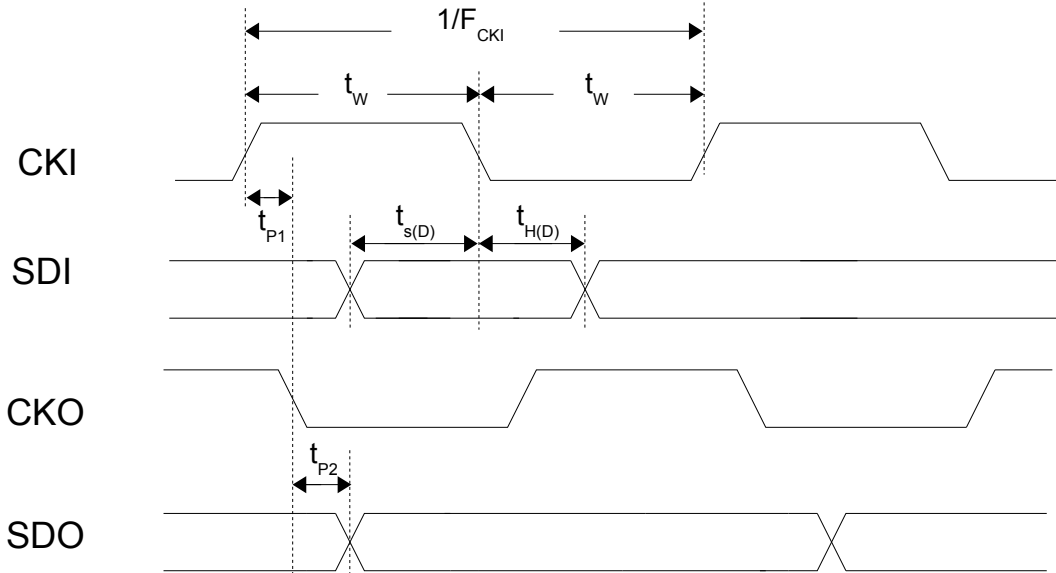

Note: Odd IC means 1st, 3rd, 5th ... ICs connected to controller

Output Timing

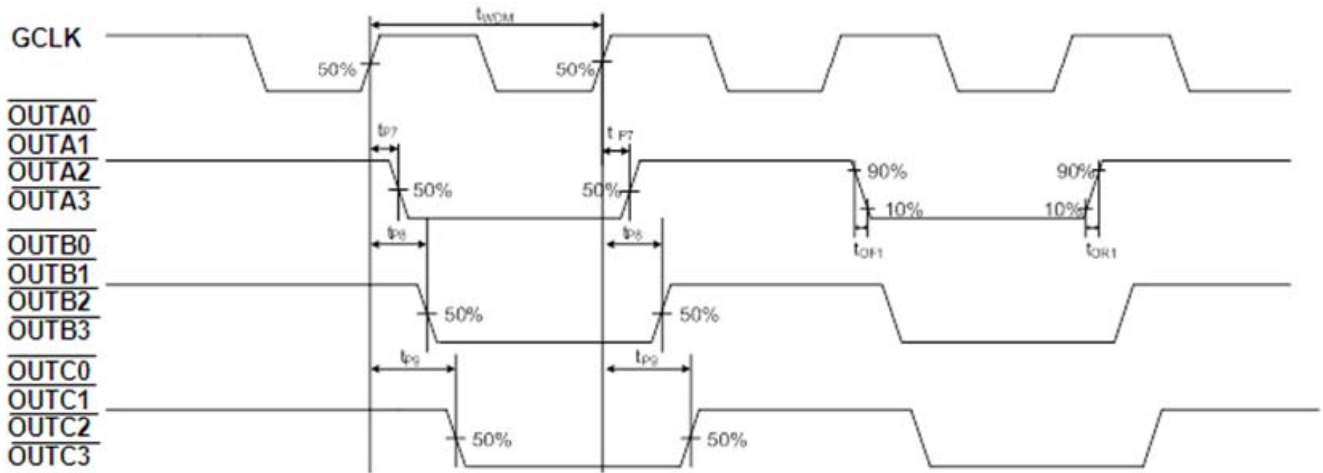

Data programming sequence

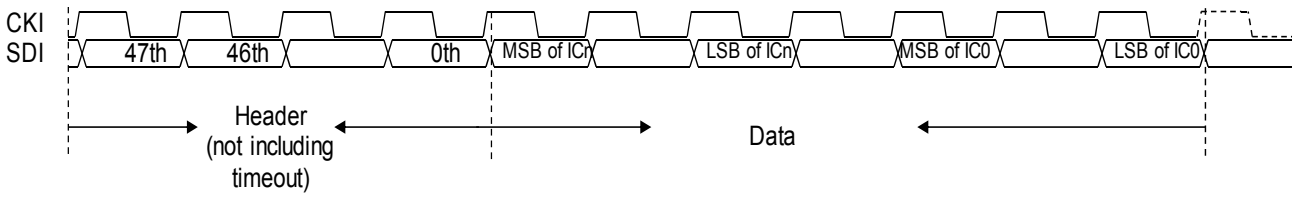

The above figure shows an application example of MBI6033. The drivers are connected serially and the data sequence sent by the controller is shown in Fig. 6. All commands are composed of “Header” and “Data”, as shown in the above figure.

The programming data sequence is from ICn, ICn-1, ... to IC0 and for each IC, MSB bit is sent first.

(Please also refer to sec. of “The structure of data packet”)

Control Interface

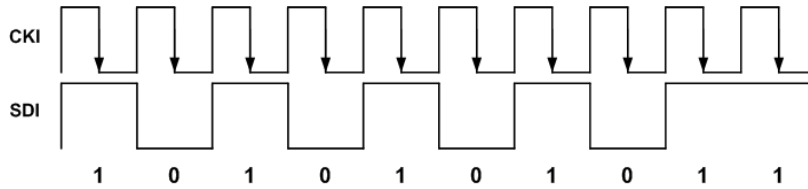

MBI6033 adopts the SPI-like interface (CKI/SDI). By SPI-like interface, MBI6033 samples the data (SDI) at the falling edge of the clock (CKI).The above waveform is the example of the SPI-like interface.

Principle of Operation

MBI6033 receives the data packet containing targeted gray scale data from the controller, and turns on the output channels according to the gray scale data. The gray scale clock of PWM generator, GCLK, is generated by the embedded oscillator. MBI6033 provides SPI-like interface (CKI, SDI), a two-wire only transmission interface, to address the data, so that MBI6033 receives the data directly without latching data.

Input Voltage Regulation

MBI6033 integrates a LDO which can convert 6~24V input voltage to 5V to supply the internal circuit. A user can connect a capacitor in CA pin to compensate LDO. Although CA is an output pin, the driving current is very tiny. Do not use the output of CA pin to drive any device. If a user would like to power MBI6033 by regulated 5V or 3.3V, connect both V_{DD} and CA pins to regulated 5V or 3.3V.

Gray Scale Control

MBI6033 provides 16-bit S-PWM gray scale mode to 64 segments, so that the visual refresh rate can be increased. For example, with S-PWM, the default PWM clock frequency is 12MHz, so, the visual refresh rate of 16-bit gray scale mode will be increased to 12MHz/65,536x64=11.72KHz

MBI6033 continuously repeats the PWM cycle and turns on the output ports according to the image data until the next image data is correctly recognized. Once the next input data is correctly recognized, MBI6033 will stop the present PWM cycle and restart a new PWM cycle to show the new data immediately.

16-bit gray scale data

The following is the equation for the duty cycle of output in 16-bit gray scale mode.

$$\text{the duty cycle of output (\%)} = \frac{\text{16-bit gray scale data}}{65536} \times 100\%$$

According to the above equation, the following table shows the examples:

Table 1. 16-bit gray mode scale output result

Example	Gray scale data	Duty Cycle of Output
1	65,535	99.9%
2	32,768	50%
3	16,384	25%
	⋮	⋮

Phase-inversed Output Clock

MBI6033 enhances the capability of cascading MBI6033 by phase-inversed output clock function. By phase-inversed output clock, the clock phase will be inversed from CKI to CKO to eliminate the accumulation of the pulse width deviation. This improves the signal integrity of data transmission. The following chart illustrates the phase-inversed output clock results.

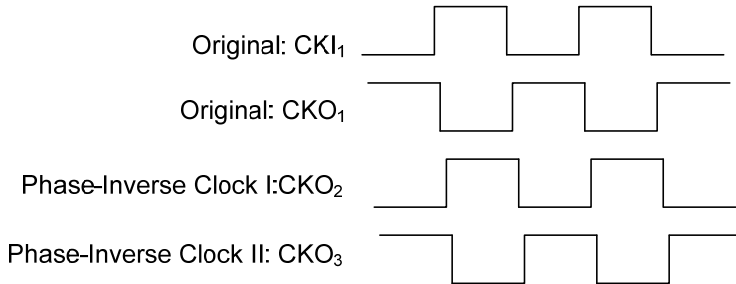

The Structure of Data Packet

MBI6033's data packet contains three parts:

1. Prefix:
The prefix is a symbol of "Silent-to-Reset", i.e. a time period for MBI6033 to distinguish two data packets.
2. Header:
The header defines the cascaded IC numbers and also contains a command to decide the data type.
3. Data:
This is the data for each IC. It may be gray scale data, dot correction data, or configuration data.

Structure of a data packet:

Prefix	Header	Data
--------	--------	------

Prefix

MBI6033 identifies the data as a new packet after time-out. Then users can follow the "time-out" protocol (time-out duration: stop $t_{out} + 1CKI + stop t_{out}$) to re-start packet decoding scheme.

If both CKI and SDI are tied-low and stop for more than the setting of CKI time-out period, MBI6033 will start to check the valid command of the next data packet. The prefix between two data packets helps MBI6033 identify the data packet correctly. The following timing diagram illustrates the interval between two data packets in 16-bit gray scale mode.

Time-out reset is to prevent ICs from misreading during the data transmission. The procedure is described below,

- The CKI should be tied-low and stop for more than time-out period
- > one CKI pulse (SDI keep)
- > CKI should be tied-low and stop for more than time-out period.

Where the time-out period is at least than 21 μ s.

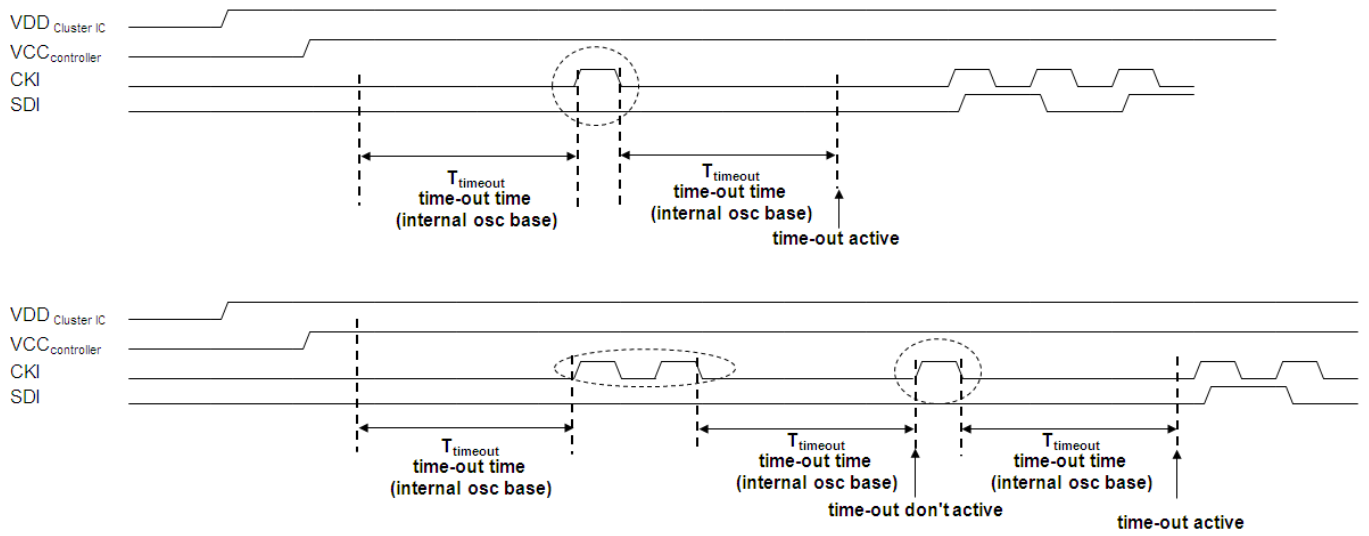

Setting the Data Types by the Command

MBI6033 provides three kinds of commands and input data types shown as the table below:

Command H[7:0]	Data Type
8'b11010101	Current gain mode
8'b11110011	Non-current gain mode
8'b11000001	Software reset

Once MBI6033 receives the SDI=1 (1'b1), MBI6033 will start to check if the data is a valid command or not. If the 8-bit data is a valid command, the driver will latch the specific data according to the protocol. If the 8-bit data is not a valid command, MBI6033 will wait for another SDI=1 (1'b1) to check the validity of the next command.

Time-Out Reset for Transmission Abort

Time-out reset is to prevent ICs from misreading during the data transmission. The procedure is described below,

The CKI should be tied-low and stop for more than time-out period

- > one CKI pulse (SDI keep)
- > CKI should be tied-low and stop for more than time-out period.

Where the time-out period is at least than 21 μ s.

Header Packet Format

48-bit header

Bit	Definition	Value	Function
47:40	H[7:0]	8'b11010101	Gray scale mode with current gain
		8'b11110011	Gray scale mode without current gain
39:26	S[13:0]	14'b0000000000000000	Wait counter data. Always send 14'b 0000000000000000
25:12	L[13:0]	N -1 N=Number of IC in series 14'bxxxx0000000000 ~ 14'bxxxx1111111111	Set the number of IC in series. The L[13:10] don't care. Only the L[9:0] are effective. For example: if we have 3 IC's in cascade, Length[13:0]=14'b0000 0000 0000 10
11:4	CF[7:0]	8'b00000000~8'b11111111	The configuration data. 8'b00000000 (default)
3:0	X1[3:0]	4'b0000	Reserved. Please keep "0000"

Configuration Mode

Bit	MSB				LSB			
	11	10	9	8	7	6	5	4
Default Value	0	000	00	0	0	0	0	0

Bit	Definition	Value	Function
11	Reserved	1'b0	The value is suggested to be "0"
10:8	GCLK frequency	000(default)	GCLK=frequency of internal oscillator, i.e. 10MHz (typ.).
		3'b001	GCLK=frequency of internal oscillator divided by 2, i.e. 5MHz (typ.).
		3'b 010	GCLK=frequency of internal oscillator divided by 4, i.e. 2.5MHz (typ.).
		3'b 011	GCLK=frequency of internal oscillator divided by 8, i.e. 1.25MHz (typ.).
		3'b 100	GCLK=frequency of internal oscillator divided by 16, i.e. 625KHz (typ.).
		3'b 101	GCLK=frequency of internal oscillator divided by 64, i.e. 156.25KHz (typ.).
		3'b 110	GCLK=frequency of internal oscillator divided by 128, i.e. 78.125KHz (typ.).
		3'b 111	GCLK=frequency of internal oscillator divided by 256, i.e.39.0625KHz (typ.).
7:6	Reserved	2'b00	Reserved. Please keep "00"
5	Output turn-on	1'b0	Turn-on the output "1", all constant-current outputs (OUTC3-OUTA0) are controlled by the GS PWM timing controller. "0", all constant-current outputs are forced off and PWM counter is reset to "0". Note: when this bit is from "0" to "1", PWM counter will be reset.
4	Reserved	1'b0	Reserved. Please keep "0"

Current Gain

24-bit current gain data

Bit	Definition	Value	Function
23:16	CGC _N [7]	1'b0	Reserved. Please keep "0"
	CGC _N [6:0]	7b'0000000~ 7b'1111111	The CGC _N [6:0] are 7 bits current gain data of Nth driver for $\overline{\text{OUTC}}$.
15:8	CGB _N [7]	1'b0	Reserved. Please keep "0"
	CGB _N [6:0]	7b'0000000~ 7b'1111111	The CGB _N [6:0] are 7 bits current gain data of Nth driver for $\overline{\text{OUTB}}$.
7:0	CGA _N [7]	1'b0	Reserved. Please keep "0"
	CGA _N [6:0]	7b'0000000~ 7b'1111111	The CGA _N [6:0] are 7 bits current gain data of Nth driver for $\overline{\text{OUTA}}$.

192-bit gray scale data

Bit	Definition	Value	Function
191:0	C3 _N [15:0]~ A0 _N [15:0]	Each channel is 16-bit. 16'h0000 ~ 16'hfff	16-bit x 12 channels gray scale data of the Nth driver. The data of $\overline{\text{OUTC}}_N$ is sent first.

The gray scale data of the last IC is sent first, followed by the previous ICs, and the first IC's gray scale data is sent in the end of the packet.

Example of 16-bit Gray Scale with Current Gain

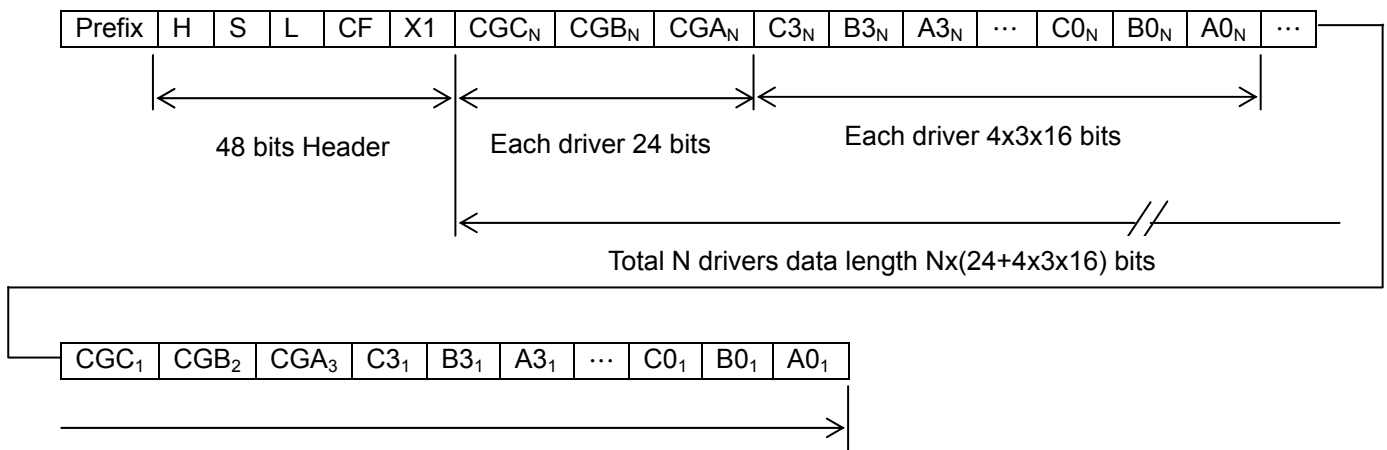

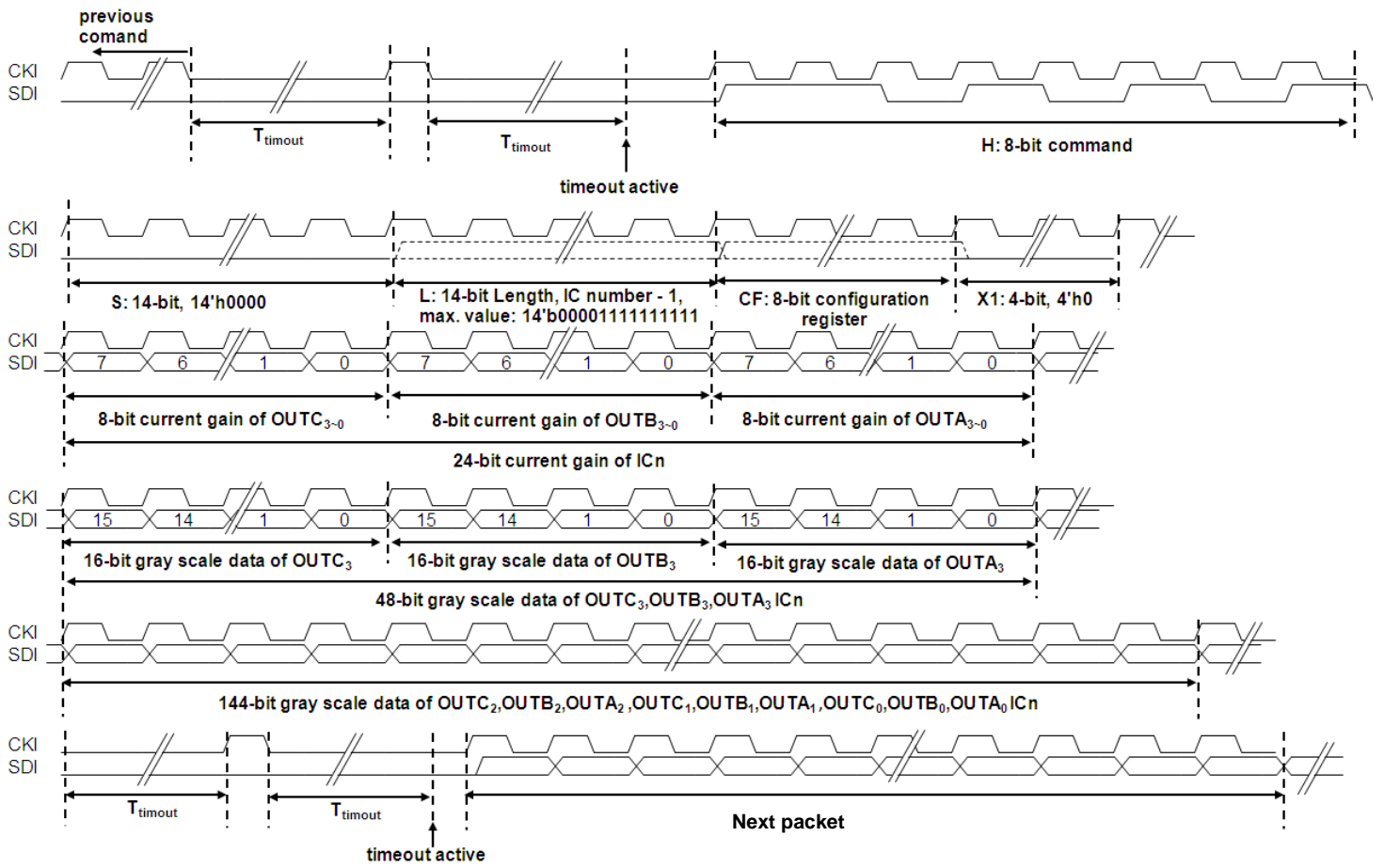

Example of 16-bit Gray Scale without Current Gain

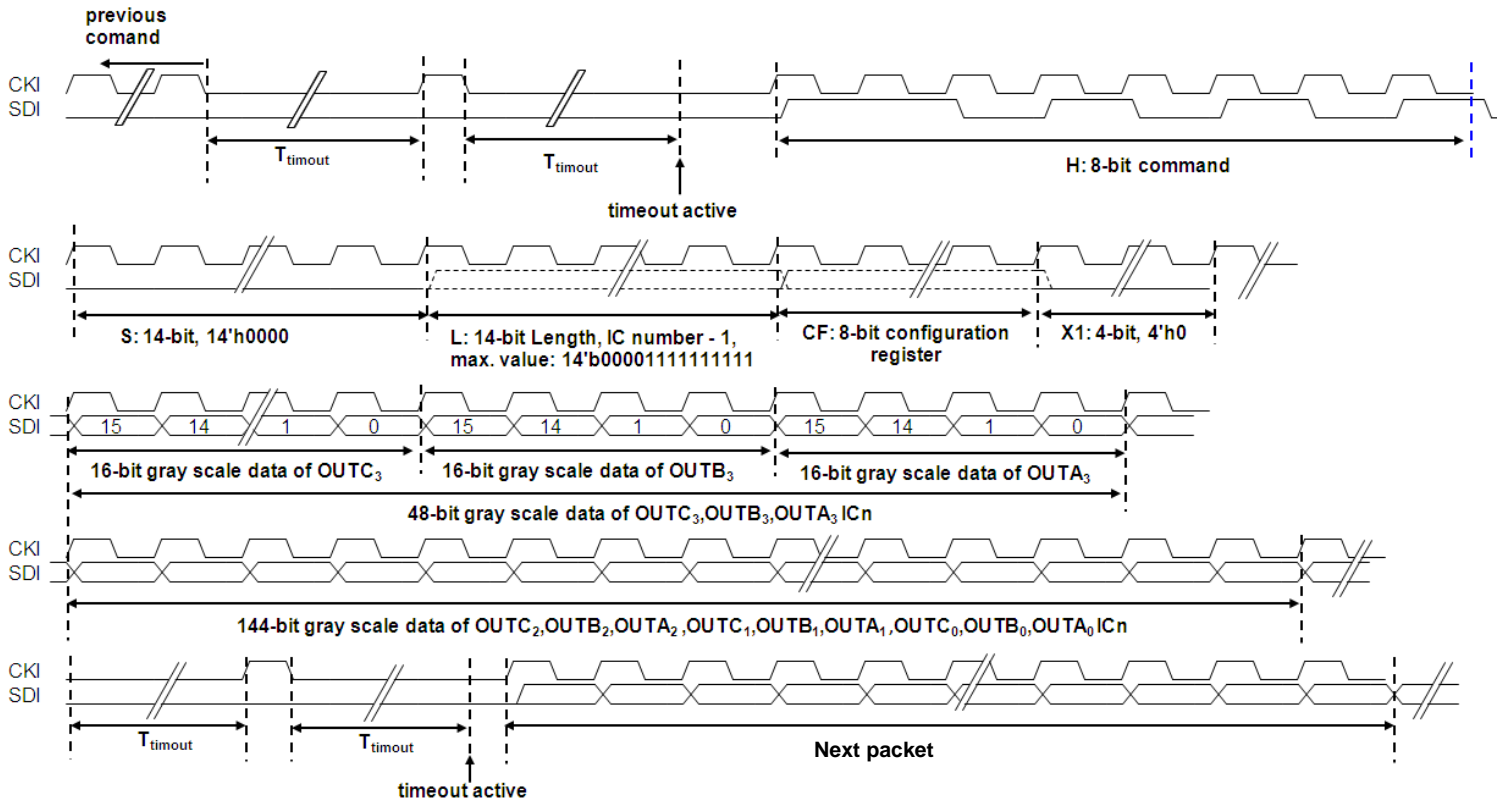
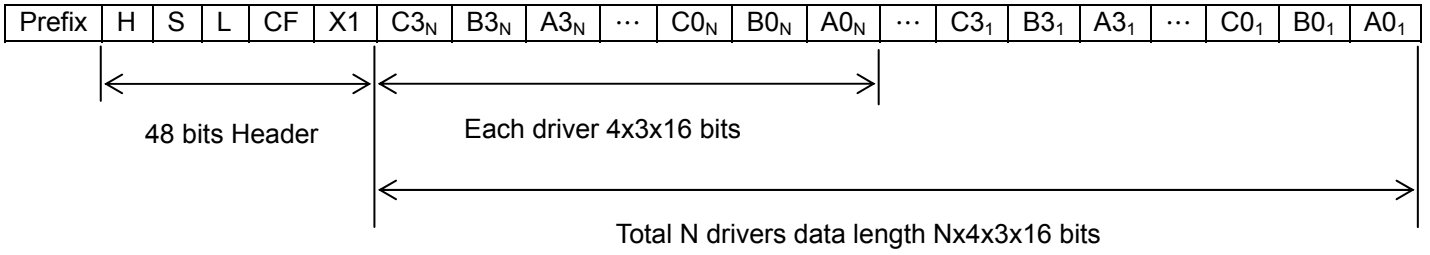

Constant Current

- 1) MBI6033 performs excellent current skew: the maximum current variation between channels is less than $\pm 3\%$, and that between ICs is less than $\pm 6\%$.
- 2) In addition, in the saturation region, the output current keeps constant when the output voltage (V_{DS}) is changed. This characteristic guarantees the LED show the same brightness regardless of the variations of LED forward voltages (V_F).

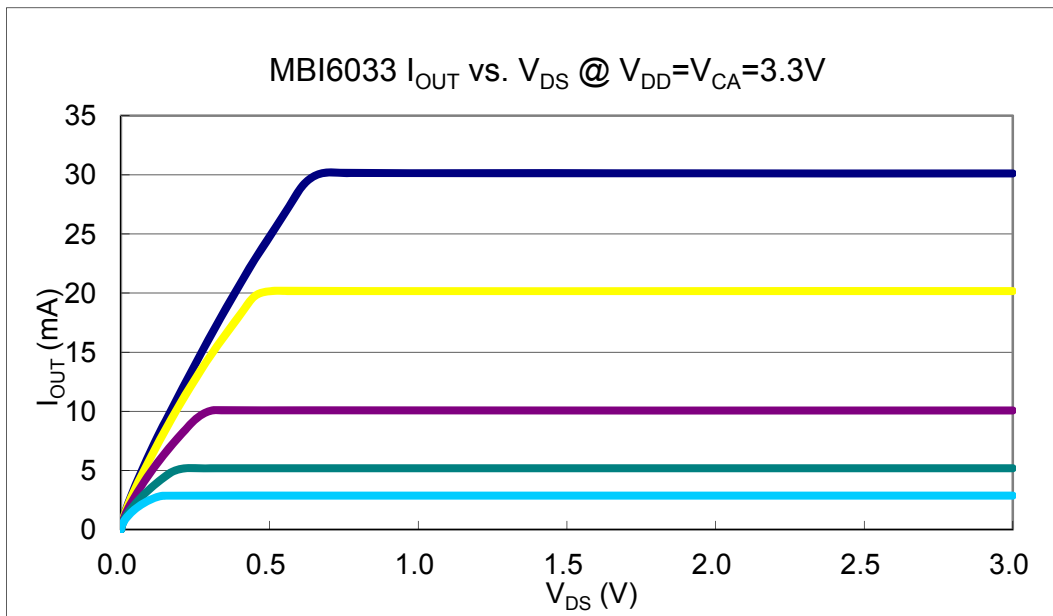
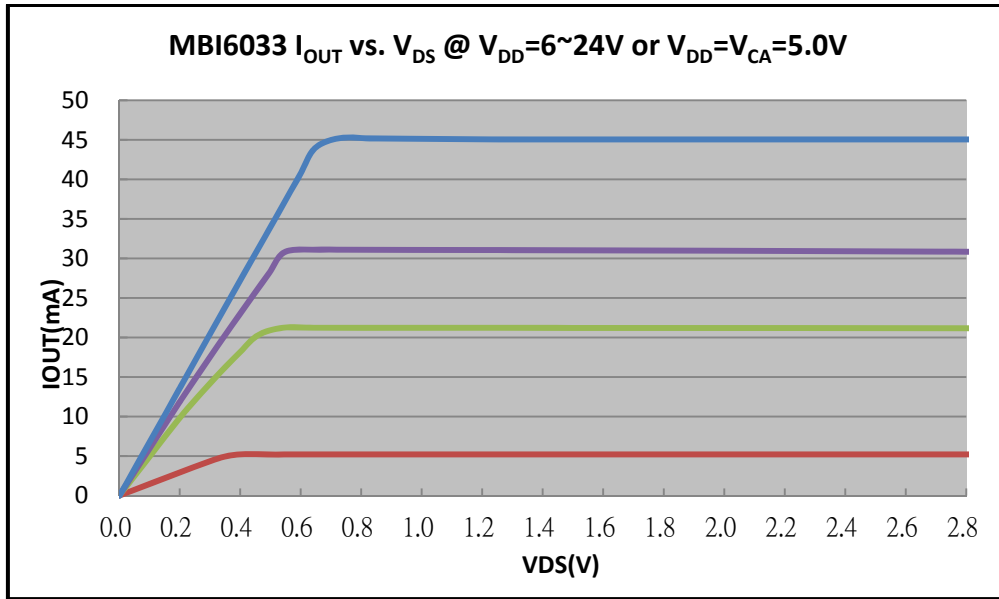

Setting the Output Current

The output current of each channel (I_{OUT}) is set by an external resistor, R_{ext} . The relationship between I_{OUT} and R_{ext} is shown in the following figure.

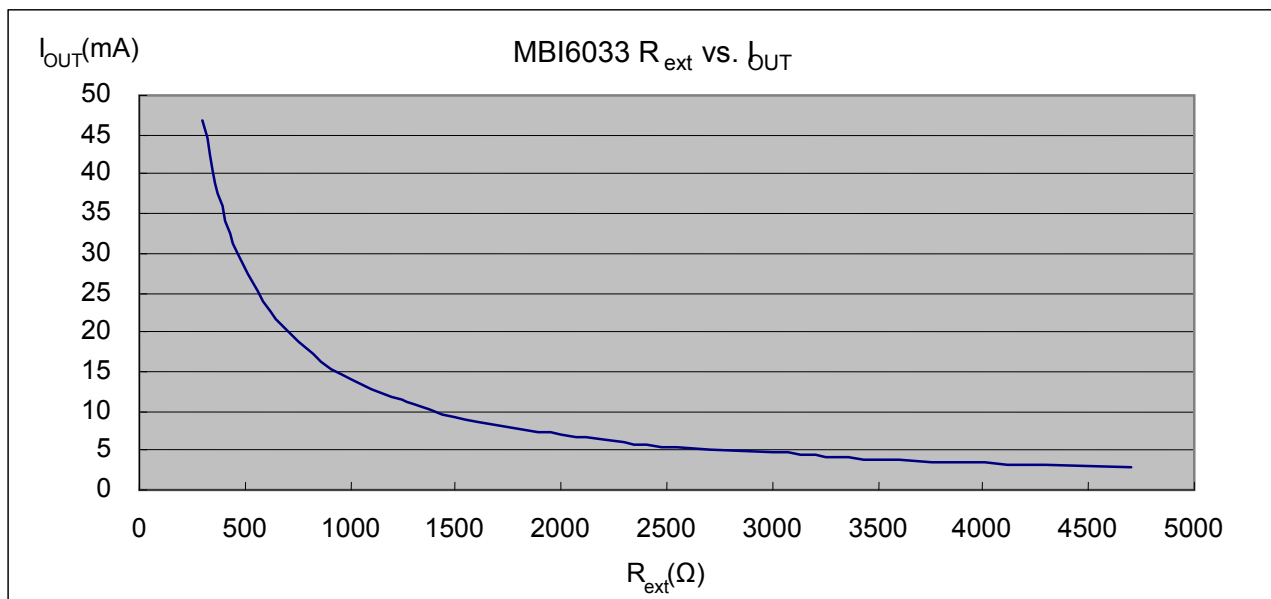

The output current of each channel (I_{OUT}) is set by an external resistor, R_{ext} . When output channels are turned on, V_{REXT} is around 0.61V. The relationship between I_{OUT} and R_{ext} is shown in the following figure.

Also, the output current can be calculated from the equation:

$$I_{OUTA} = (V_{REXT} / R_{ext}) \times 23 \times CG_A / 127$$

$$I_{OUTB} = (V_{REXT} / R_{ext}) \times 23 \times CG_B / 127$$

$$I_{OUTC} = (V_{REXT} / R_{ext}) \times 23 \times CG_C / 127$$

Package Power Dissipation (P_D)

The maximum power dissipation, $P_D(max)=(T_{j,max}-T_a)/R_{th(j-a)}$, decreases as the ambient temperature increases.

The power dissipation (P_D) is calculated by the equation:

$$P_D=(V_{DD} \times I_{DD})+(I_{OUTA} \times V_{DSA})+(I_{OUTB} \times V_{DSB})+(I_{OUTC} \times V_{DSC})$$

Please refer to the following figure to design within the safe operation area.

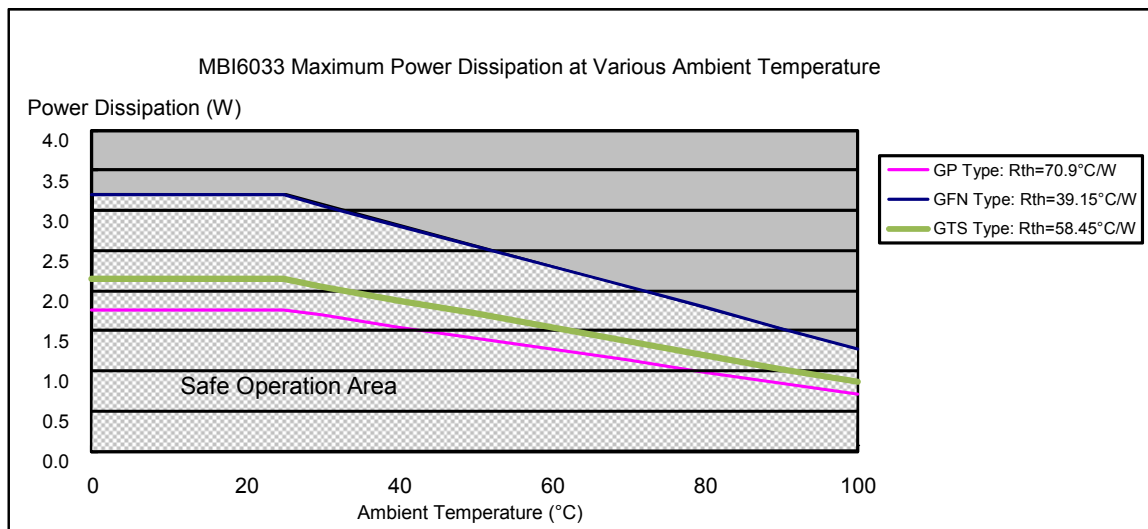

Load Supply Voltage (V_{LED})

The design of V_{LED} should fulfill two targets:

- 1. Less power consumption and heat
- 2. Sufficiently headroom for the LED and driver IC to operate in the constant-current region.

From the figure below, $V_{DS} = V_{LED} - V_F$, which V_{LED} is the supply voltage of LED. $P_{D(act)}$ will be greater than $P_{D(max)}$, if V_{DS} drops too much voltage on the driver. In this case, it is recommended to use the lowest possible supply voltage or to set an external resistor to reduce the by V_{DROP} .

$$V_{DS} = (V_{LED} - V_F) - V_{DROP}$$

Please refer to the following figure for the application of the resistor.

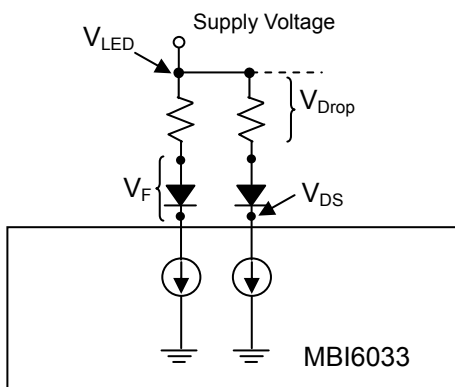

Switching Noise Reduction

The output ports of LED drivers are frequently switching in typical applications. This behavior usually causes switching noise due to the parasitic inductance on PCB. To eliminate switching noise, please refer to “Application Note for 8-bit and 16-bit LED Drivers-Overshoot”.

Soldering Process of "Pb-free & Green" Package Plating*

Macroblock has defined "Pb-Free & Green" to mean semiconductor products that are compatible with the current RoHS requirements and selected 100% pure tin (Sn) to provide forward and backward compatibility with both the current industry-standard SnPb-based soldering processes and higher-temperature Pb-free processes. Pure tin is widely accepted by customers and suppliers of electronic devices in Europe, Asia and the US as the lead-free surface finish of choice to replace tin-lead. Also, it is backward compatible to reflow processes which adopt tin/lead (SnPb) solder paste. Please refer to JEDEC J-STD-020C for temperature setting. However, in the whole Pb-free soldering processes and materials, 100% pure tin (Sn) will all require from 245 °C to 260 °C for proper soldering on boards, referring to JEDEC J-STD-020C as shown below.

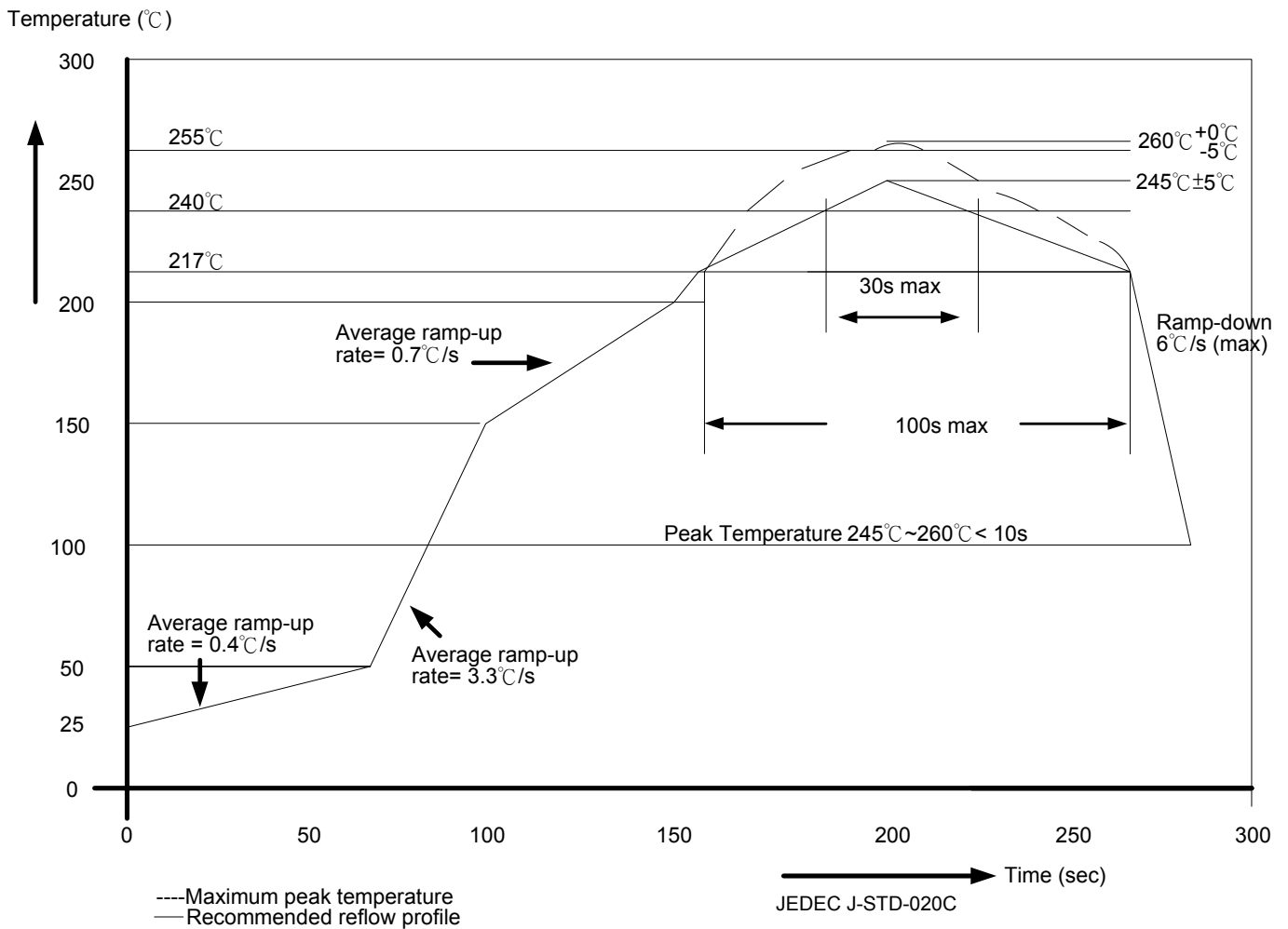

Package Thickness	Volume mm ³ <350	Volume mm ³ 350-2000	Volume mm ³ ≥2000
<1.6mm	260 +0 °C	260 +0 °C	260 +0 °C
1.6mm – 2.5mm	260 +0 °C	250 +0 °C	245 +0 °C
≥2.5mm	250 +0 °C	245 +0 °C	245 +0 °C

*For details, please refer to Macroblock's "Policy on Pb-free & Green Package".

Package Outline

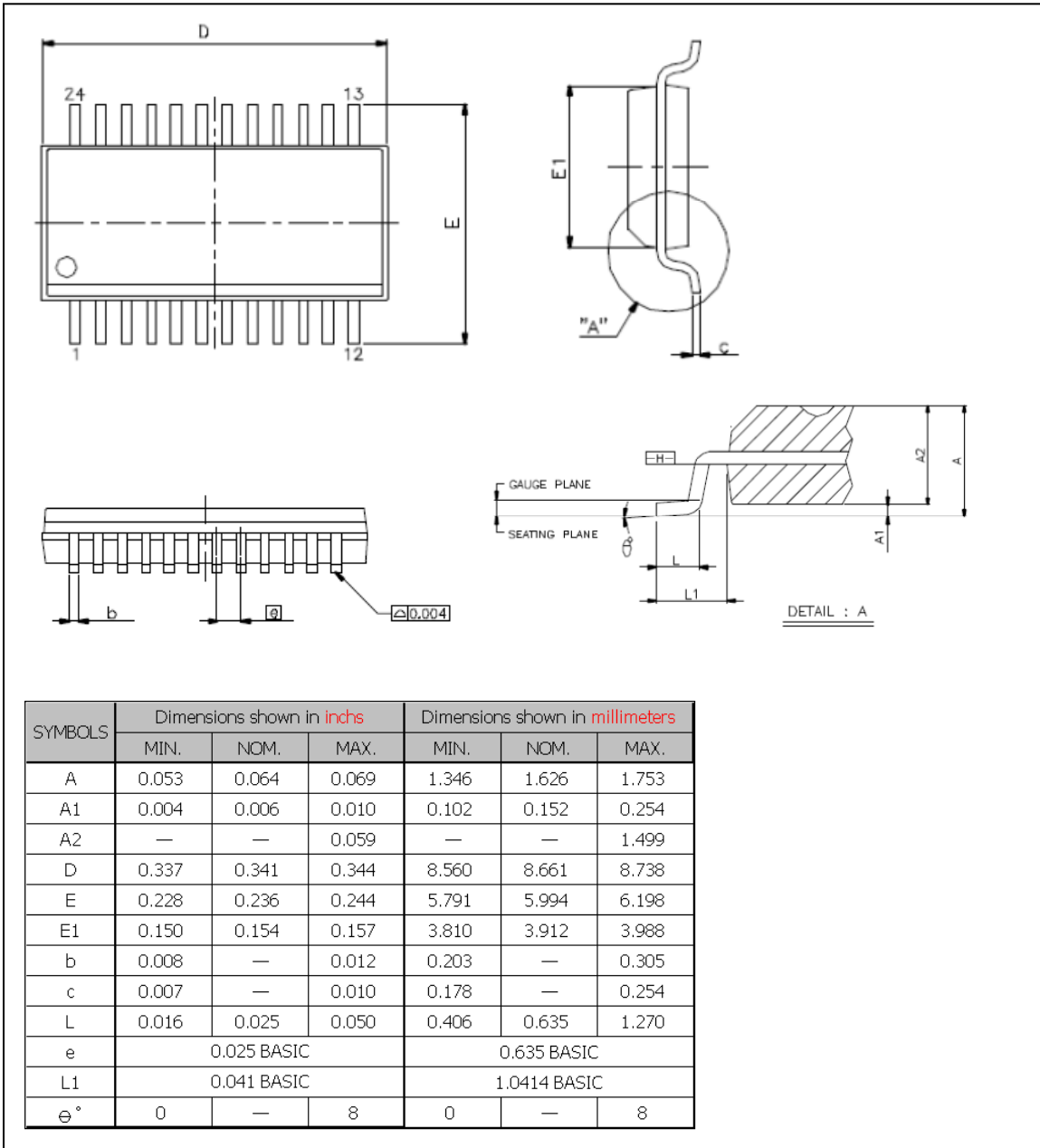

MBI6033GP Outline Drawing

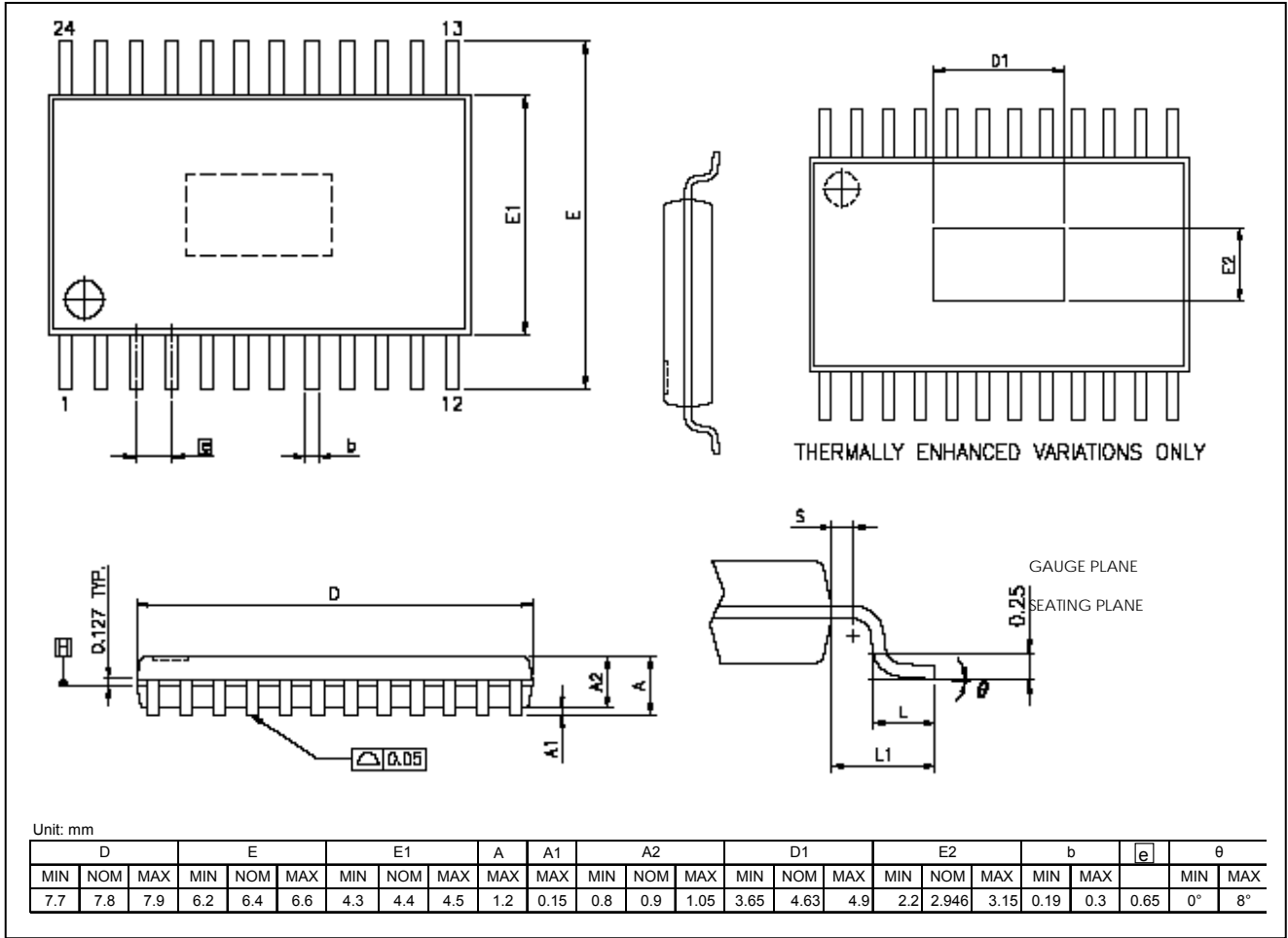

MBI6033GTS Outline Drawing

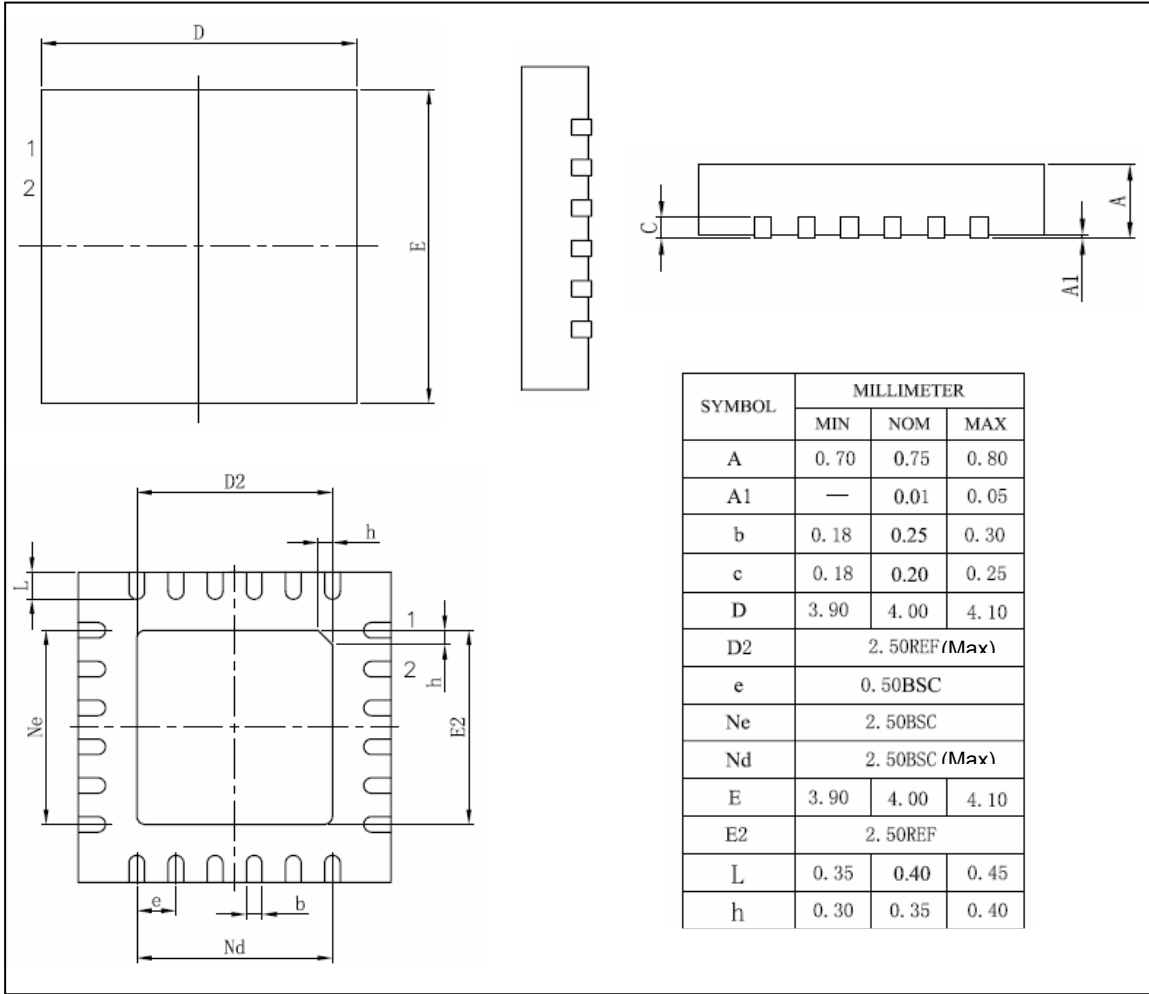

MBI6033GFN Outline Drawing

Note 1: The unit for the outline drawing is mm.

Note 2: Please use the maximum dimensions for the thermal pad layout. To avoid the short circuit risk, the vias or circuit traces shall not pass through the maximum area of thermal pad.

Product Top Mark Information

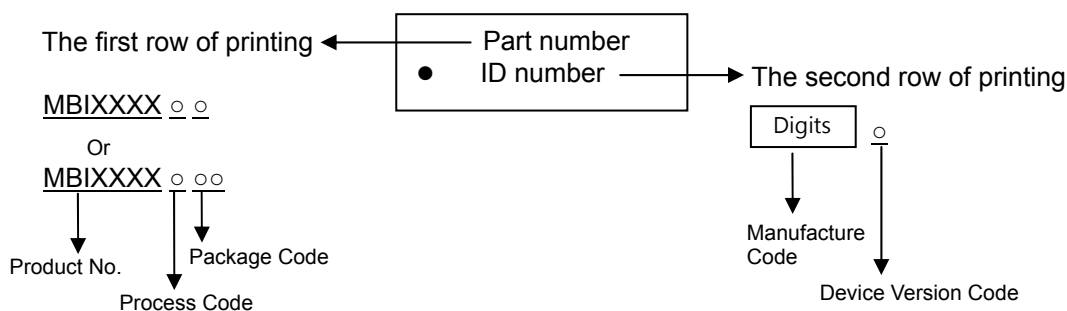

Product Revision History

Datasheet version	Device version code
V1.00	A

Product Ordering Information

Product Ordering Number*	RoHS-Compliant Package Type	Weight (g)
MBI6033GP-A	SSOP24L-150-0.64	0.11
MBI6033GTS-A	TSSOP24-173 -0.65	0.0967
MBI6033GFN-A	QFN24L-4*4-0.5	0.0379

*Please place your order with the “**product ordering number**” information on your purchase order (PO).

Disclaimer

Macroblock reserves the right to make changes, corrections, modifications, and improvements to their products and documents or discontinue any product or service. Customers are advised to consult their sales representative for the latest product information before ordering. All products are sold subject to the terms and conditions supplied at the time of order acknowledgement, including those pertaining to warranty, patent infringement, and limitation of liability.

Macroblock's products are not designed to be used as components in device intended to support or sustain life or in military applications. Use of Macroblock's products in components intended for surgical implant into the body, or other applications in which failure of Macroblock's products could create a situation where personal death or injury may occur, is not authorized without the express written approval of the Managing Director of Macroblock.

Macroblock will not be held liable for any damages or claims resulting from the use of its products in medical and military applications.

Related technologies applied to the product are protected by patents. All text, images, logos and information contained on this document is the intellectual property of Macroblock. Unauthorized reproduction, duplication, extraction, use or disclosure of the above mentioned intellectual property will be deemed as infringement.