



2A Synchronous Buck Li-ion Charger

General Description

The LP28300 is a 2A Li-Ion battery charger. It utilizes a 500KHz synchronous buck converter topology to reduce power dissipation during charging. Low power dissipation, an internal MOSFET allow a physically small charger that can be embedded in a wide range of handheld applications. The LP28300 includes complete charge termination circuitry, automatic recharge and a $\pm 1\%$ 4.2V / 8.4V / 12.6V float voltage.

Battery charge current, charge timeout and end-of-charge indication parameters are set with external components. Additional features include shorted cell detection; temperature qualified charging and overvoltage protection. The LP28300 is available in a low profile ESOP8 and package.

Order Information

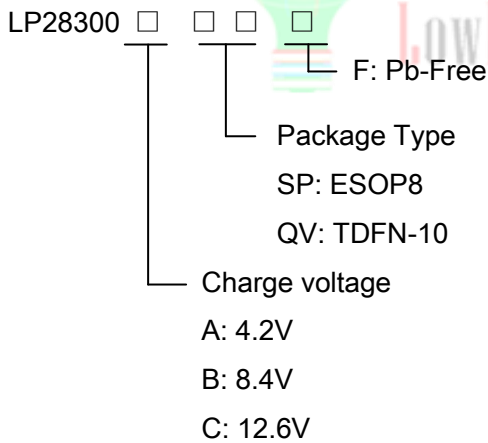

Applications

- ✧ Portable Media Players
- ✧ Cellular and Smart mobile phone
- ✧ PDA/DSC
- ✧ Handheld Battery-Powered Devices
- ✧ Handheld Computers
- ✧ Charging Docks and Cradles

Features

- ◆ Input voltage range 4V~18V
- ◆ Dynamic input current allocation for maximum charging rate
- ◆ 2.0A Maximum Charge Current
- ◆ No External MOSFETs and Blocking Diode Required
- ◆ Efficiency up to 90%
- ◆ Constant-Current/Constant-Voltage Operation with Thermal Regulation to Maximize Charge Rate Without Risk of Overheating
- ◆ Optional Battery Temperature Monitoring Before and During Charge Automatic Sleep Mode for Low-Power
- ◆ Over Current Protection
- ◆ Consumption Available in ESOP8
- ◆ RoHS Compliant and 100% Lead (Pb)-Free

Typical Application Circuit

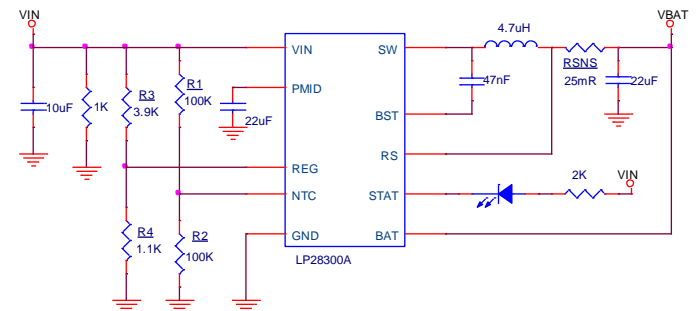

Marking Information

Device	Marking	Package	Shipping
LP28300ASPF	LPS LP28300A YWX	ESOP8 TDFN-10	2.5K/REEL 3K/REEL
LP28300BSPF	LPS LP28300B YWX	ESOP8 TDFN-10	2.5K/REEL 3K/REEL
LP28300CSPF	LPS LP28300C YWX	ESOP8 TDFN-10	2.5K/REEL 3K/REEL

Y: Year code. W: Week code. X: Batch numbers.



Functional Pin Description

Package Type	Pin Configurations
ESOP8 / TDFN-10	

Pin Description

Pin		Name	Description
ESOP8	TDFN-10		
SW	1	4	Switch pin. Connect to external inductor.
BST	2	8	Internal charge pump boost pin.
STAT	3	7	Open-Drain Charge Status Output. When the battery is charging, this pin is pulled low by an internal N-channel MOSFET. When the LP28300 detects an under voltage lockout condition, STAT is forced high impedance.
NTC	4	6	NTC (Negative Temperature Coefficient) Thermistor Input. This pin senses the temperature of the battery pack and stops the charger when the temperature is out of range. Connect to GND for disabling this function.
BAT	5	9	Battery pin.
RS	6	10	Detecting pin of charge current.
REG	7	1	Input voltage feedback for the input voltage regulation loop. Connect to tap of an external resistor divider from VIN to GND to program the input voltage regulation. Once the voltage at REG pin drops to the inner threshold, the charge current is reduced to maintain the input voltage at the regulation value.
VIN	8	2	Positive Supply Voltage Input. Decouple with a 10µF or larger surface mounted ceramic capacitor.
GND	Pad	5,11	Ground.
PMID		3	Power MOS input pin. Connect a 22uF Capacitor to ground.



Absolute Maximum Ratings ^{Note 1}

◇ VIN /PMID /BST/NTC to GND -----	24V
◇ REG Voltage to GND -----	6.5V
◇ BAT Pin to GND -----	20V
◇ Maximum Junction Temperature -----	150°C
◇ Operating Ambient Temperature Range (T _A) -----	-40°C to 85°C
◇ Storage Temperature -----	-45°C to 165°C
◇ Maximum Soldering Temperature (at leads, 10 sec) -----	260°C

Note 1. Stresses beyond those listed under “Absolute Maximum Ratings” may cause permanent damage to the device. These are stress ratings only, and functional operation of the device at these or any other conditions beyond those indicated in the operational sections of the specifications is not implied. Exposure to absolute maximum rating conditions for extended periods may affect device reliability.

Thermal Information

◇ Maximum Power Dissipation (ESOP8, P _D , T _A =25°C) -----	2W
◇ Thermal Resistance (ESOP8, θ _{JA}) -----	50°C/W
◇ Maximum Power Dissipation (TDFN-10, P _D , T _A =25°C) -----	1.5W
◇ Thermal Resistance (TDFN-10, θ _{JA}) -----	65°C/W

ESD Susceptibility

◇ HBM(Human Body Mode) -----	2KV
◇ MM(Machine Mode) -----	200V



Electrical Characteristics

($T_A=25^\circ\text{C}$, $V_{IN} = 5\text{V}$, unless otherwise noted.)

Symbol	Parameter	Condition	Min	Typ	Max	Units
V_{IN}	Adapter/USB Voltage Range		4		18	V
I_{CC}	Input Supply Current	Standby Mode (Charge Terminated)		1		mA
V_{FLOAT}	Regulated Output (Float) Voltage	LP28300A	4.158	4.2	4.242	V
		LP28300B		8.4		V
		LP28300C		12.6		V
V_{RS}	Program Charging Current (For RS to BAT)	$V_{TRIKL} < V_{BAT} < V_{FLOAT}$		50		mV
I_{BAT}	BAT Pin Current	$R_{SNS}=50\text{m}\Omega$, Current Mode		1000		mA
		$R_{SNS}=25\text{m}\Omega$, Current Mode		2000		mA
		Standby Mode		4		μA
I_{TRIKL}	Trickle Charge Current	$V_{BAT} < V_{TRIKL}$, $R_{SNS}=50\text{m}\Omega$		100		mA
		$V_{BAT} < 2.3\text{V}$		20		mA
V_{TRIKL}	Trickle Charge Threshold Voltage	$R_{SNS}=50\text{m}\Omega$, V_{BAT} Rising		2.8		V
V_{TRHYS}	Trickle Charge Hysteresis Voltage	$R_{SNS}=50\text{m}\Omega$		100		mV
V_{REG}	Input voltage regulation reference			1		V
V_{STAT}	STAT Pin Output Low Voltage	$I_{STAT}=5\text{mA}$			0.5	V
I_{STAT}	STAT Pin Weak Pull-Down Current	$V_{STAT}=5\text{V}$			5	μA
ΔV_{RECHRG}	Recharge Battery Threshold Voltage	$V_{FLOAT}-V_{RECHRG}$		150		mV
T_{LIM}	Junction Temperature in Constant Temperature Mode			150		$^\circ\text{C}$
I_{TERM}	C/10 Terminal Current	$R_{SNS}=50\text{m}\Omega$		100		mA
UVLO	Under Voltage Lockout of V_{IN}	V_{IN} rising		4		V
		V_{IN} falling		3.8		V
V_{NTC-L}	low Temperature Protection Threshold Voltage	Battery Temperature falling		70		$\%V_{IN}$
V_{NTC-H}	High Temperature Protection Threshold Voltage	Battery Temperature rising		30		$\%V_{IN}$
F_{OSC}	Frequency			500		KHz



Typical Operating Characteristics

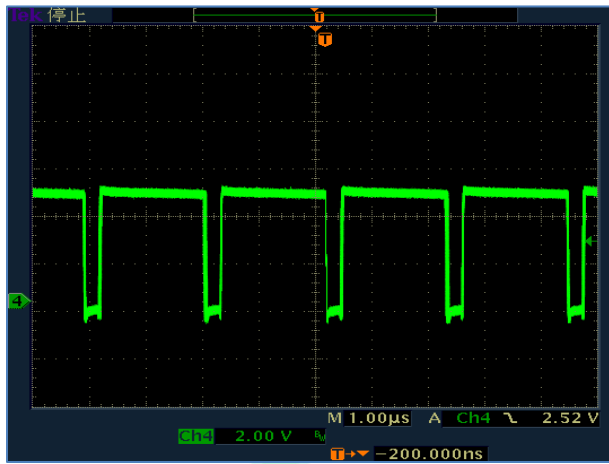
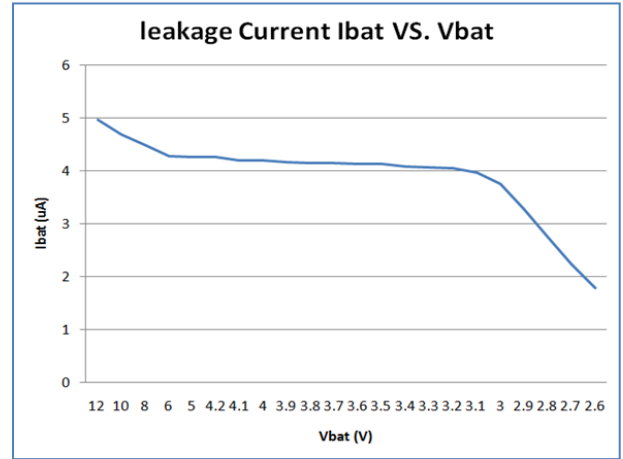
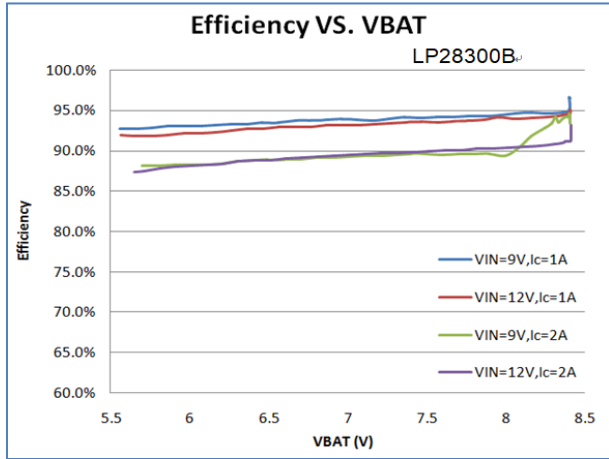

LP28300A, I_{BAT}=2A, CH4=V_{SW}, V_{IN}=5V

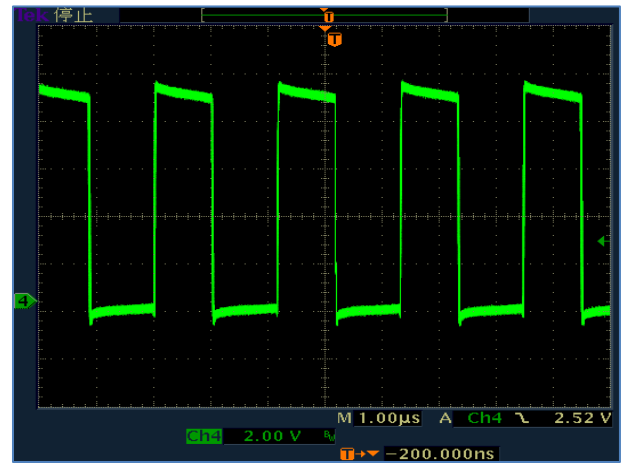

LP28300A, I_{BAT}=2A, CH4=V_{SW}, V_{IN}=9V

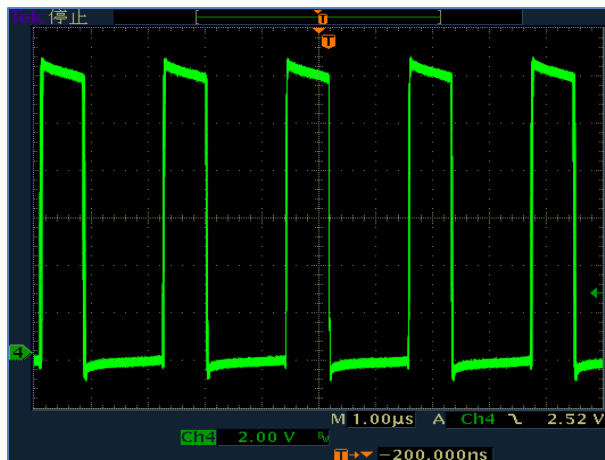

LP28300A, I_{BAT}=2A, CH4=V_{SW}, V_{IN}=12V



Application Information

LP28300 is a wide range $V_{IN}(4V-18V)$, 2A 1/2/3-cells asynchronous boost Li-Ion battery charger integrates 500KHz switching frequency and full protection functions. The charge current up to 2A can be programmed by using the external resistor for different portable applications and indicates the charger current information simultaneous.

In constant current mode, the charge current is set by the external sense resistor R_{SNS} and an internal 50mV reference;

$$I_{BAT} = V_{RS} / R_{SNS} = 50mV / R_{SNS}$$

When the battery voltage approaches the programmed float voltage, the charge current will start to decrease. When the current drops to 10% of the full-scale charge current, an internal comparator turns off charging is terminated

Input Source Qualification

After R_{EGN} amplifier powers up, the LP28300 checks the current capability of the input source. The input source has to meet the $V_{REG} > 1V$ to enable the chip.

Automatic Recharge

Once the charge cycle is terminated, the LP28300 continuously monitors the voltage on the BAT pin using a comparator with a 1.8ms filter time ($t_{RECHARGE}$). A charge cycle restarts when the battery voltage falls below 4.05V (which corresponds to approximately 80% to 90% battery capacity). This ensures that the battery is kept at or near a fully charged condition and eliminates the need for periodic charge cycle initiations.

Battery Temperature Detection

The LP28300 continuously monitors temperature by measuring the voltage between the NTC and GND pins. A negative or a positive temperature coefficient thermistor (NTC, PTC) and an external voltage divider typically develop this voltage. The LP28300 compares this voltage against its internal V_{NTC-H} and V_{NTC-L} thresholds to determine if charging is allowed. The temperature sensing circuit is immune to any fluctuation in V_{IN} , since both the external voltage divider and the internal thresholds (V_{NTC-H} and V_{NTC-L}) are referenced to V_{IN} .

The resistor values of R_1 and R_2 are calculated by the following equations:

For NTC Thermistors:

$$R_1 = \frac{R_{TL}R_{TH}(K_2 - K_1)}{(R_{TL} - R_{TH})K_1K_2}$$

$$R_2 = \frac{R_{TL}R_{TH}(K_2 - K_1)}{R_{TL}(K_1 - K_1K_2) - R_{TH}(K_2 - K_1K_2)}$$

For PTC Thermistors:

$$R_1 = \frac{R_{TL}R_{TH}(K_2 - K_1)}{(R_{TH} - R_{TL})K_1K_2}$$

$$R_2 = \frac{R_{TL}R_{TH}(K_2 - K_1)}{R_{TH}(K_1 - K_1K_2) - R_{TL}(K_2 - K_1K_2)}$$

$K_{1(V_{NTC-H})} = 30\%$, $K_{2(V_{NTC-L})} = 70\%$.

Where R_{TL} is the low temperature resistance and R_{TH} is the high temperature resistance of thermistor, as specified by the thermistor manufacturer. R_1 or R_2 can be omitted if only one temperature (low or high) setting is required. Applying a voltage between the V_{NTC-H} and V_{NTC-L} thresholds to pin NTC disables the temperature-sensing feature.



Shutdown

The LP28300 can be shut down by pulling the NTC pin to VIN. When the NTC pin is released, the internal timer is reset and a new charge cycle starts.

Inductor Selection

A operating frequency was chosen for the buck switcher in order to minimize the size of the inductor. However, take care to use inductors with low core loss at this frequency. To calculate the inductor ripple current:

$$\Delta I_L = \frac{V_{BAT} - \frac{V_{BAT}^2}{V_{IN}}}{L \times f}$$

Charge Status Indicator (STAT)

The charge status output has two different states: strong pull-down (~5mA) and high impedance. The strong pull-down state indicates that the LP28300 is in a charge cycle. Once the charge cycle has terminated, the pin state is determined by under voltage lockout conditions. High impedance indicates that the charge cycle complete .

Layout Considerations

Switch rise and fall times are kept under 5ns for maximum efficiency. To minimize radiation, the SW pin and input bypass capacitor leads (between VIN and GND) should be kept as short as possible. A ground plane should be used under the switching circuitry to prevent inter plane coupling. The Exposed Pad must be connected to the ground plane for proper power dissipation. The other paths contain only DC and/or 500KHz tri-wave ripple current and are less critical. With the exception of the input and output filter capacitors (which should be connected to GND) all other components that return to ground should be connected to GND.



Packaging Information

ESOP8

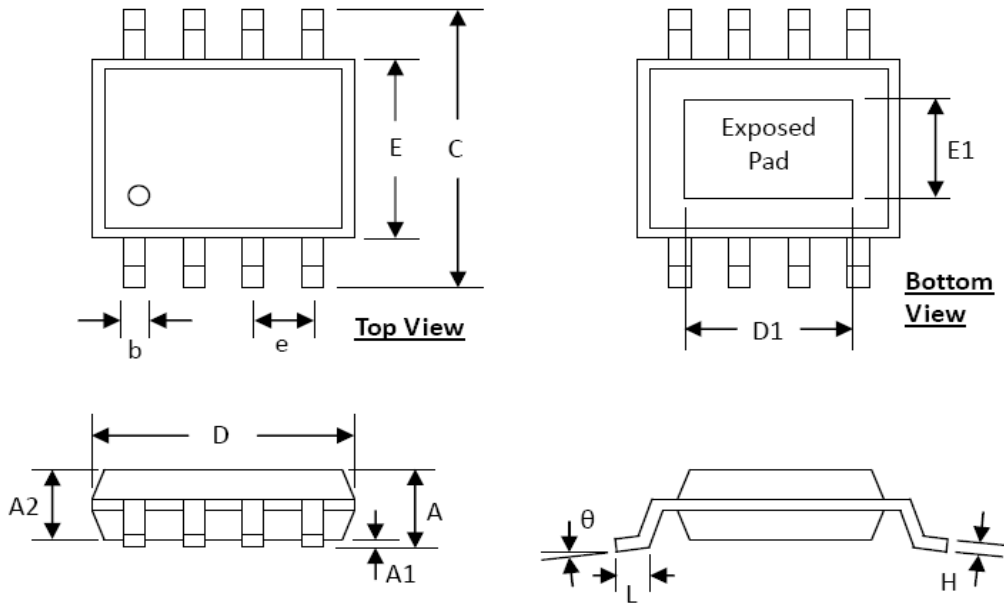

SYMBOLS	DIMENSION (MM)		DIMENSION (INCH)	
	MIN	MAX	MIN	MAX
A	1.30	1.70	0.051	0.067
A1	0.00	0.15	0.000	0.006
A2	1.25	1.52	0.049	0.060
b	0.33	0.51	0.013	0.020
C	5.80	6.20	0.228	0.244
D	4.80	5.00	0.189	0.197
D1	3.15	3.45	0.124	0.136
E	3.80	4.00	0.150	0.157
E1	2.26	2.56	0.089	0.101
e	1.27 BSC		0.050 BSC	
H	0.19	0.25	0.0075	0.0098
L	0.41	1.27	0.016	0.050
θ	0°	8°	0°	8°



TDFN-10

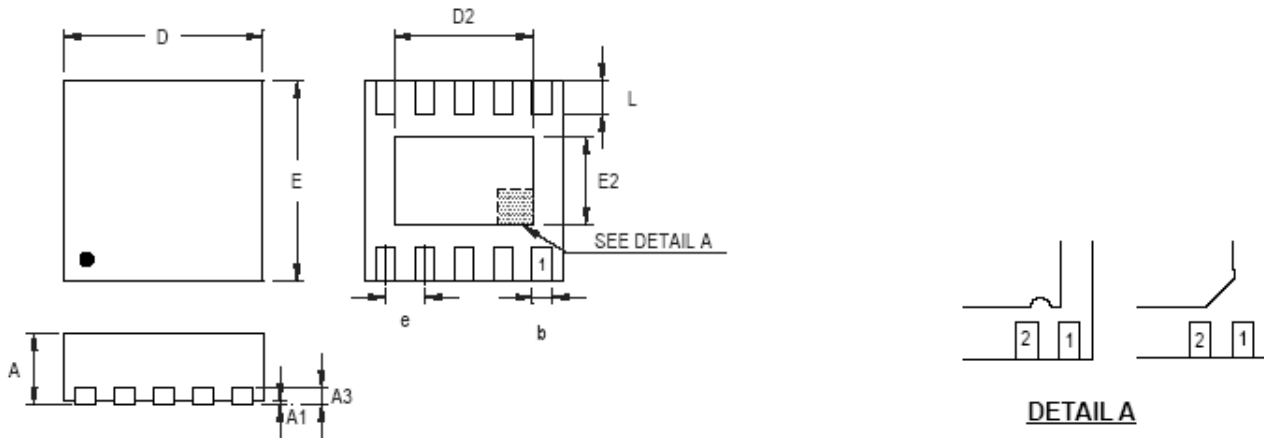

Pin #1 ID and Tie Bar Mark Options

Note : The configuration of the Pin #1 identifier is optional, but must be located within the zone indicated.

Symbol	Dimensions In Millimeters		Dimensions In Inches	
	Min	Max	Min	Max
A	0.700	0.800	0.028	0.031
A1	0.000	0.050	0.000	0.002
A3	0.175	0.250	0.007	0.010
b	0.180	0.300	0.007	0.012
D	2.950	3.050	0.116	0.120
D2	2.300	2.650	0.091	0.104
E	2.950	3.050	0.116	0.120
E2	1.500	1.750	0.059	0.069
e	0.500		0.020	
L	0.350	0.450	0.014	0.018

W-Type 10L DFN 3x3 Package