

## Super-Small Package PWM Control Step-up Switching Regulator

### ■ General Description

The LN2266 is a compact, high efficiency, and low voltage step-up DC/DC converter with an Adaptive Current Mode PWM control loop, includes an error amplifier, ramp generator, comparator, switch pass element and driver in which providing a stable and high efficient operation over a wide range of load currents. It operates in stable waveforms without external compensation.

The low start-up input voltage below 0.9V makes LN2266 suitable for 1 to 4 battery cells applications of providing up to 1100mA output current. Besides, the 17 $\mu$ A low quiescent current together with high efficiency maintains long battery lifetime. The output voltage is set with two external resistors. Both internal 2.5A switch and driver for driving external power devices (NMOS or NPN) are provided.

### ■ Package

- SOT23-6L
- SOT89-5L

### ■ Typical Application Circuit

### ■ Features

- 0.9V ( $I_{out}=1mA$ ) Low start-up input voltage
- 1000kHz fixed switching frequency
- 90% efficiency
- High supply capability to deliver 3.3V 300mA with 1 alkaline cell or deliver 5V 1100mA with 1 Li-ion Cell
- 17 $\mu$ A quiescent (switch-off) supply current
- 0.01 $\mu$ A shutdown mode supply current
- Providing flexibility for using internal and external power switches
- Output voltage: settable to between 2.0V to 5.2V ,accuracy of 2%

### ■ Applications

- MP3
- PDA
- DSC
- LCD panel
- RF-Tags
- Portable instrument
- Wireless equipment

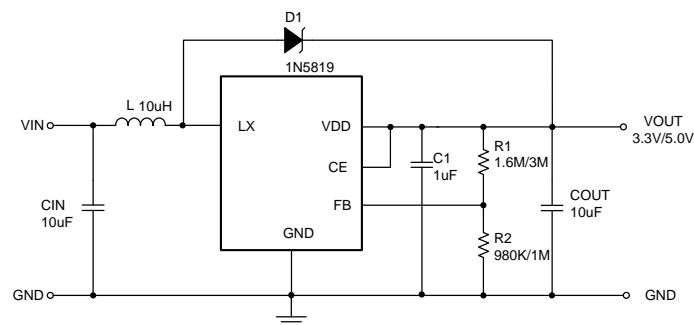

**Circuit 1. LN2266 Typical Application for Portable Instruments**

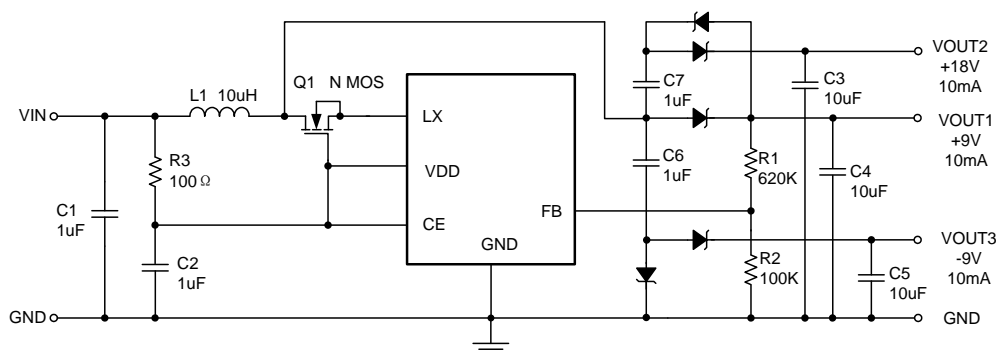

**Circuit 2. LN2266 for multi-output Application**

### Ordering Information

LN2266P①②③④⑤

| Designator | Symbol | Description            | Designator | Symbol | Description                  |
|------------|--------|------------------------|------------|--------|------------------------------|
| ①          | A      | CE with EXT            | ③          | M      | SOT23-6L                     |
|            | B      | CE without EXT         |            | P      | SOT89-5L                     |
| ②          | 1      | Reference accuracy:±1% | ④          | R      | Embossed Tape :Standard Feed |
|            | 2      | Reference accuracy:±2% |            | L      | Embossed Tape : Reverse Feed |
|            | 4      | Reference accuracy:±4% | ⑤          | G      | Green epoxy molding compound |

### Pin Configuration

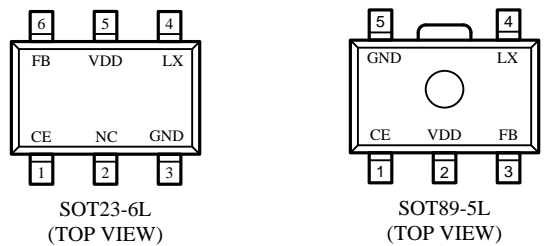

### Pin Assignment

| Pin Number |          | Pin Name | Function                           |
|------------|----------|----------|------------------------------------|
| SOT23-6L   | SOT89-5L |          |                                    |
| 1          | 1        | CE       | Chip enable                        |
| 2          | -        | NC       | Floating or connected to GND       |
| 3          | 5        | GND      | Ground                             |
| 4          | 4        | LX       | Pin for switching                  |
| 5          | 2        | VDD      | Input positive power pin of LN2266 |
| 6          | 3        | FB       | Feedback input pin                 |

### Marking Rule

- SOT23-6L, SOT89-5L

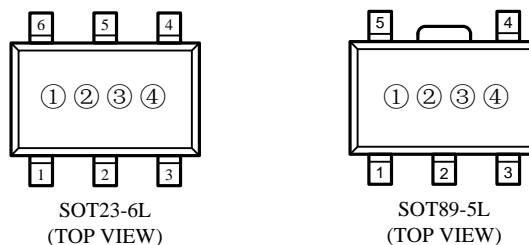

- ① Represents the product name

| Symbol | Product Name |
|--------|--------------|
| A      | LN2266P****  |

- ② Represents the type of regulator

| Symbol | A           | B              |
|--------|-------------|----------------|
| Type   | CE with EXT | CE without EXT |

③ Represents the accuracy of reference voltage

| Symbol | Reference Accuracy |
|--------|--------------------|
| 1      | 1%                 |
| 2      | 2%                 |
| 4      | 4%                 |

④ Represents the assembly lot No.

0-9, A-Z; 0-9, A-Z mirror writing, repeated (G, I, J, O, Q, W exception)

## ■ Function Block Diagram

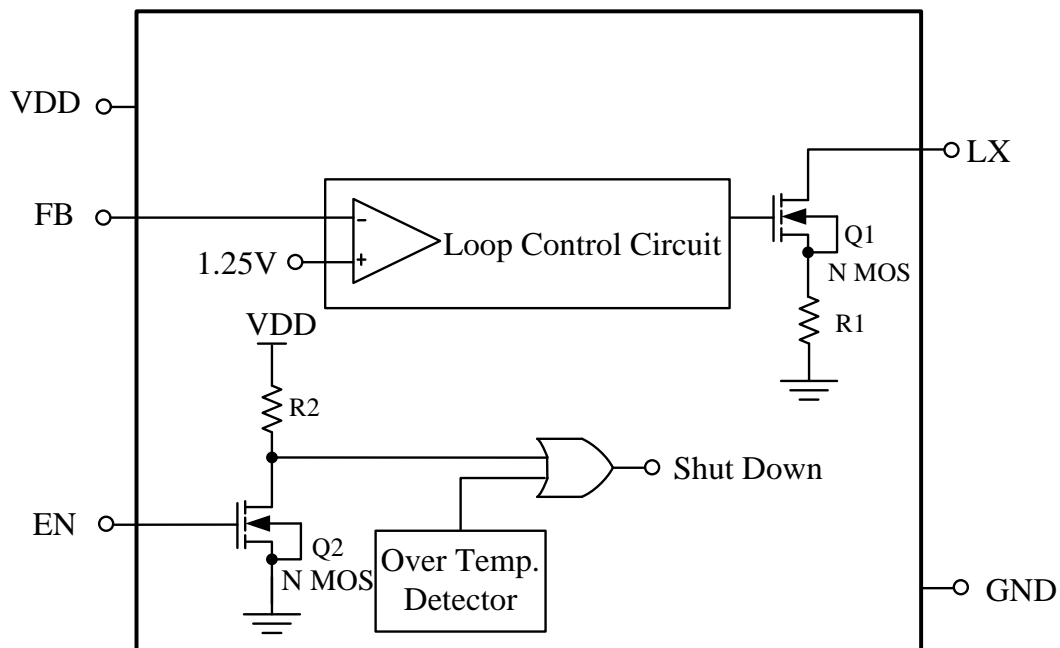

## ■ Absolute Maximum Ratings

| Parameter                     | Symbol    | Maximum Rating               | Unit |    |
|-------------------------------|-----------|------------------------------|------|----|
| Input voltage                 | $V_{DD}$  | $V_{SS}-0.3 \sim V_{SS}+5.5$ | V    |    |
| Output voltage                | $V_{OUT}$ | $V_{SS}-0.3 \sim V_{SS}+5.5$ |      |    |
|                               | $V_{LX}$  | $V_{SS}-0.3 \sim V_{SS}+5.5$ |      |    |
| LX pin Switch Current         | $I_{LX}$  | 2.5                          | A    |    |
| Power dissipation             | PD        | SOT23-6L                     | 150  | mW |
|                               |           | SOT89-5L                     | 500  |    |
| Operating ambient temperature | $T_{opr}$ | $-40 \sim +80$               | °C   |    |
| Storage ambient temperature   | $T_{stg}$ | $-40 \sim +125$              |      |    |

**Caution :** The absolute maximum ratings are rated values exceeding which the product could suffer physical damage. These values must therefore not be exceeded under any conditions.

**■ Electrical Characteristics**

 (VIN=1.5V, VDD=3.3V, I<sub>Load</sub>=0, Ta=25°C, unless otherwise noted)

| Item                                       | Symbol                  | Condition                                    | Min.  | Typ. | Max.  | Unit   |
|--|-------------------------|--|-------|------|-------|--------|
| Operation start voltage                    | V <sub>ST</sub>         | I <sub>OUT</sub> =1mA                        | -     | 0.9  | 1.00  | V      |
| VDD supply voltage                         | V <sub>DD</sub>         | VDD pin voltage                              | 2     | -    | 6     |        |
| Shut down current                          | I <sub>OFF</sub>        | CE=0, VIN=4.5V                               | -     | 0.01 | 1     | μA     |
| Switch-off Current                         | I <sub>switch-off</sub> | VIN=6V                                       | -     | 17   | 25    | μA     |
| Continuous Switching Current               | I <sub>switch</sub>     | VIN=CE=3.3V, VFB=GND                         | -     | 500  | -     | μA     |
| No load Current                            | I <sub>no-load</sub>    | VIN=1.5V, VOUT=3.3V                          | -     | 56   | -     | μA     |
| Feedback Reference Voltage                 | V <sub>ref</sub>        | Close Loop V <sub>dd</sub> =3.3V             | 1.225 | 1.25 | 1.275 | V      |
| Switching Frequency                        | F <sub>s</sub>          | V <sub>dd</sub> =3.3V                        | 800   | 1000 | 1250  | KHz    |
| Maximum Duty                               | D <sub>max</sub>        | V <sub>dd</sub> =3.3V                        | 70    | 75   | 80    | %      |
| LX on resistance                           | -                       | V <sub>dd</sub> =3.3V                        | -     | 0.18 | 0.25  | Ω      |
| Current Limit Setting                      | I <sub>limit</sub>      | V <sub>dd</sub> =3.3V                        | 2.3   | 2.5  | 2.7   | A      |
| EXT on resistance to VDD                   | -                       | V <sub>dd</sub> =3.3V                        | -     | 4    | 8.0   | Ω      |
| EXT on resistance to GND                   | -                       | V <sub>dd</sub> =3.3V                        | -     | 2.15 | 8.0   | Ω      |
| Line Regulation                            | ΔV <sub>line</sub>      | V <sub>in</sub> =3.5~6V, I <sub>L</sub> =1mA | -     | 0.25 | 5     | mV/V   |
| Load Regulation                            | ΔV <sub>load</sub>      | VIN=2.5V, I <sub>L</sub> =1~100mA            | -     | 0.5  | -     | mV/mA  |
| CE pin Trip level                          | -                       | VDD=3.3V                                     | 0.4   | 0.8  | 1.2   | V      |
| Temperature Stability for V <sub>out</sub> | T <sub>s</sub>          | -  | -     | 50   | -     | Ppm/°C |
| Thermal Shut down Hysterises               | ΔT <sub>sd</sub>        | -  | -     | 10   | -     | °C     |

## Typical Performance Characteristics

### 1. Efficiency vs. Output Current

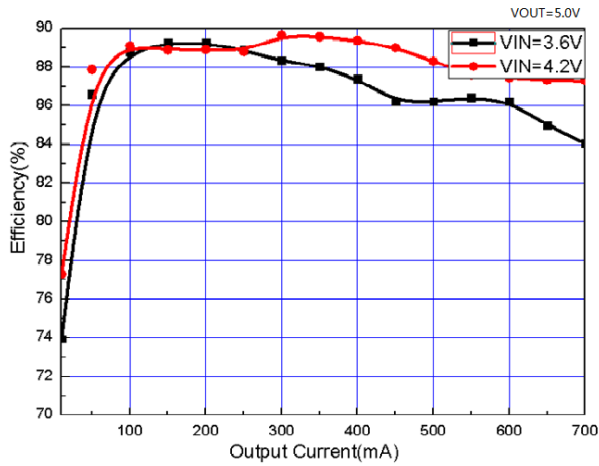

### 2. Supply Current vs. Input Voltage

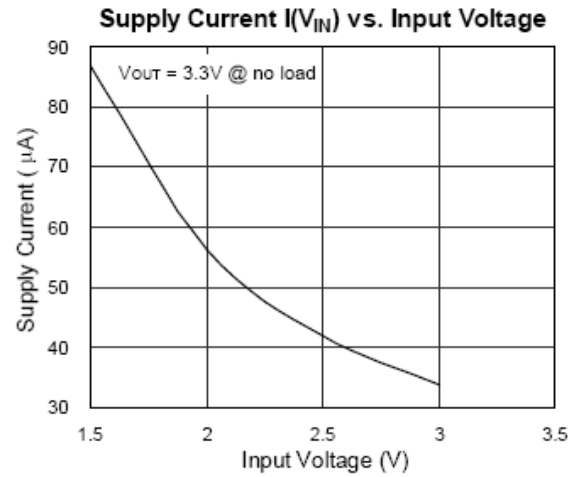

### 3. Switching Frequency vs. Vdd pin Voltage

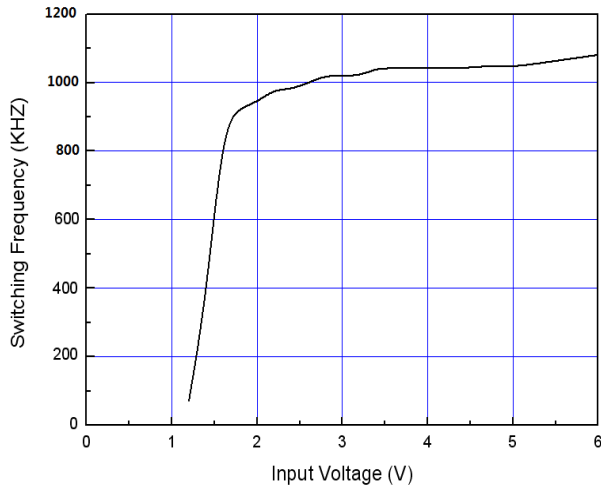

### 4. LX pin wave form & Output Ripple

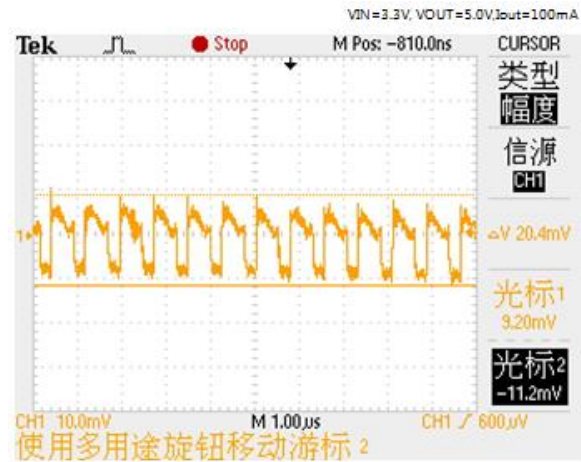

### 5. Transient Response

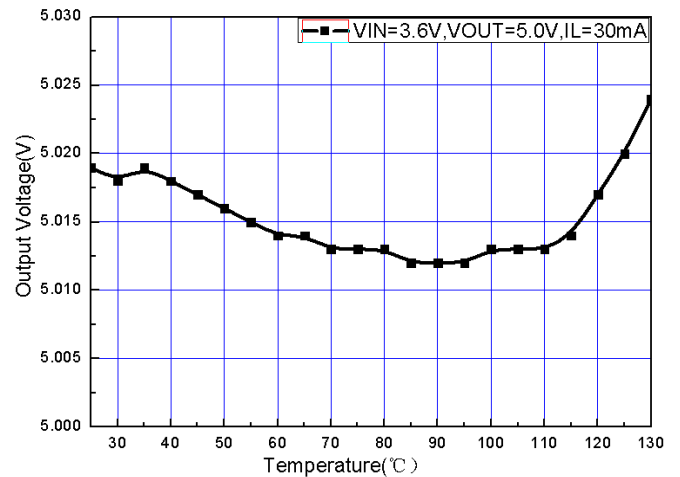
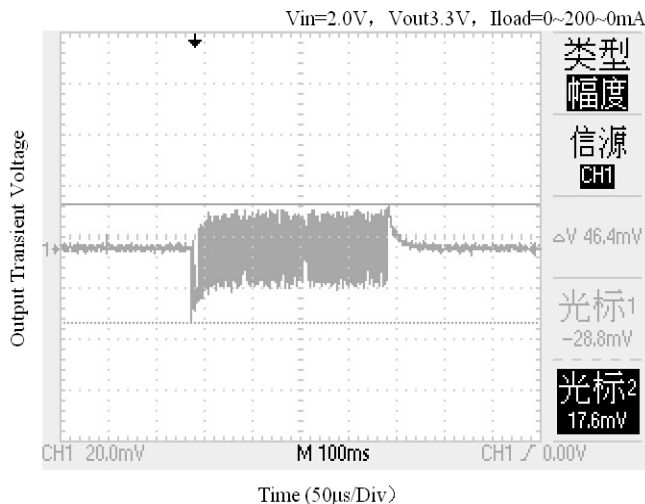

### 6. Output Voltage vs. Temperature

7. VIN VS The Max Output Current ( VOUT=5.0V)

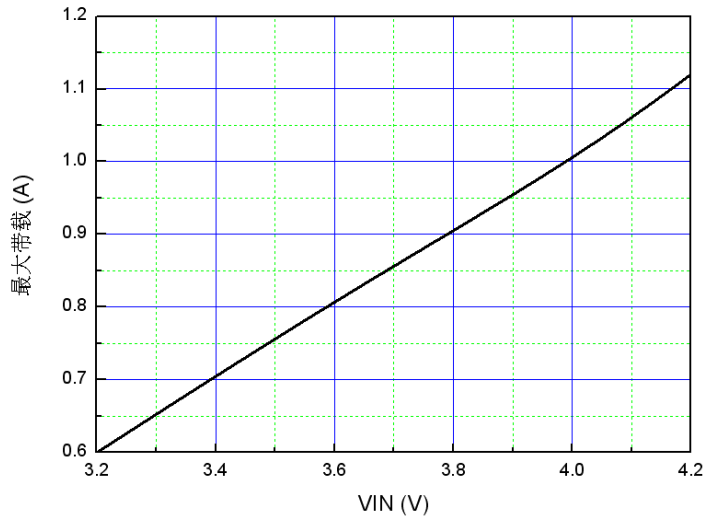

**Package Information**

- SOT23-6L

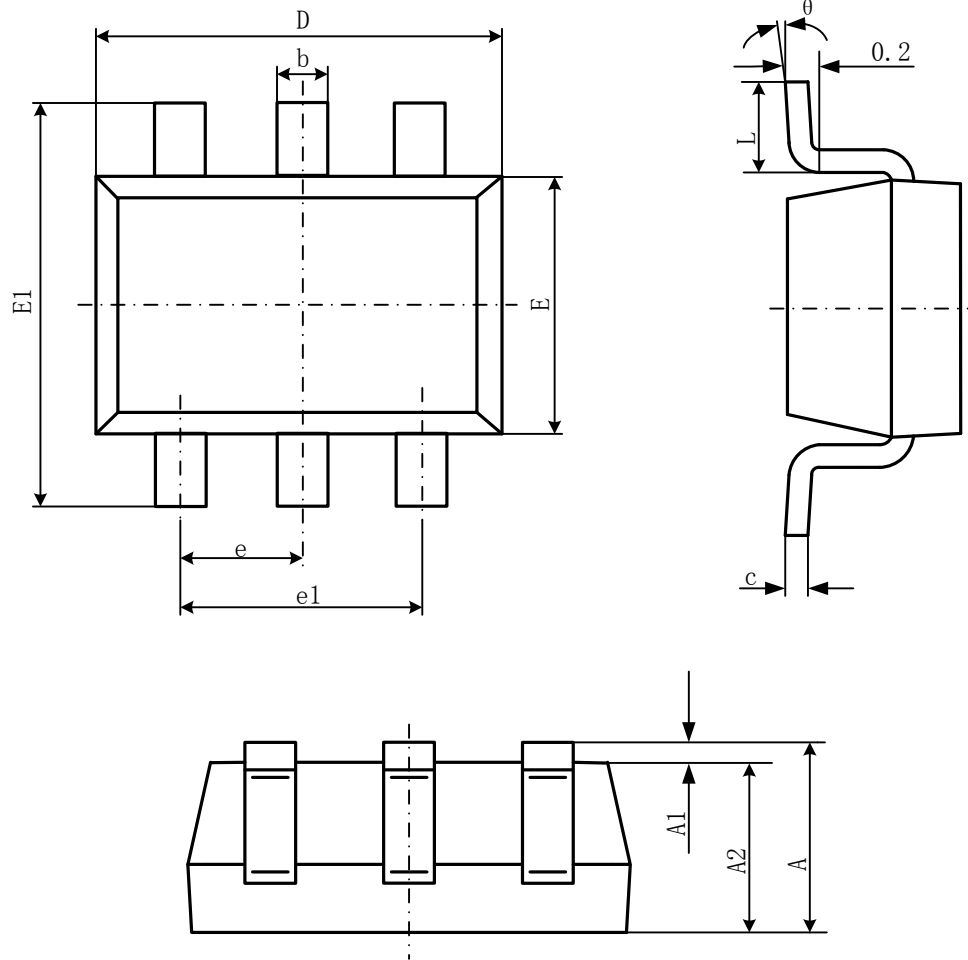

| Symbol | Dimensions In Millimeters |       | Dimensions In Inches |       |
|--------|---------------------------|-------|----------------------|-------|
|        | Min                       | Max   | Min                  | Max   |
| Z      | 1.050                     | 1.250 | 0.041                | 0.049 |
| A1     | 0.000                     | 0.100 | 0.000                | 0.004 |
| A2     | 1.050                     | 1.150 | 0.041                | 0.045 |
| b      | 0.300                     | 0.500 | 0.012                | 0.020 |
| c      | 0.100                     | 0.200 | 0.004                | 0.008 |
| D      | 2.820                     | 3.020 | 0.111                | 0.119 |
| E      | 1.500                     | 1.700 | 0.059                | 0.067 |
| E1     | 2.650                     | 2.950 | 0.104                | 0.116 |
| e      | 0.950(BSC)                |       | 0.037(BSC)           |       |
| e1     | 1.800                     | 2.000 | 0.071                | 0.079 |
| L      | 0.300                     | 0.600 | 0.012                | 0.024 |
| θ      | 0°                        | 8°    | 0°                   | 8°    |

## ● SOT-89-5L

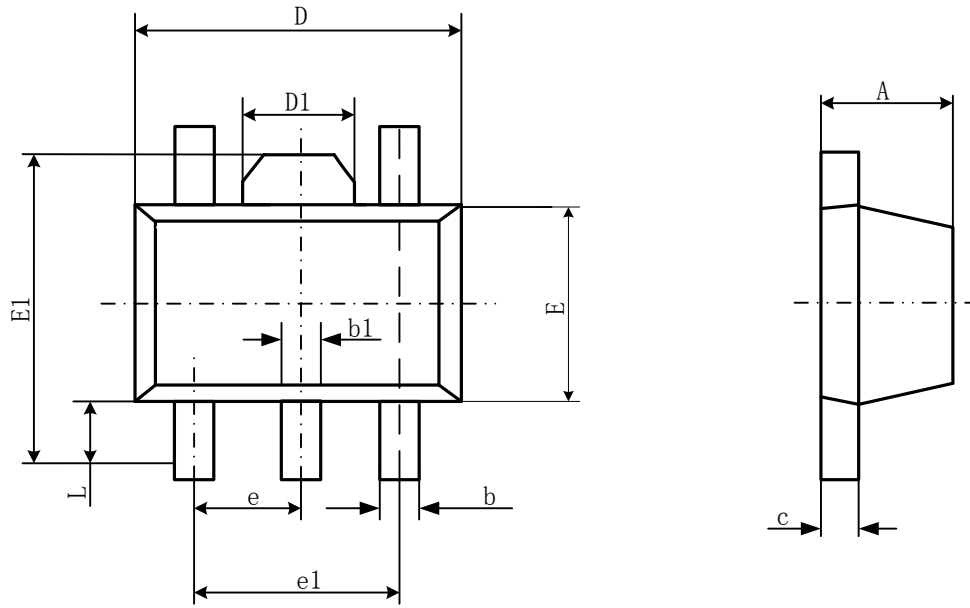

| Symbol | Dimensions In Millimeters |       | Dimensions In Inches |       |
|--------|---------------------------|-------|----------------------|-------|
|        | Min                       | Max   | Min                  | Max   |
| A      | 1.400                     | 1.600 | 0.055                | 0.063 |
| b      | 0.320                     | 0.520 | 0.013                | 0.020 |
| b1     | 0.360                     | 0.560 | 0.014                | 0.022 |
| c      | 0.350                     | 0.400 | 0.014                | 0.017 |
| D      | 4.400                     | 4.600 | 0.173                | 0.181 |
| D1     | 1.400                     | 1.800 | 0.055                | 0.071 |
| E      | 2.300                     | 2.600 | 0.091                | 0.102 |
| E1     | 3.940                     | 4.250 | 0.155                | 0.167 |
| e      | 1.500TYP                  |       | 0.060TYP             |       |
| e1     | 2.900                     | 3.100 | 0.114                | 0.122 |
| L      | 0.900                     | 1.100 | 0.035                | 0.043 |