

# SPECIFICATION FOR APPROVAL

## 承 認 書

Description : Piezoelectric Telephone Receiver  
Kingstate Part No. : **KPEG006**  
Customer's Model No. :  
Specification No. : **PKD-7246**  
Number Of The Edition : **1.1**

CUSTOMER'S APPROVED SIGNATURE		

志豐電子股份有限公司 KINGSTATE ELECTRONICS CORP.



Address: 10F, No. 69-11, Sec. 2, Chung Cheng E. Rd., Tamshui County, Taipei Hsien, Taiwan, R.O.C.

International sales dept.: TEL : 886-2-2809-5651 FAX:886-2-2809-7151

Domestic sales dept.: TEL : 886-2-2809-0668 FAX:886-2-28096748

[http : //www.kingstate.com.tw](http://www.kingstate.com.tw)

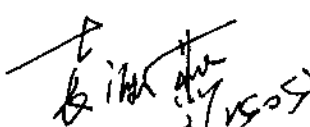
Approved by	Checked by	Issued by
	姚海平 3/25/05	Fei . 3/25/05

## A. SCOPE 範疇

This specification applies receiver, **KPEG006**

此規格書適用於受話器, **KPEG006**

## B. SPECIFICATION 規格

No.	Item	Symbol	Unit	Specification	Condition
1	Dimension 尺寸		mm	22.5 x 3.2	Refer to attached drawing in details
2	Impedance 阻抗		ohm	2000 ± 25%	At 1kHz
3	S.P.L. 音壓位準		dB	108 ± 3	At 1KHz 1.0V with IEC318 Coupler
4	Operating temp. 操作溫度			-30 ~ +85	
5	Storage temp. 儲存溫度			-40 ~ +95	
6	Electrostatic capacity 靜電容量		pF	90,000 ± 30%	At 120Hz/0.25V
7	Weight 重量		g	1.1	
8	Material 材質			ABS UL-94 1/16" HB High Heat ( Black )	
9	Environmental Protection Regulation 環保法規			ROHS	

**C. TYPICAL FREQUENCY RESPONSE CURVE 頻率響應曲線**

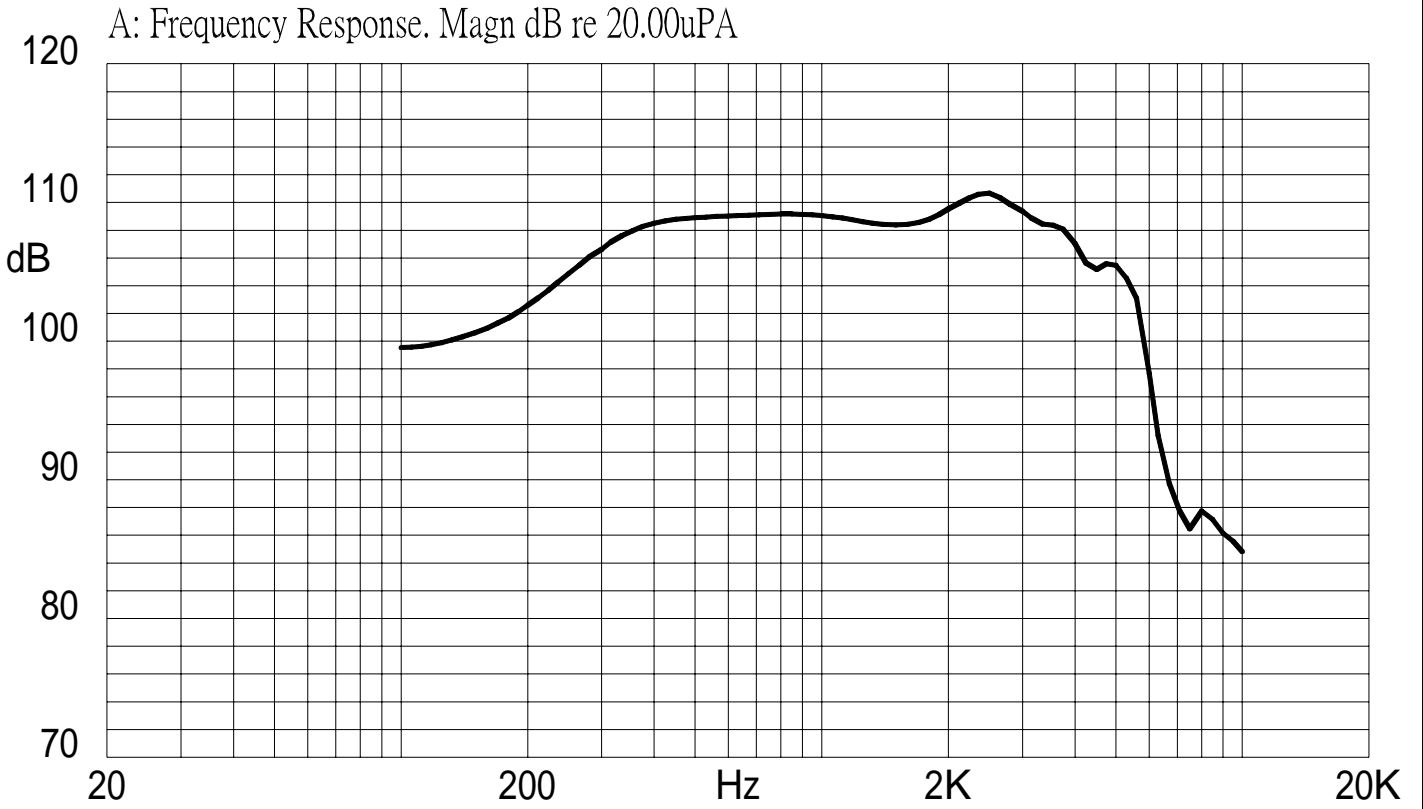

**D. APPEARANCE DRAWING 外觀尺寸圖**

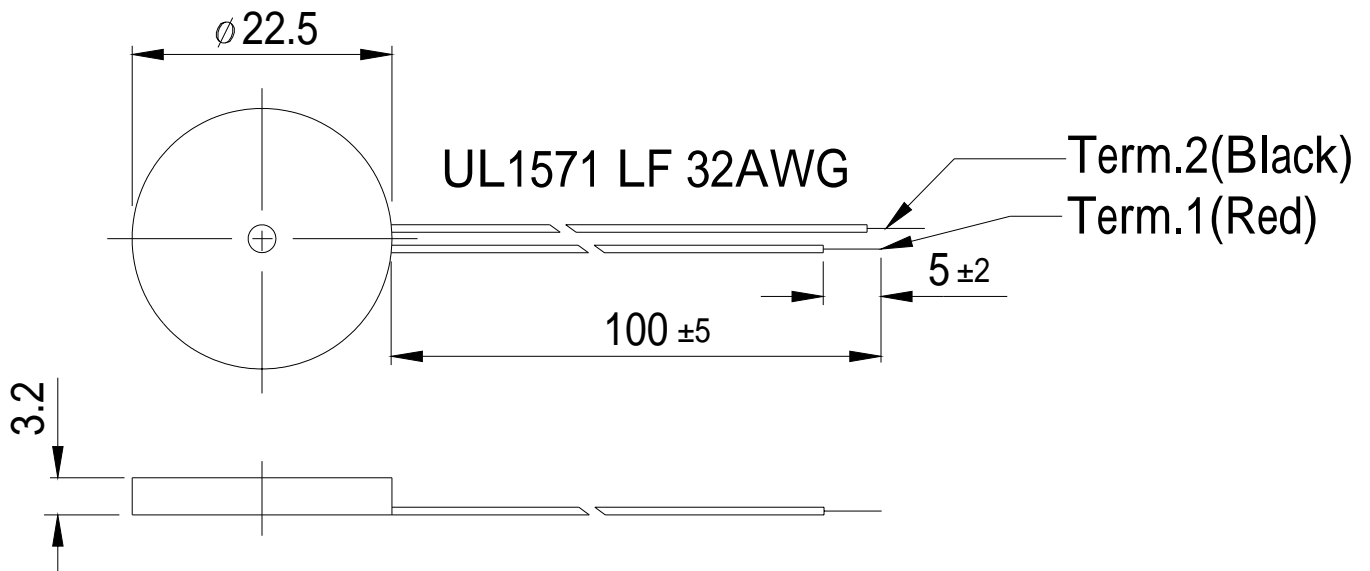

**Tol: ± 0.3**  
**Unit: mm**

**E. MEASUREMENT METHOD 測量路線**

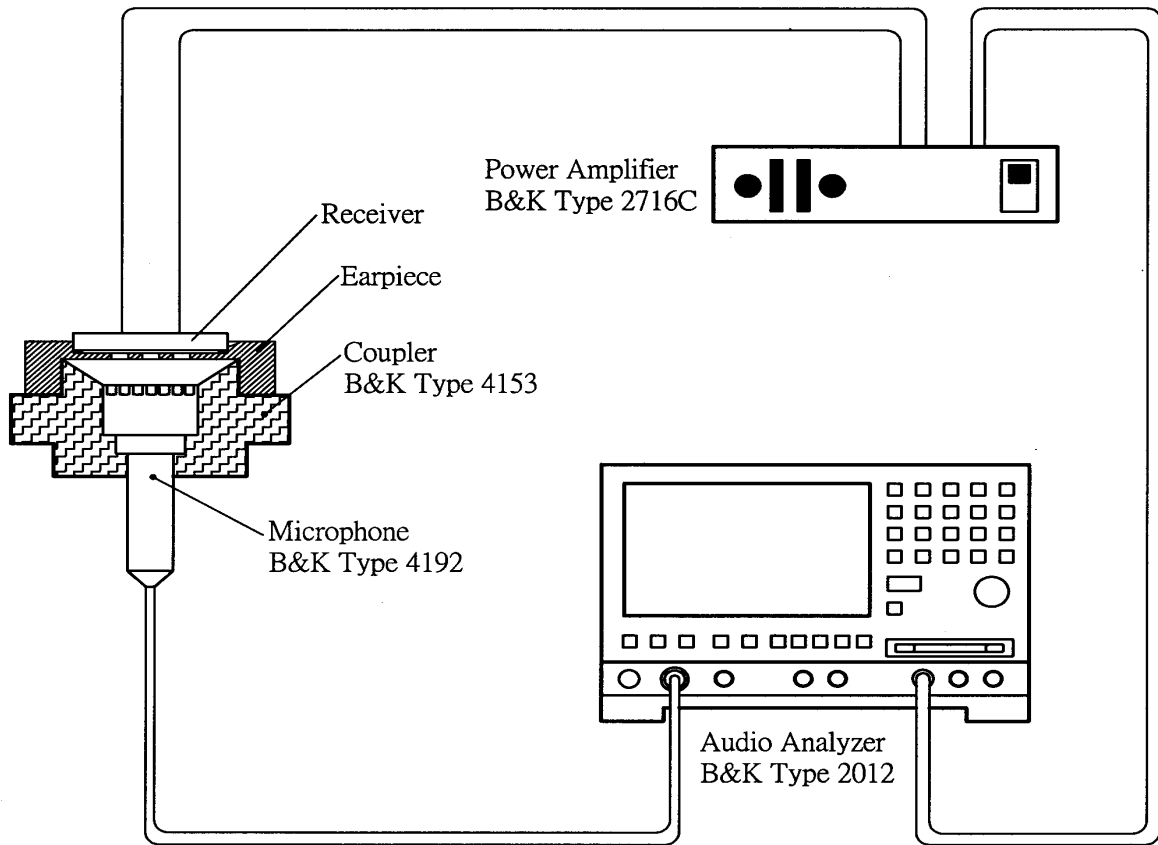

**F. ARPIECE DRAWING**

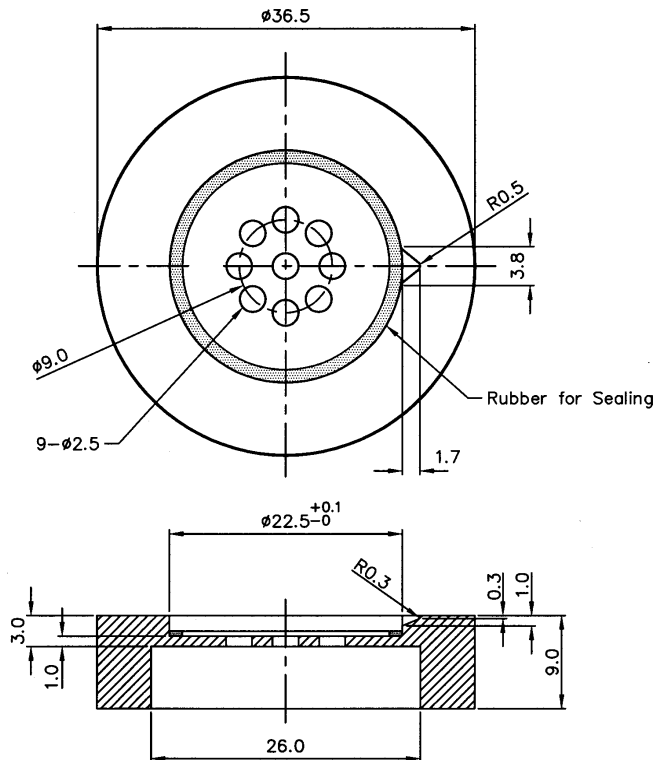

## G. MECHANICAL CHARACTERISTICS 機械特性

No.	Item	Test conditions	Evaluation standard
1	Solderability 焊錫附著性 (Connector excepted) (端子類不適用此項)	Stripped wires of lead wires are immersed in rosin for 5 seconds and then immersed in solder bath of +270±5 for 3±0.5 seconds. 裸線部份浸入松香溶液 5 秒後,再浸入+270±5 熔融焊錫槽 3±0.5 秒.	90% min. stripped wires shall be wet with solder.(Except the edge of terminal) 浸入裸線部份附著焊錫 90% 以上.(末端斷面不算)
2	Lead Wire Pull Strength 線材拉力	The pull force shall be applied to double lead wire : Horizontal 3.0N(0.306kg) for 30 seconds. Vertical 2.0N(0.204kg) for 30 seconds. 雙線材水平方向施以 3.0N(0.306kg) 的力量, 垂直方向施以 2.0N(0.204kg) 的力量,各 30 秒.	No damage and cutting off 線材不鬆動, 不脫落
3	Vibration test 振動測試	Receiver shall be measured after being applied vibration of amplitude of 1.5mm with 10 to 55hz band of vibration frequency to each of 3 per-pendicular directions for 2 hours. 振動週波數 10 ~ 55HZ、全振幅 1.5mm 於 X.Y.Z 3 個方向,各 2 小時.	No obstacle to be harmful to normal operation; damages, cracks, rusts and distortions. Should not be audible at 1.0V sine wave between 250Hz~4KHz
4	Drop test 落下測試	Drop the receiver contained in normal box onto the board 40mm thick 10 times from the height of 75cm 將受話器置於盒中, 自 75 公分高度落在 40mm 木板上共 10 次.	測試後無任何障礙防礙正常操作.且在輸入 1.0V 正弦波從 250Hz 到 4KHz 之間無異常音

## H. ENVIRONMENT TEST 環境測試

No.	Item	Test conditions	Evaluation standard
1	High temp. Test 高溫測試	After being placed in a storage at +95 for 240 hours. 置於+95 環境 240 小時.	Being placed for 2 hours at +25 , receiver shall be measured. No obstacle to be harmful to normal operation; damages, cracks, rusts, etc. Should not be audible at 1.0V, sine wave between 250 ~ 4KHz. S.P.L. deviation of unit should be within ±3.5dB 經測試後, 靜置於+25 (室溫)環境中 2 小時後, 測試後無任何障礙防礙正常操作.且在輸入 1.0V 正弦波從 250 到 4KHz 之間無異常音輸出音壓變化量在±3.5dB 內
2	Low temp. Test 低溫測試	After being placed in a storage at -40 for 240 hours. 置於-40 環境中 240 小時.	
3	Humidity test 相對濕度測試	After being placed in a storage at +40 and 95±5%RH relative humidity for 240 hours. 置於+40 ,相對濕度 95±5%環境中 240 小時	

## I. RELIABILITY TEST 信賴性測試

No.	Item	Test conditions	Evaluation standard
1	Load test 連續負荷	1.0Vrms, white noise is applied for 5 hours at room temp. 在室溫下,輸入功率 1.0Vrms,白雜音連續操作 5 小時.	No obstacle to be harmful to normal operation; damages, cracks, rusts, etc. Should not be audible at 1.0V sine wave between 250~4KHZ. S.P.L. deviation of unit should be within $\pm 3.5\text{dB}$ 測試後無任何障礙防礙正常操作.且在輸入 1.0V 正弦波從 250 到 4KHz 之間無異常音輸出音壓變化量在 $\pm 3.5\text{dB}$ 內

### TEST CONDITION.

Standard Test Condition	: a) Temperature : +5 ~ +35	b) Humidity : 45-85%	c) Pressure : 860-1060mbar
一般測試條件	: a) 溫度 : +5 ~ +35	b) 濕度 : 45-85%	c) 氣壓 : 860-1060mbar
Judgement Test Condition	: a) Temperature : +25 $\pm$ 2	b) Humidity : 60-70%	c) Pressure : 860-1060mbar
爭意時測試條件	: a) 溫度 : +25 $\pm$ 2	b) 濕度 : 60-70%	c) 氣壓 : 860-1060mbar

## J. PACKING STANDARD 包裝規格

