



H970

Switching Power Controller IC

General Description

H970 is a high performance current mode PWM controller. It's specifically designed for AC/DC adapter, providing as high as 12W continuous power output in a wide input voltage range from 85V AC to 265V AC. The peak output power can reach as high as 18W. The controller can be typically used in fly-back circuit topology, formed a simplicity AC/DC adapter. The distinctively start-up circuit, by using bootstrap circuit and the amplified of power transistors, significantly decreases the power dissipation of the start-up resistor. The oscillator frequency will automatically be lower while the output power is smaller. And this will extremely decrease the IC's standby power dissipation. At the off-state of power transistor, the reverse bias of Emit of power transistor let the power source drop to the CB junction of power transistor (up to 700V DC). This directly enhances the safety area of power transistor. Besides, it also includes over load protection, anti-saturation and over temperature protection. These integrated circuits feature can avoid abnormal situation such as overloading, transformers saturation and the short of output that improves the reliability of power device. Current limit and the oscillator frequency can be set by external component.

Features

- Built-in 700 V High Voltage Power Transistor and Few Peripheral Components
- Latching PWM for Cycle-By-Cycle Current Limiting
- The Stand-by Power Dissipation Be Less Than 0.3W.
- Built-in Slope and Feedback Compensation Function
- Independent Up-limit Current circuit Deals with the Over-load and Over Output Current
- During the Off-state of the Power TR, Reversed Bias Voltage of the Emit Improves its Safety.
- Built-in Temperature Compensation to the Current Sensor Resistor, Improving the Precision of the Current Limit.
- Built-in Over Temperature Protection Circuit.
- The Individual Start-up by Using the Magnification of Switch Power Transistor Makes the Power Dissipation of the Start-up Resistance be Reduced More Than 10 Times.
- Few Peripheral Components
- Low Startup and Operating Current
- Over Voltage Protection of VCC
- Not Less Than 12W Continuous Output Power with Wide Range Input, the Peak Output Power be Up to 18W.

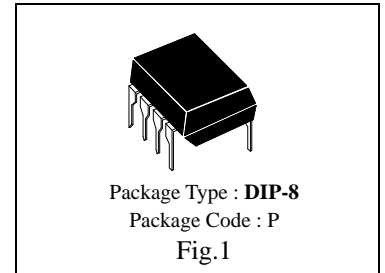



Applications and Typical Application

- AC/DC Adaptor (Ex: Travel Charger, External Power Supply etc.)
- Open Frame (Ex: DVD, DVB etc.)

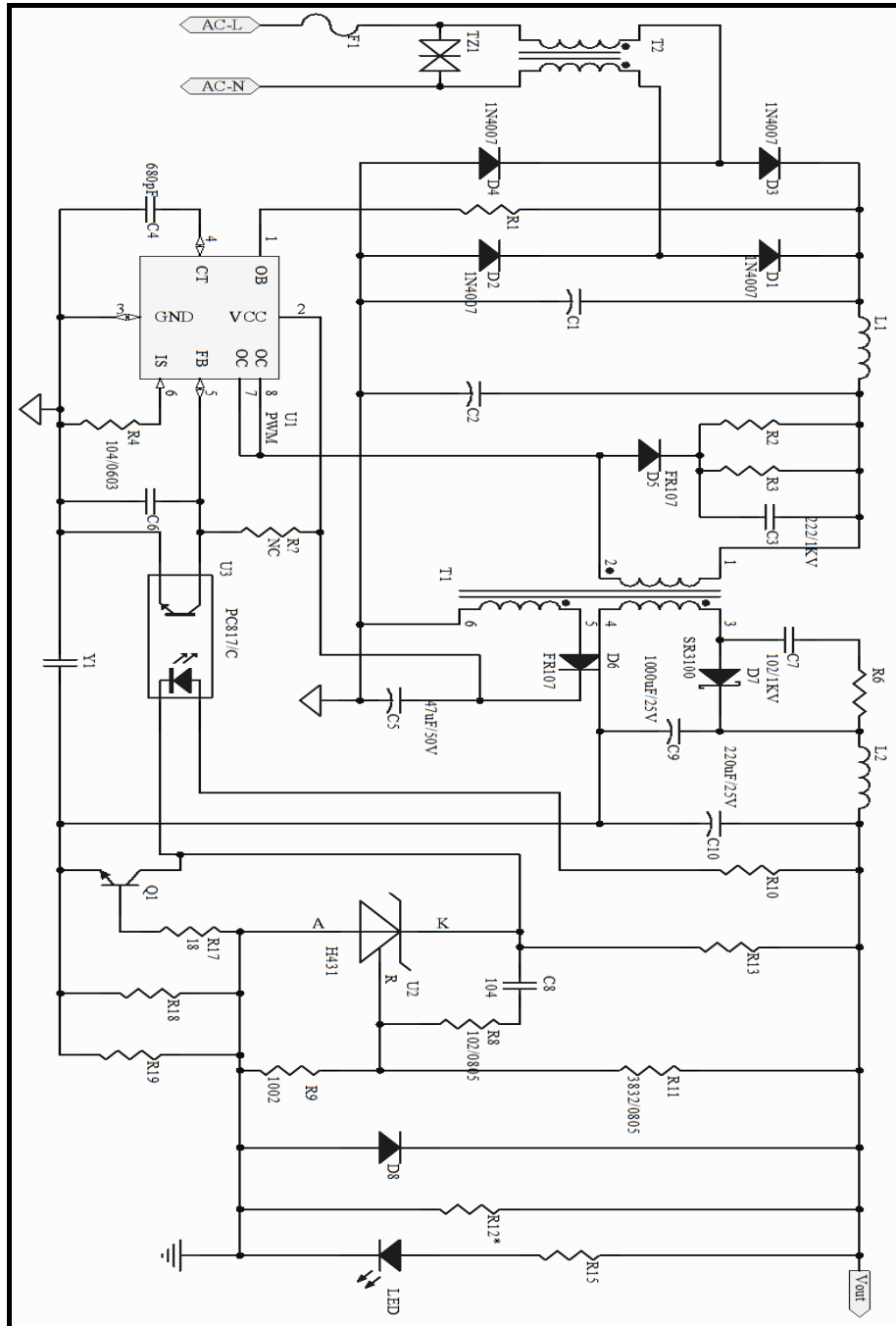

Fig.2 Typical Application Circuit (Input 85~265VAC , output 12V 1A)



Pin Configuration

	Pin1: Base of power transistor; Start-up current control. (OB)	Pin5: This is the non-invert input of the Error Amplifier. (FB)
	Pin2: Power supply. (VCC)	Pin6: Current Sensor Pin. And the built-in resistor is about 3.5 ohm. (IS)
	Pin3: Ground. (GND)	Pin7: Collector of output power transistor. (OC)
	Pin4: The oscillator frequency is programmed by connecting capacitor CT to ground.(CT)	Pin8: Collector of output power transistor. (OC)

Note1: During the PCB designing, it must be kept at least 1.1mm between Pin6 and Pin7 to avoid electric arc.

Block Diagram

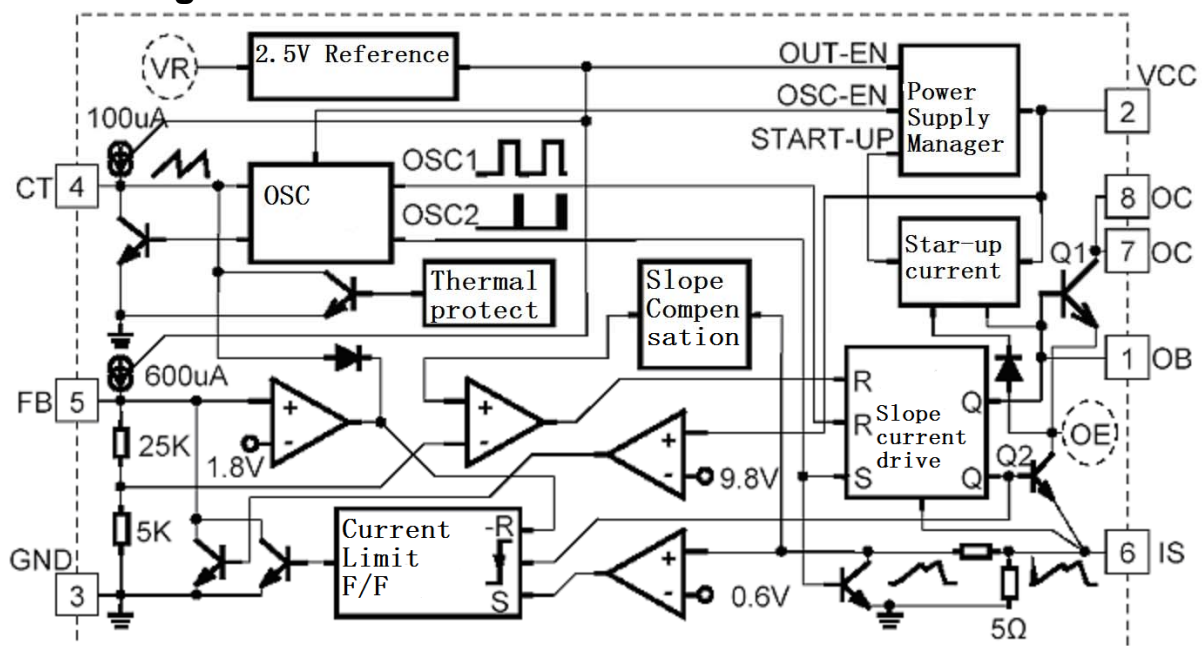

Fig.3 Block Diagram of H970

Absolute Maximum Ratings

Parameter	Symbol	Rating	Unit
MAX Supply Voltage	VCC	16	V
Start-up Input Voltage	V _{STAR}	16	V
Voltage Add to OC	V _{OC}	-0.3~700	V
Switch Peak Current	I _{PK}	800	mA
Power Dissipation	P _D	1000	mW
Thermal Res. Junction-ambient (Note2)	R _{θJA}	70	°C /W
Junction Operating Temp.	T _{OP}	0~+125	°C
Storage Temperature Range	T _{Stg}	-55~+150	°C

Note2 : (1) Pin7,8 be connected with a copper, and its area be at least 200 square millimeter.



Recommend Operation Conditions

Parameter	Symbol	Min.	Typ.	Max	Unit
Supply Voltage	VCC	4.8	5.5	8.0	V
Invert Peak Voltage	V _{OC}	-	-	520	V
Switch Peak Current	I _{PK}	-	-	600	mA
CT Capacitor	CT	650	820	920	pF
Oscillator Frequency	F _{OSC}	45	60	65	KHz
Operation Temperature	T _A	0		70	°C

Electrical Characteristics

Unless otherwise stated, specifications apply for T_a=25°C · VCC=5.5~7.5V · CT=820pF · RS=1Ω (Note3)

Parameter	Symbol	Test Conditions	Min.	Typ.	Max	Unit
OUTPUT SECTION						
Breakdown Volt. of Switch TR	V _{OCM}	I _{OC} =1.0mA	700	-	-	V
V _{sat} of Switch TR	V _{sat}	I _{OC} =600mA	-	-	1	V
Rise Time of Output	T _R	CL=1nF	-	-	75	nS
Fall Time of Output	T _F	CL=1nF	-	-	75	nS
Output Limited Current	I _{LIM}	T _J = 0~100°C	540	580	620	mA
OE Clamp Voltage	V _{OEM}	OE=0.001~0.60A	-	1.5	-	V
REFERENCE SECTION						
Reference Voltage	V _{REF}	I _o =1.0mA	2.4	2.5	2.6	V
Line Regulation	ΔV _O	VCC=5.5~9V	-	2	20	mV
Load Regulation	ΔV _O	I _o =0.1~1.2mA	-	-	3	%
Temperature Stability	ΔV _O /ΔT	T=0~85°C	-	0.2	-	mV/°C
Noise Output Voltage	V _N	F=10Hz~10KHz	-	-	50	μV
Long Term Stability	V _{STB}	T=85°C · 1000h	-	5	-	mV
OSCILLATOR SECTION						
Frequency	F _{OSC}	CT=820pF	55	61	67	KHz
Frequency Change with VCC	ΔF _{OSC} / F _{OSC}	VCC=5.5~9V	-	-	3.5	%
Frequency Change with Temp.	ΔF _{OSC} / F _{OSC}	T _a =0~85°C	-	-	1	%
V _{PP} of Oscillator Output	V _{PP}		-	2.5	-	V
T _F of Oscillator Output	T _F	Ct=820pF	-	800	-	ns
FEEDBACK SECTION						
Input Impedance	Pull-up Current	I _{UP}	-	500	650	uA
	Pull-down Resistance	R _{FB}	-	20	-	KΩ
PSRR	PSRR	VCC=5.5~9V	-	60	70	dB
CURRENT SENSOR (IS) SECTION						
Current Sensor Threshold	V _{TH}		0.54	0.58	0.62	V
Current Limited	I _{LIM}		0.54	0.58	0.62	A
PSRR	PSRR		-	60	70	dB
Delay	T _D		-	150	250	ns



PWM SECTION						
Maximum Duty Cycle	D_{MAX}		53	57	61	%
Minimum Duty Cycle	D_{MIN}		-	-	3.5	%
POWER SUPPLY SECTION						
Startup OC Current	I_{OC}		1.6	2.0	2.4	mA
OB Startup Supply Current	I_{OB}		-	55	80	μ A
Operating Supply Current	I_{CC}	VCC=8V	-	2.8	-	mA
Start-up Voltage	V_{ON}		8.6	8.8	9.0	V
Oscillator Shut-down Voltage	V_{OFF}		4.0	4.3	4.5	V
Re-startup Voltage	V_{RES}		-	3.7	-	V
Over Voltage Threshold	OVP		9.2	9.6	10.0	V

Note3: RS is a peripheral component of Pin6.

Application Hints

Description of the Principle

- During start-up phase, VR is closed when electrified; FB pull-up power source is closed, the start-up current inputs from power TR to VCC through OE; OB controls the base current of power TR and limits the collector current of power TR (namely, the acceptance current of H970 during its starting up). Then, it ensures the security of the power TR; when VCC voltage once goes up to 8.8V, it comes into the normal phase.
- During normal phase, VCC voltage stable at 4.8~9.0V, VR stables at 2.5V reference voltage. FB pull-up current source starts up. The OSC1 output of oscillator decides the maximum duty cycle; OSC2 triggers the power supply to enter its open cycle and limits the flashing peak current of the power TR. If FB is less than 1.8V (at about 1.2~1.8V), the period of the oscillator will increase with, the less FB is, the wider the period of the oscillator is, until the oscillation stops. This characteristic reduces the standby power consumption of the switch power. If the peripheral feedback tries to make VCC more than 9.6V, the built-in circuit feeds back to FB and keeps the VCC voltage at about 9.6V. According to this characteristic, we may not adopt peripheral feedback circuit. The output voltage could be stabilized by its built-in circuit.

During the open stage, OB supplies base current for the power TR, OE pulls down the emitter current of the power TR to IS, and OB adopts the driving parameter of slope current. That refers to the OB on-current is the functions of IS's current when IS's voltage of IS is 0V, OB on-current is about 40mA, then OB on-current increases linearly with IS's voltage, when IS increases to 0.6V, OB on-current is about 120mA. This makes effective use of the output current of OB, and decreases the power consumption of H970. If PWM comparator detects the specified current through the slope compensation, H970 will be forced to come into the close cycle.

During the close cycle, OB pulls down the power TR's base level, and OE's level is clamped to 1.5V. This makes the base be biased reversely after the power TR is shut off, which really raises the security area of the TR.

During open or close cycle, if the power TR is detected beyond by the upper limit current, the trigger of the upper limit current will be set for priority and forces FB to drop, meanwhile the duty



cycle will become less so as to protect the power TR and transformer; at the beginning of next close cycle or when FB is less than 1.8V, the trigger of the upper limit current will be reset. In addition, H970 has built-in OTP function, that is, when the internal temperature is higher than 140°C, the period of the oscillator will be increased and this makes the temperature of H970 lower than 150°C. A slope compensation circuit is also built-in internally; it can stabilize the transformation between the open cycle and close cycle, when H970 runs in a large duty cycle or in a constant current mode.

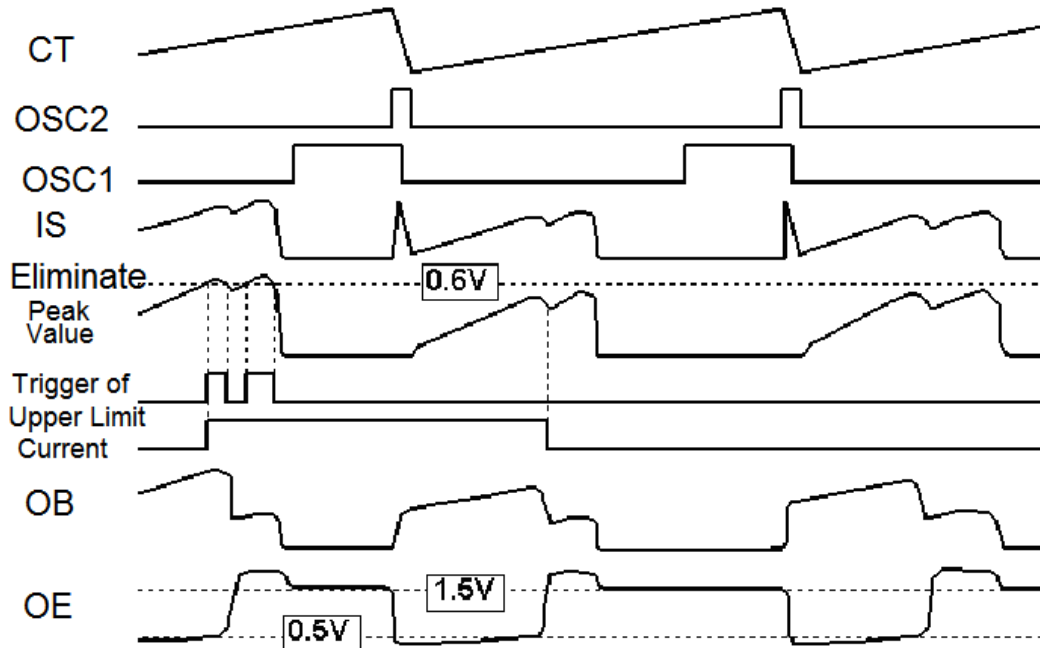

Fig.4 Waveform Graph of Open and Close Cycle at Normal Phase

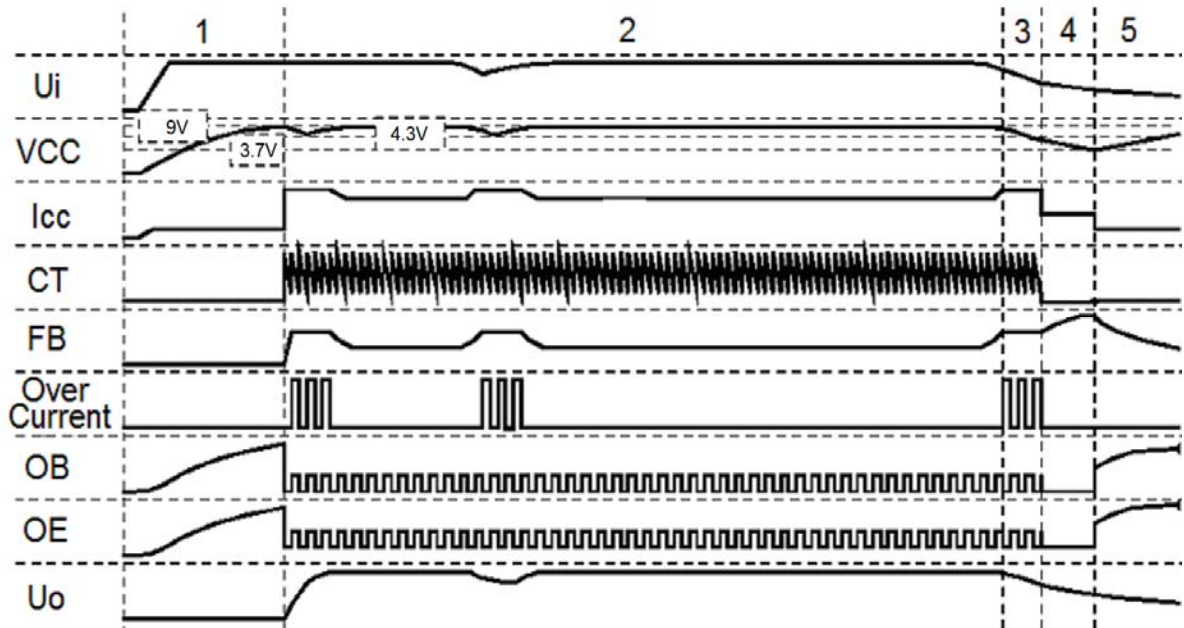

Fig.5 Timing Diagrams of H970

- If VCC declines to about 4.3V, the oscillator will shut off, OSC1 and OSC2 will drop to low level, and the output keeps at close cycle; when VCC continuously declines to about 3.7V, H970 will restart the phase again.



Definition of Terms and Electrical Parameters

- Start-up Acceptance Current: the current through OC when OB inputs 0.5mA during the start-up stage.
- Start-up Quiescent Current: the current of minimum current source that can make CT oscillate (namely finish the start-up of H970), when VCC is connected with filter capacitance and adjustable current source, CT is connected with 820pF, and other pins are suspended.
- Start-up Voltage: Maximum VCC supply voltage when CT starts to oscillate.
- Re-start Voltage: Minimum VCC supply voltage when VR drops to zero voltage.
- Oscillator Shut Down Voltage: VCC supply voltage when CT stops to oscillate.
- Quiescent Current: VCC consumption current when FB is connected with 1.0K resistance to the ground at normal phase.
- Pull-up/pull-down Current of the Oscillator: The pull-up/pull-down current on CT when FB is 2.5V and CT is 1.25V at normal phase.
- FB Pull-up Current: Pull-up current on FB when FB is 2.5V, IS is 0V at normal phase.
- FB Upper Limit Current Prevention: The pull-down current on FB when FB is 6V, IS is 0.3V at normal phase.
- Internal Feedback Power Voltage: VCC value of H970 power supply without any peripheral feedback circuit at normal case
- OC Upper Limit Voltage: the minimum OC current of pull-down current on FB when FB is 6V
- Slope current drive: it refers to the OB drive on-current of the power TR, ant it is the function of IS's voltage. OB on-current is about 40mA, when IS is 0V; then it will increase linearly with IS's voltage to 120mA when IS's voltage reaches 0.6V.

Application Information:

1. Relationship between CT timing capacitance and switching frequency

CT capacitance is charged by 110uA constant current through internal current source for the rise-up edge of the clock. When the voltage is charged to 2.5V, the internal circuit will discharge CT with 1.9mA of pull-down current forming the fall-down edge of the clock, and accomplish a clock cycle, which is about:

$$T = CT * 20000 (S) \dots\dots\dots (1)$$

Although the bipolar circuit can operate under higher frequency, considering the influence of switch loss for the storage time, the switching characteristic of bipolar power transistor, generally, the appropriate switching frequency is

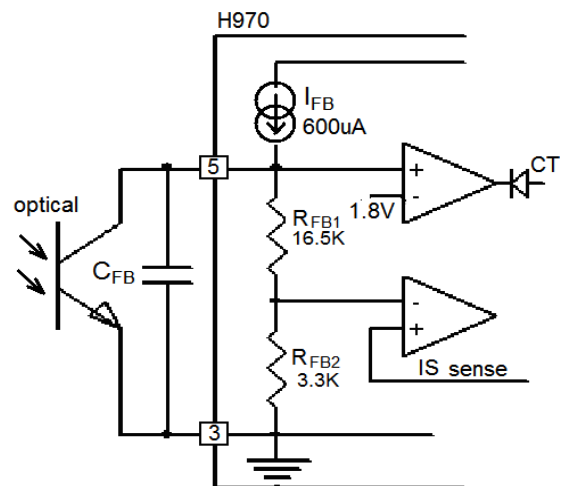

Fig.6 FB Feedback and Control



about below 70 KHz. In general situation, CT capacitance of H970 can be set by 820pF when the relevant operation frequency is around 61 KHz.

2. FB feedback and control

In normal operation state, the voltage of FB will decide the value of the maximum switching current, the higher the voltage is, the larger the switching current it is (within the maximum peak current). FB pin's pull-up current is 600uA internally; the pull-down resistance is about 20 K Ω (an approximation equivalent value). On the other side, when FB voltage drops to under 1.8V, the oscillator frequency will be decreased and switching frequency will also decline, the lower the FB voltage, the lower the switching frequency. The external FB capacitance will influence the feedback bandwidth, such as the transient-state characteristic changed with the value of C_{FB} capacitance. The value of C_{FB} capacitance typically ranges from 10nF to 100nF, according to the frequency characteristic of feedback circuit.

3. Over temperature protection

The interior of IC integrates the function of over temperature protection. When the internal temperature of the chip reaches 140 $^{\circ}\text{C}$, the over-heat temperature circuit does activate (i.e. it pulls down the clock signal, and the switching frequency will fall until the oscillator is turned off showing in the figure 7).

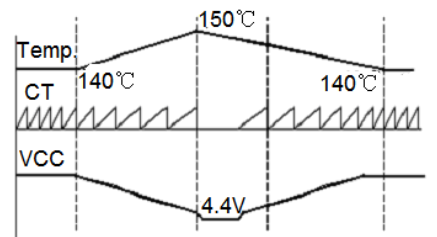

Fig.7 OTP waveform

4. Driving characteristic and high voltage endurance bias technology of power TR

The power TR adopts the slope current drive, the driving current will increase with the output power, when FB is 0V, the current of OB is about 40mA; when FB is 6V, the current of OB is about 120mA; the driving power consumption will decrease remarkably when the output is low.

The interior of IC integrates the particular bias technology, when the power TR is shut, the OB voltage will be pulled down to the ground; meanwhile, the OE will be locked to 1.5V or so. And this makes the emitter junction bias reversely, accelerates the decreasing speed of I_{OC} current, expends the effective safe operation area, therefore, the endurance

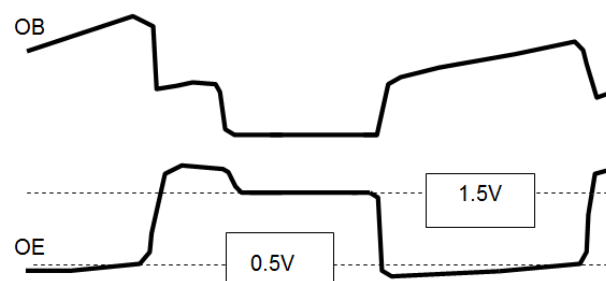

Fig.8 OB OE bias waveform of H970

characteristic of the switching TR can be up to 700VDC. For more detail information for the voltage endurance characteristic of the switching TR, please see also the relevant technical data. The bias waveform is shown in the figure8.



5. Over voltage and under voltage protection

H970 has the function of slow-moving under-voltage protection. When the voltage of VCC reaches 8.8V, the product begins to work, the initial start-up voltage is provided by the driving resistance, the high input voltage will be injected into the base of the switching TR through OC, and consequently, the driving voltage is built up. In normal state, the voltage of VCC should be kept between 4.8V to 9V, including the situation of full load output. If the voltage of VCC falls to 4.3V, the oscillator will enter the state of shut-off; when it decreases to or under 3.7V, H970 will restart again.

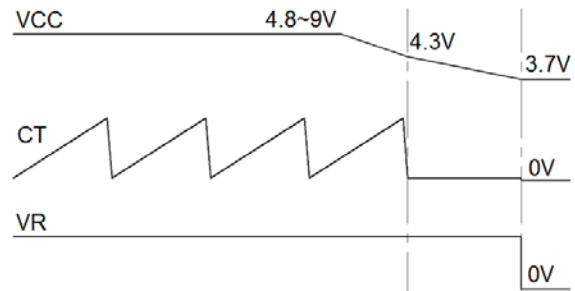

Fig.9 OVP UVP Time Diagram

In figure 9, there is an upper limit voltage comparator in the IC, when VCC reaches the OVP set point (about 9.6V), the output of the comparator will force the FB to be pulled down, and also lock VCC voltage to about 9.6V; meanwhile, it is easy to accomplish the voltage feedback function of the front terminal. During the OVP stage, the current limit circuit does also work, the power TR is closed; and this avoids raising the output voltage during the open-loop output, so as to guarantee the security of the load. Cause of this characteristic, the design of H970's power supply should be kept at proper range, to avoid raising the VCC excessively high when the output is high; and this also can avoid decreasing the Adaptor's output when H970's OVP function works.

6. Maximum switching current limit

H970 has the function of current limit cycle by cycle. It will detect every switching current in each switching cycle. If the current is reached the set value, which is decided by FB or upper limit prevention, it will come into the close cycle. The detection of the current has real-time foreland hide, it can limit the switching peak current value and avoid the wrong detection of the switching current. The reasonable temperature compensation eliminates the influence of temperature, comparing with normal MOSFET switching chip (the alteration of R_{ON} will be varies when the temperature changes), the switching current can always be more accurate in a width range. Thus, it needn't consider much tolerance for designer to design to meet with a larger working temperature range; also, the security of the circuit is improved.

The maximum limit value of switching current for H970 is 800mA. When designing a fly-back power with 65V emitter voltage and 0.8A switching current, it is enough for the output power of more than 12 watt.

7. Requirement of heat elimination

As for a typical power switch, it must have necessary heat elimination measures, so as to avoid the over heat protection

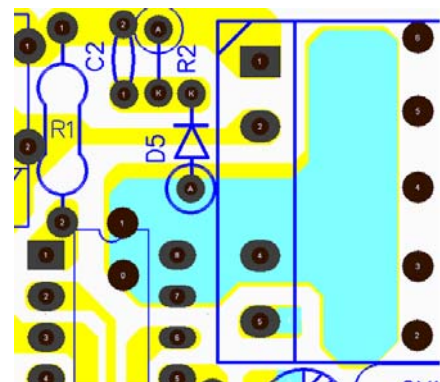

Fig. 10 Reference Wiring Layout



occurring earlier because of the excessive heat phenomenon. The primary heat source is the power TR in the H970, at the moment of the turning on and off time of the switching TR. So, the appropriate heat elimination is needed; that is the Pin7-8 the H970. A facility and economic way is to pave PCB copper foil of certain area on Pin7 and Pin8; what's more, plating tin on the copper foil will greatly improve the heat elimination ability. For instant, the 200mm² copper foils are needed for the typical application of 12 watt output with an input of 85VAC~265VAC. Figure 10 is a Reference wiring layout.

8. Performance Evaluation

See also Fig.2 above. The primary waveform of testing point show below:

1). Pin7 to Pin3 (V_{OC}) waveform diagram:

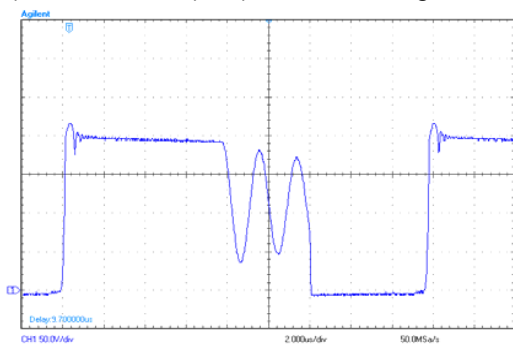

Fig. 11 $V_{IN}=85VAC$, $I_o=0.5A$

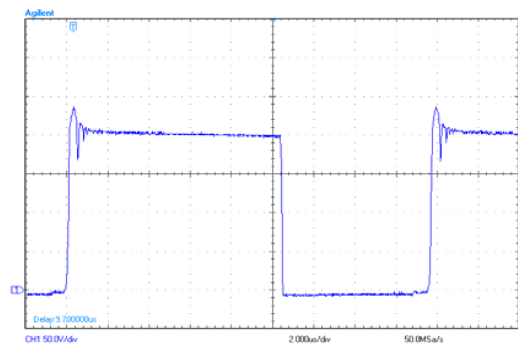

Fig. 12 $V_{IN}=85VAC$, $I_o=1A$

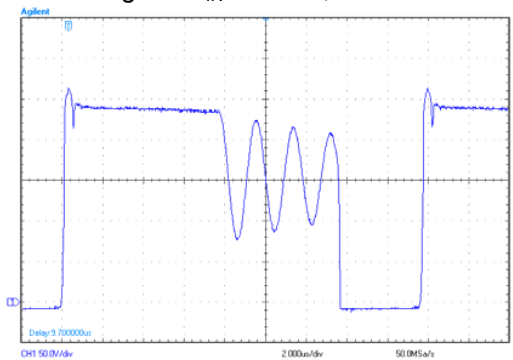

Fig. 13 $V_{IN}=110VAC$, $I_o=0.5A$

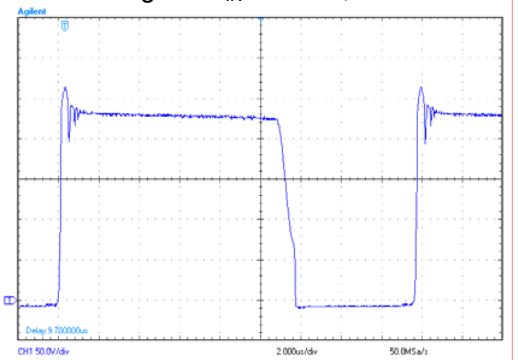

Fig. 14 $V_{IN}=110VAC$, $I_o=1A$

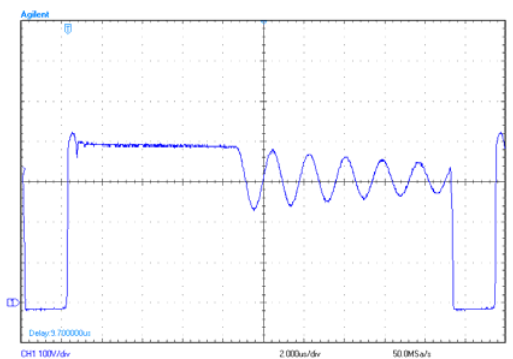

Fig. 15 $V_{IN}=220VAC$, $I_o=0.5A$

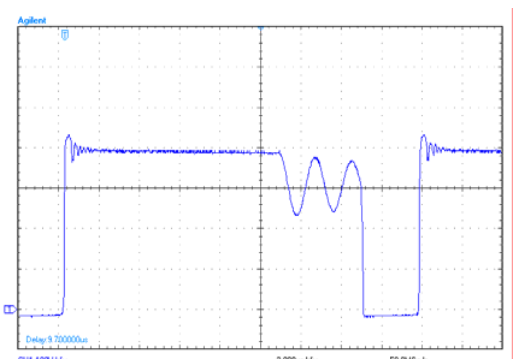

Fig. 16 $V_{IN}=220VAC$, $I_o=1A$

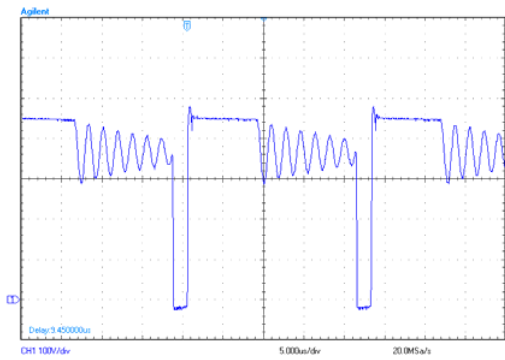

Fig. 17 $V_{IN}=265VAC$, $I_o=0.5A$

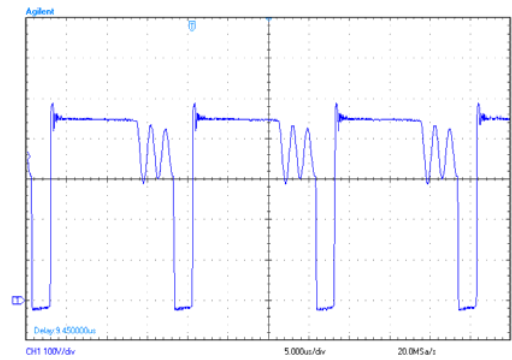

Fig. 18 $V_{IN}=265VAC$, $I_o=1A$

2). Output noise waveform

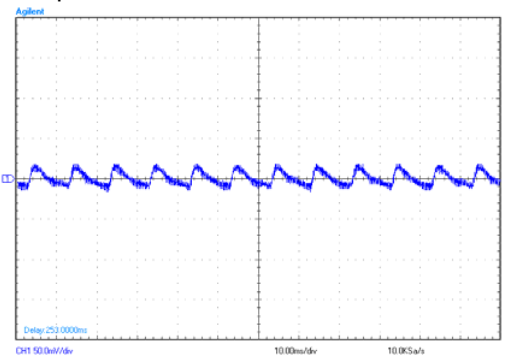

Fig. 19 $V_{IN}=85VAC$, $I_o=1A$

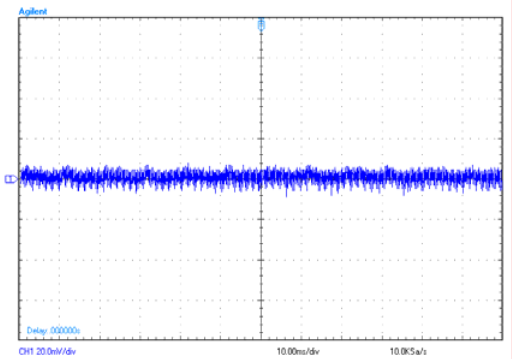

Fig. 20 $V_{IN}=265VAC$, $I_o=1A$

3). Output ripple waveform

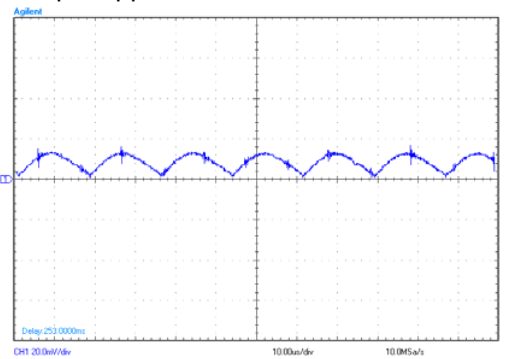

Fig. 21 $V_{IN}=85VAC$, $I_o=1A$

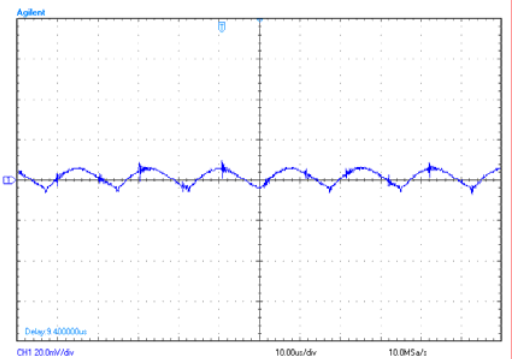

Fig. 22 $V_{IN}=265VAC$, $I_o=1A$

4). Output waveform on start-up

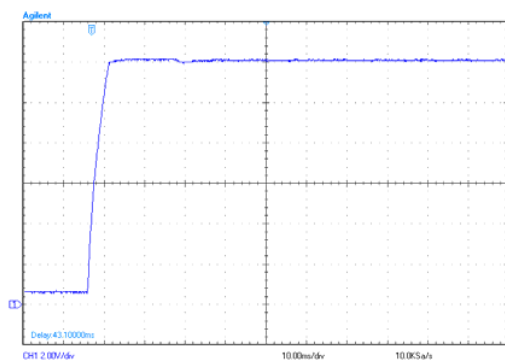

Fig. 23 $V_{IN}=85VAC$, $I_o=1A$

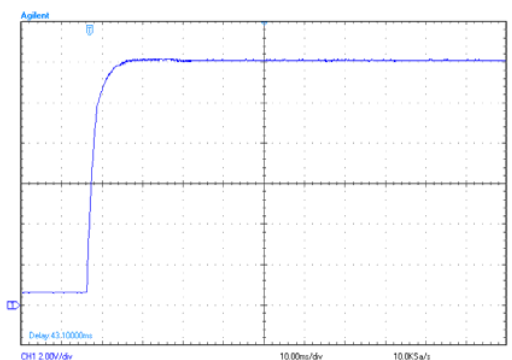

Fig. 24 $V_{IN}=265VAC$, $I_o=1A$



5). V_{OC} to ground and V_o waveform on start-up

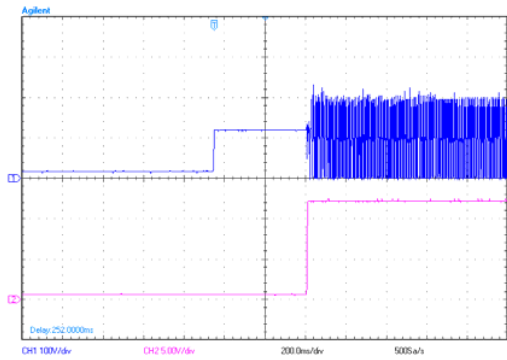

Fig. 25 $V_{IN}=85VAC$, $I_o=1A$

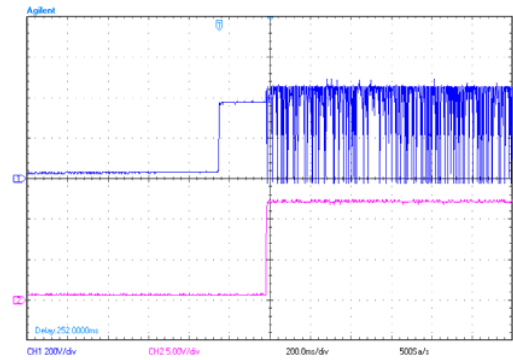

Fig. 26 $V_{IN}=265VAC$, $I_o=1A$

6). V_{OC} to ground waveform when the output is short

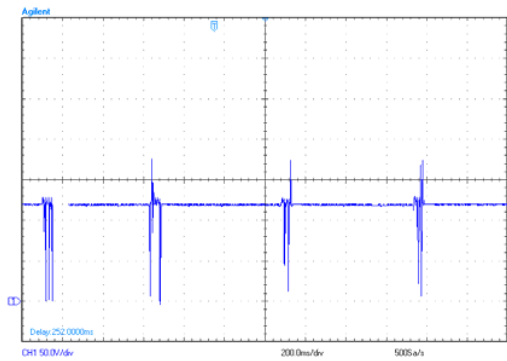

Fig. 27 $V_{IN}=85VAC$, Output Short

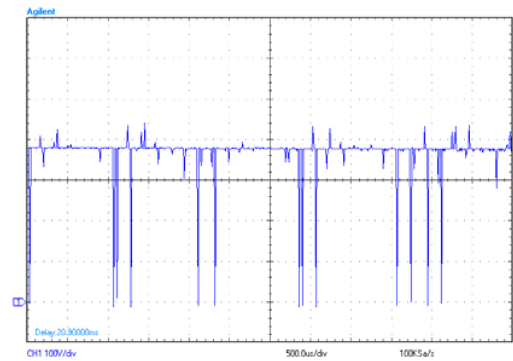

Fig. 28 $V_{IN}=265VAC$, Output Short



7). Diagram of Switch efficiency:

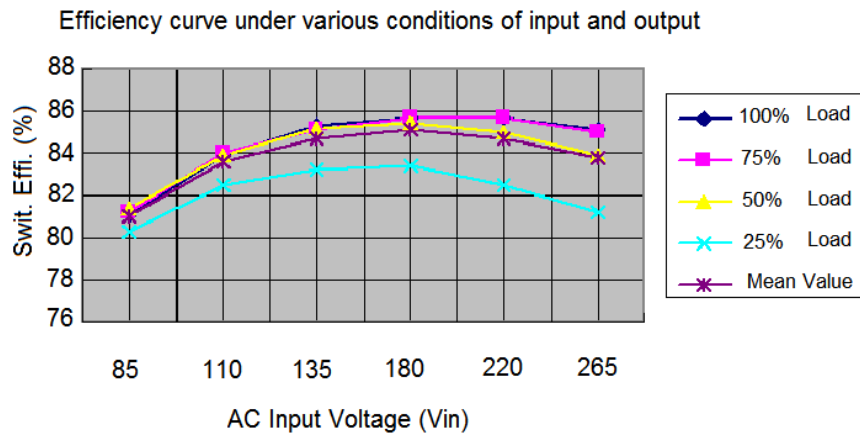

Fig.29 Reference Swit. Effi. vs. AC Input Voltage

8). Input power consumption:

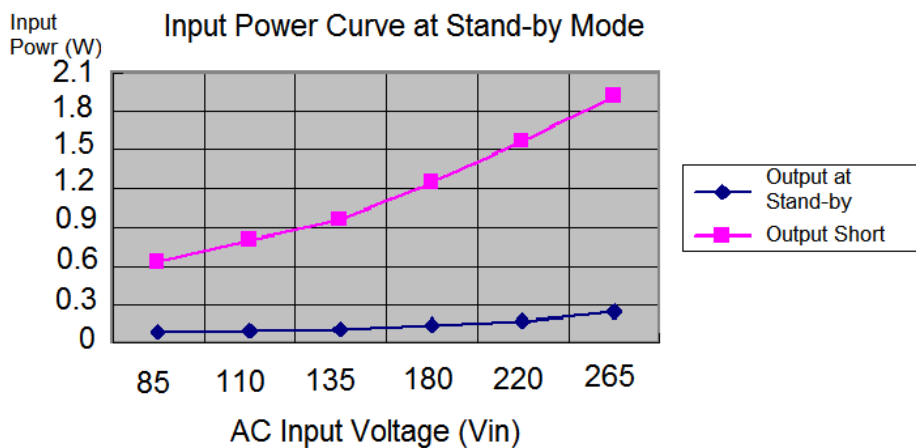
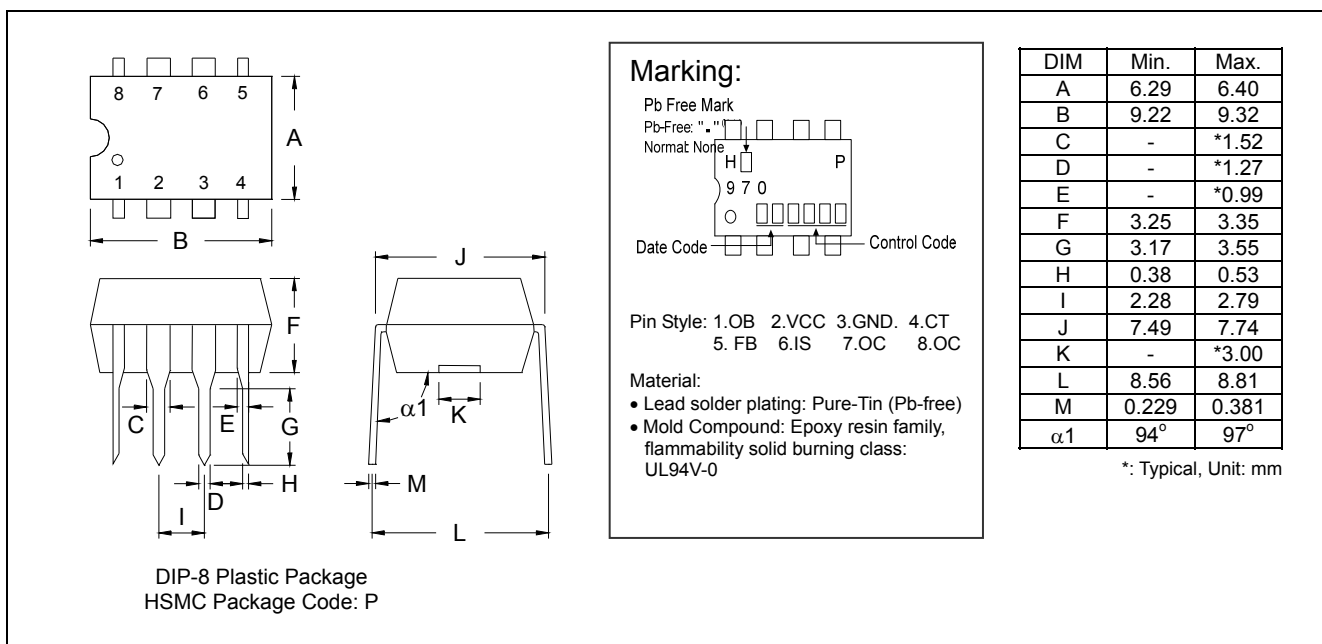

Fig.30 Input Power Consumption vs. Output State



DIP - 8 Package Dimension



Important Notice:

- All rights are reserved. Reproduction in whole or in part is prohibited without the prior written approval of HSMC.
- HSMC reserves the right to make changes to its products without notice.
- HSMC semiconductor products are not warranted to be suitable for use in Life-Support Applications, or systems.
- HSMC assumes no liability for any consequence of customer product design , infringement of patents , or application assistance.

Head Office:

•Head Office(Hi-sincerity Microelectronics Corp.): 5/F., Golden Harvest Building, 15 Wang Chiu Road, Kowloon Bay, Hong Kong
 Tel: +852-2755-7162 Fax: +852-2755- 7795

AVANTICS:Shanghai Address: No.399, Cai Lum Rd. Zhangjiang Technology Industrial Park Pudong, Shanghai 201210, China
 Tel: +86(21) 61637118 Fax: +86(21)61637006