

# GS431

## Adjustable Precision Shunt Regulators

### Product Description

The GS431 is a three-terminal adjustable shunt regulator with specified thermal stability.

The output voltage may be set to any value between  $V_{REF}$  (approximately 2.5V) and 36V with two external resistors.

This device has a typical output impedance of  $0.2\Omega$ . Active output circuitry provides very sharp turn-on characteristics, making this device excellent replacement for Zener diodes in many applications.

GS431 is available in TO-92, SO-8, SOT-89 and SOT-23 packages

### Features

- Equivalent Full Range Temperature Coefficient 30ppm/°C
- Temperature-Compensated for Operation over Full Rated Operating Temperature Range.
- Sink Current Capability 1mA to 100mA
- Adjustable Output Voltage
- Low ( $0.2\Omega$  Typ.) Dynamic Output Impedance
- Low Output Noise
- Fast Turn-on Response
- RoHS Compliant, 100%Pb & Halogen Free

### Applications

- Battery Operated Computer
- Switching Power Supplies
- Adjustable Power Supplies
- Linear Regulators
- Instrumentation
- Computer Disk Drivers

### Block Diagram & Symbol

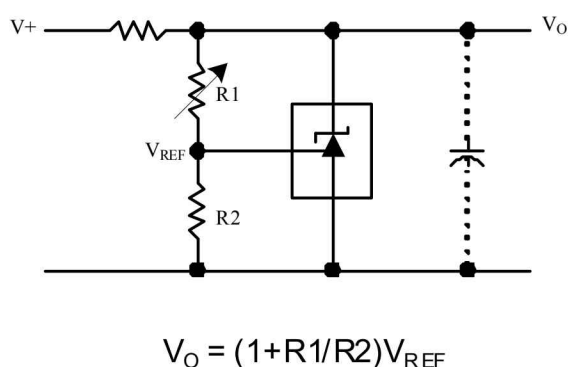

Figure 1. Shunt Regulator

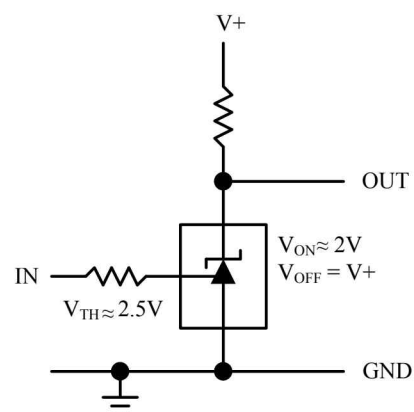
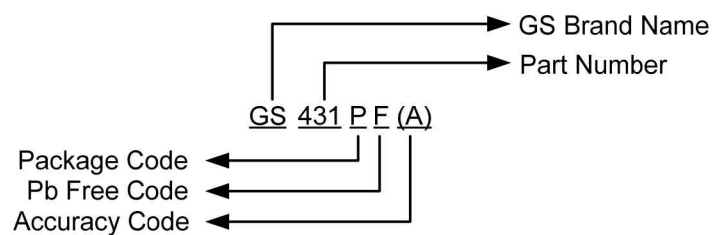

Figure 2. Single Supply Comparator with Temperature Compensated Threshold

## Packages & Pin Assignments

GS431JZ (SOT-23)		GS431JW (SOT-23)		GS431Z (SOT-23-3L)		GS431W (SOT-23-3L)		
1	REF	1	CATHODE	1	REF	1	CATHODE	
2	CATHODE	2	REF	2	CATHODE	2	REF	
3	ANODE	3	ANODE	3	ANODE	3	ANODE	
GS431Y (SOT-89)		GS431N (TO-92)		GS431S (SO-8)				
1	REF	1	REF	1	CATHODE	5	NC	
2	ANODE	2	ANODE	2	ANODE	6	ANODE	
3	CATHODE	3	CATHODE	3	ANODE	7	ANODE	
				4	NC	8	REF	

## Ordering Information



Device	Package
GS431JWF	SOT-23
GS431JZF	SOT-23
GS431WF	SOT-23-3L
GS431ZF	SOT-23-3L
GS431NF	TO-92
GS431SF	SOP-8
GS431YF	SOT-89

- GS TO-92 package type have already used "Lead Free" process in 2000, so GS product without marked "F" to different.
- Accuracy Range : (A) means 0.5% accuracy, (B) means 1% accuracy.

## Marking Information

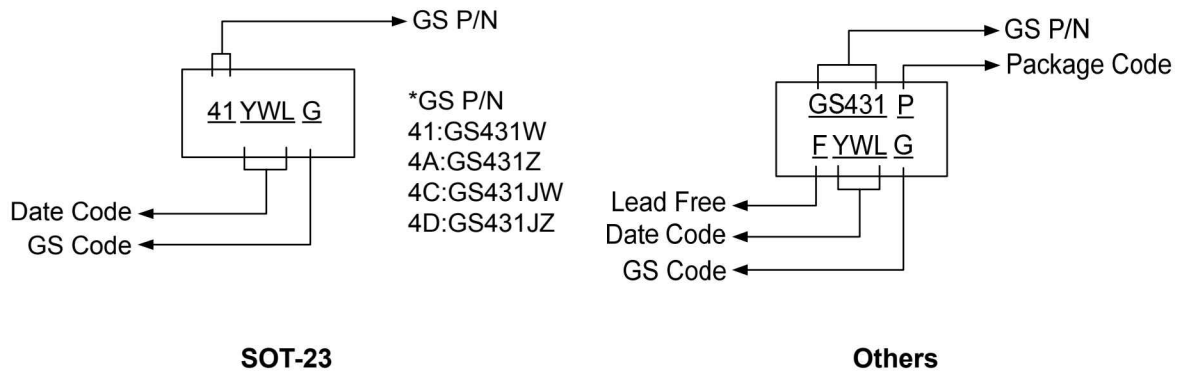

## Absolute Maximum Ratings

Over operating free-air temperature range (unless otherwise noted)

Symbol	Parameter	Rating	Unit
$V_{KA}$	Cathode Voltage ( <b>Note 1</b> )	36	V
$I_K$	Continuous Cathode Current Range	1 to +100	mA
$I_{REF}$	Reference Current Range	-50 $\mu$ A to 10mA	mA
$\theta_{JA}$	Thermal Resistance Junction To Ambient	SOT-23 833 SOP-8 192 SOT-89 250 TO-92 250	$^{\circ}$ C/W
$P_D$	Power Dissipation	SOT-23 0.15 SOP-8 0.625 SOT-89 0.5 TO-92 0.5	W
$T_{OPR}$	Operating Temperature Range	-40 to 85	$^{\circ}$ C
$T_J$	Junction Temperature Range	0 to 125	$^{\circ}$ C
$T_{STG}$	Storage Temperature Range	-65 to 150	$^{\circ}$ C
$T_{LEAD}$	Lead Temperature Range(Soldering, 10sec)	260	$^{\circ}$ C

**Note 1:** Voltage values are with respect to the anode terminal unless otherwise noted.

## Electrical Characteristics

Electrical Characteristics at 25°C free-air temperature (unless otherwise noted).

Symbol	Parameter	Conditions	GS431(A)			GS431(B)			Units
			Min	Typ	Max	Min	Typ	Max	
$V_{REF}$	Reference Voltage	$V_{KA}=V_{REF}$ , $I_K=10mA$	2.487	2.500	2.513	2.474	2.500	2.526	V
$V_{DEV}$	Deviation of reference input voltage over full temperature range	$V_{KA}=V_{REF}$ , $I_K=10mA$ , $T_A = \text{Full range}$ (Test circuit 1)		4.0	17		4.0	17	mV
$\frac{\Delta V_{REF}}{\Delta V_{KA}}$	Ratio of change in reference input voltage to the change in cathode voltage	$I_K=10mA$ , $\Delta V_{KA}=10V \text{ to } V_{REF}$ $\Delta V_{KA}=36V \text{ to } 10V$	-2.7 -2	-1.0 -0.4		-2.7 -2	-1.0 -0.4		mV/V
$I_{REF}$	Reference input current	$I_K=10mA$ , $R1=10K\Omega$ , $R2=\infty$ (Test circuit 2)		0.7	4.0		0.7	4.0	$\mu A$
$I_{REF (DEV)}$	Deviation of reference input current over full temperature range	$I_K=10mA$ , $R1=10K\Omega$ , $R2=\infty$ , $T_A = \text{Full range}$ (Test circuit 2)		0.4	1.2		0.4	1.2	$\mu A$
$I_K (\text{min})$	Minimum cathode current for regulation	$V_{KA} = V_{REF}$ (Test circuit 1)		0.4	1.0		0.4	1.0	mA
$I_K (\text{off})$	Off-state cathode current	$V_{KA}=36V$ , $V_{REF}=0$		0.1	1.0		0.1	1.0	$\mu A$
$ Z_{KA} $	Dynamic impedance	$f < 1KHz$ , $V_{KA} = V_{REF}$ $I_K = 1mA \text{ to } 100mA$		0.2	0.5		0.2	0.5	$\Omega$

## Test Circuits

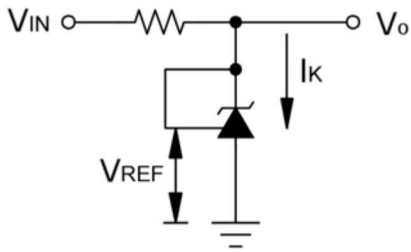

**Test Circuit 1.**  
 $V_{KA} = V_{REF}$

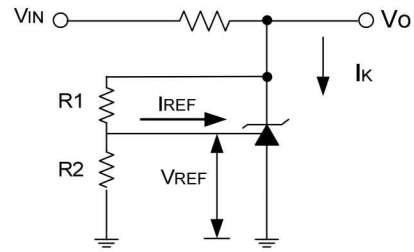

**Test Circuit 2.**  
 $V_{KA} > V_{REF}$

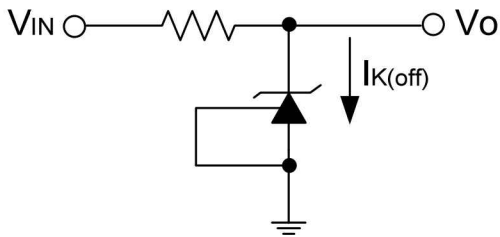

**Test Circuit 3.**  
Off-State Current

## Typical Performance Characteristics

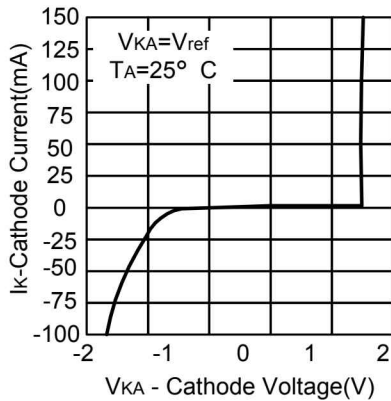

Cathode current vs. cathode voltage

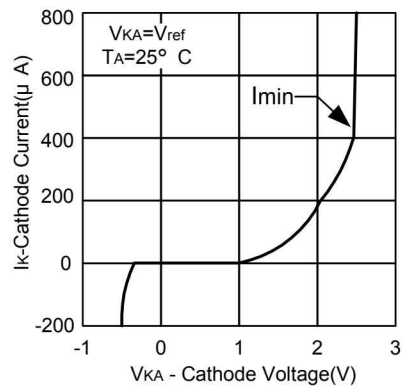

Cathode current vs. cathode voltage

## Stability Boundary Condition

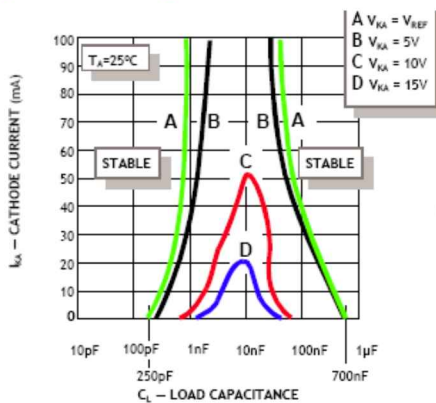

\*GS431 have not oscillation at  $V_{KA}=15V$  and  $V_{KA}=10V$



## SOT-89 PLASTIC PACKAGE

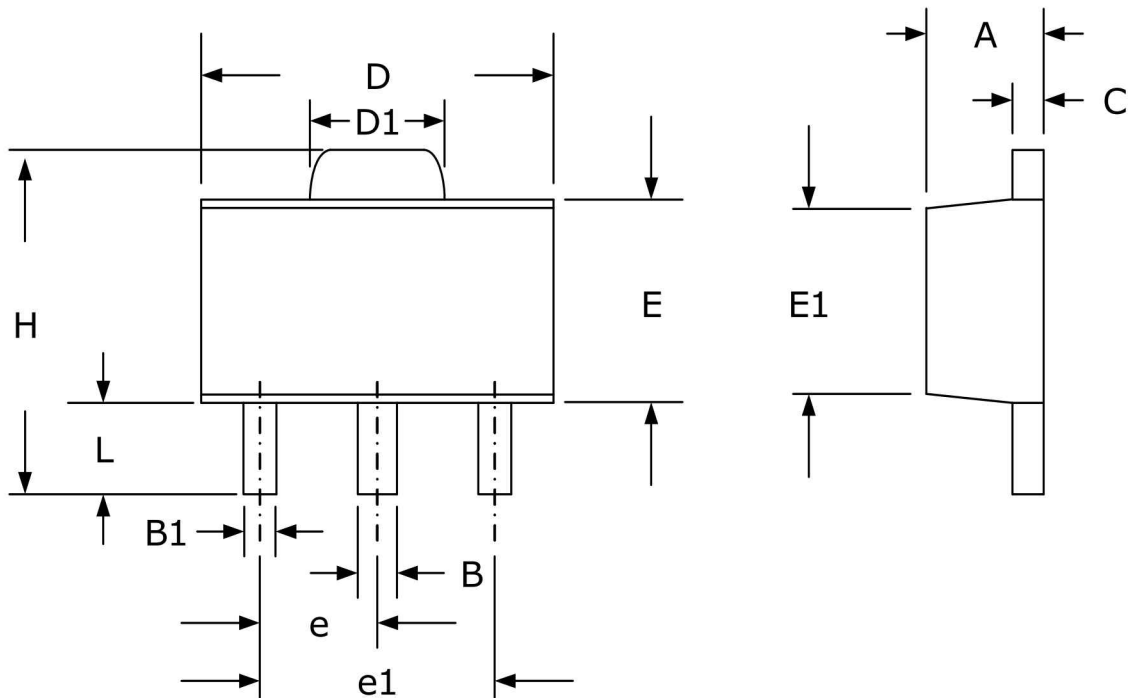

### Dimensions

SYMBOL	Millimeters		Inches	
	MIN	MAX	MIN	MAX
A	1.40	1.60	.055	.063
B	0.44	0.56	.017	.022
B1	0.36	0.48	.014	.019
C	0.35	0.44	.014	.017
D	4.40	4.60	.173	.181
D1	1.62	1.83	.064	.072
E	2.29	2.60	.090	.102
E1	2.13	2.29	.084	.090
e	1.50 (TYP)		.059 (TYP)	
e1	3.00 (TYP)		.118 (TYP)	
H	3.94	4.25	.155	.167
L	0.89	1.20	.035	.047

## SOT-23 PLASTIC PACKAGE

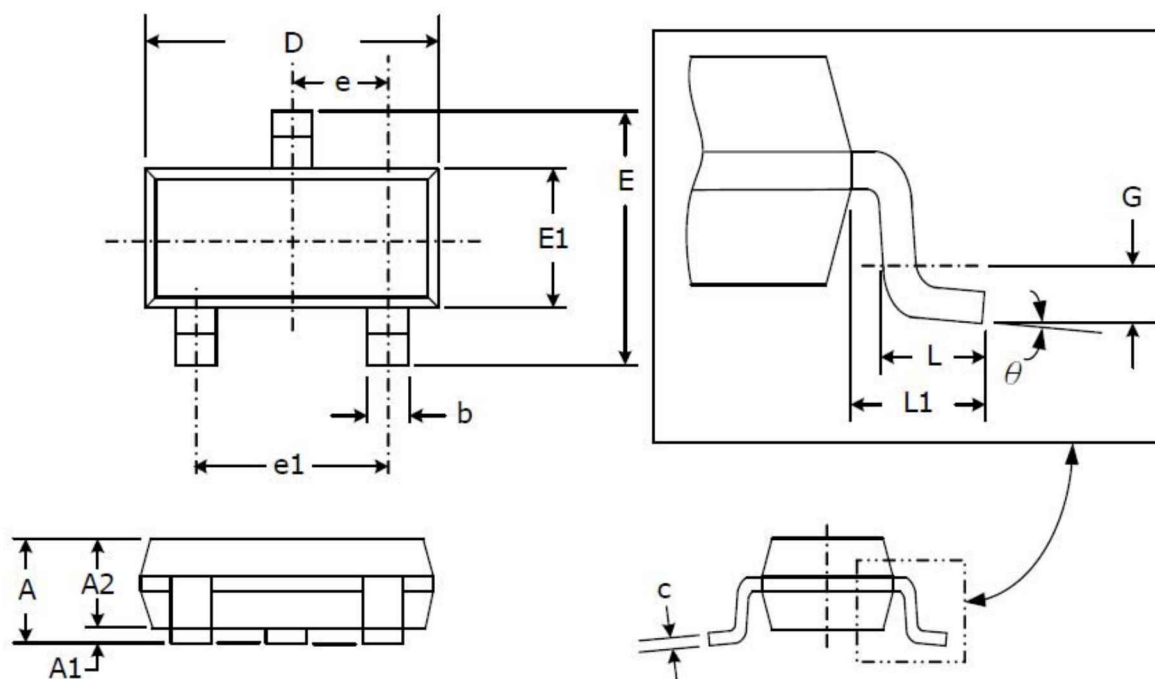

### Dimensions

SYMBOL	Millimeters		Inches	
	MIN	MAX	MIN	MAX
A	0.75	1.17	0.030	0.046
A1	0.05	0.15	0.002	0.006
A2	0.70	1.02	0.028	0.040
b	0.30	0.50	0.012	0.020
c	0.08	0.20	0.003	0.008
D	2.80	3.04	0.110	0.120
E	2.10	2.64	0.083	0.104
E1	1.20	1.40	0.047	0.055
e	0.95 (TYP)		0.037 (TYP)	
e1	1.90 (TYP)		0.075 (TYP)	
L	0.40	0.60	0.016	0.024
L1	0.54 (TYP)		0.021 (TYP)	
G	0.25 (TYP)		0.010 (TYP)	
θ	0°	8°	0°	8°



## SOT-23-3L PLASTIC PACKAGE

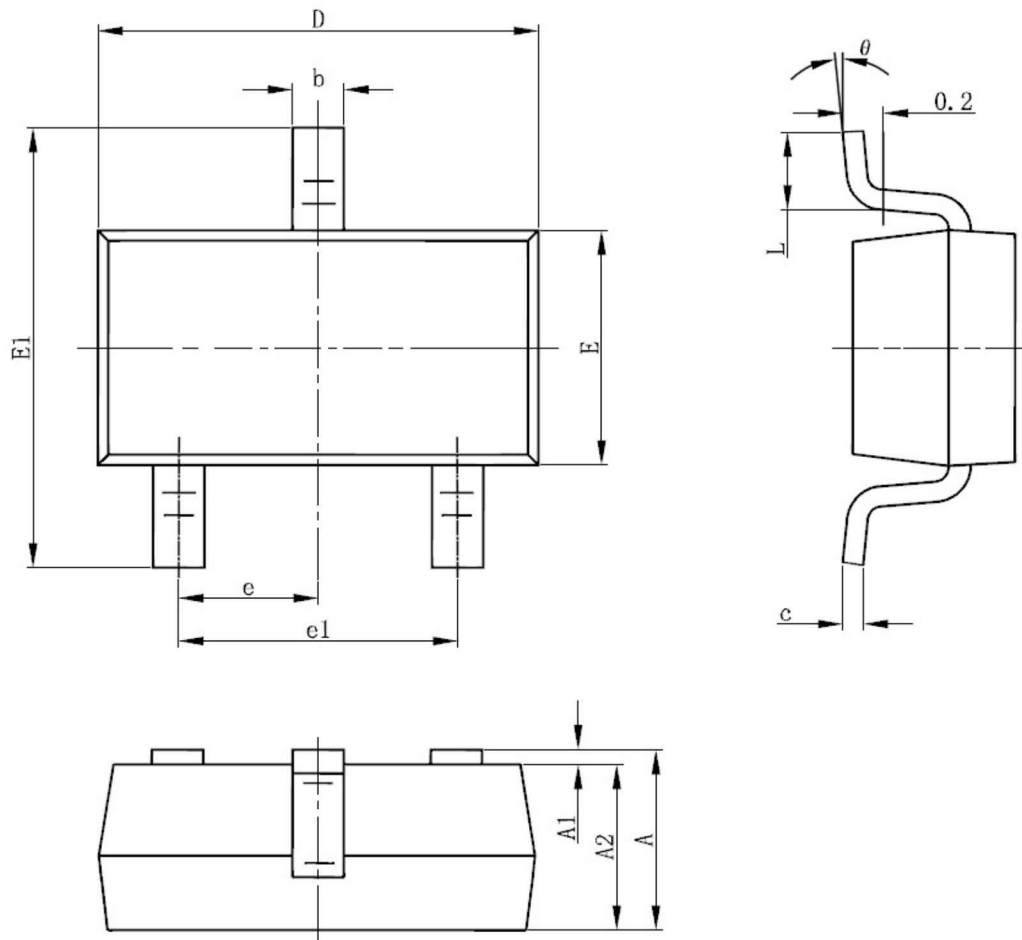

### Dimensions

SYMBOL	Millimeters		Inches	
	MIN	MAX	MIN	MAX
<b>A</b>	1.05	1.25	0.041	0.049
<b>A1</b>	0	0.1	0	0.004
<b>A2</b>	1.05	1.15	0.041	0.045
<b>b</b>	0.3	0.5	0.012	0.020
<b>c</b>	0.1	0.2	0.004	0.008
<b>D</b>	2.82	3.02	0.111	0.119
<b>E</b>	1.5	1.7	0.059	0.067
<b>E1</b>	2.65	2.95	0.104	0.116
<b>e</b>	0.950 (TYP)		0.037 (TYP)	
<b>e1</b>	1.8	2	0.071	0.079
<b>L</b>	0.3	0.6	0.012	0.024
<b>Q</b>	0°	8°	0°	8°

## TO-92 PLASTIC PACKAGE

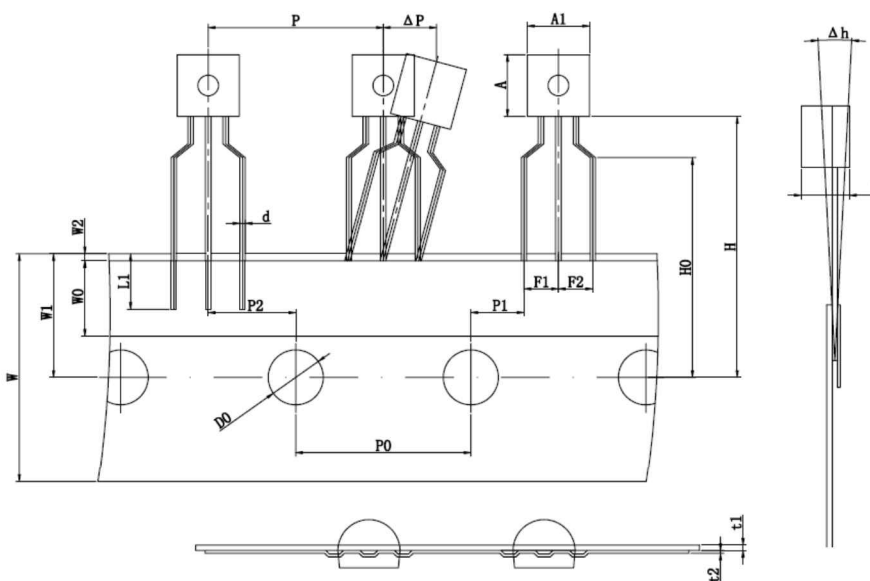





### Dimensions

SYMBOL	Millimeters		Inches	
	MIN	MAX	MIN	MAX
A1	4.4	4.6	.173	.181
A	4.4	4.6	.173	.181
T	3.4	3.6	.133	.142
d	.36	.40	.014	.016
P	12.4	13.0	.487	.512
P0	12.5	12.9	.491	.508
P2	6.05	6.65	.238	.262
F1,F2	2.2	2.8	.086	.110
Δh	-1.0	1.0	-.039	.039
W	17.5	19	.688	.748
W0	5.5	6.5	.216	.256
W1	8.5	9.5	.334	.374
W2	-	1	-	.039
H	19.	21	.747	.827
H0	15.5	16.5	.609	.650
L1	2.5	-	.098	-
D0	3.8	4.2	.149	.165
t1	.35	.45	.014	.018
t2	.15	.25	.006	.010
P1	3.55	4.15	.140	.163
ΔP	-1	1	-.039	.039

## NOTICE

Information furnished is believed to be accurate and reliable. However Globaltech Semiconductor assumes no responsibility for the consequences of use of such information nor for any infringement of patents or other rights of third parties, which may result from its use. No license is granted by implication or otherwise under any patent or patent rights of Globaltech Semiconductor. Specifications mentioned in this publication are subject to change without notice. This publication supersedes and replaces all information without express written approval of Globaltech Semiconductor.

## CONTACT US

GS Headquarter	
	4F.,No.43-1,Lane11,Sec.6,Minquan E.Rd Neihu District Taipei City 114, Taiwan (R.O.C)
	886-2-2657-9980
	886-2-2657-3630
	sales_twn@gs-power.com

Wu-Xi Branch	
	No.21 Changjiang Rd., WND, Wuxi, Jiangsu, China (INFO. & TECH. Science Park Building A 210 Room)
	86-510-85217051
	86-510-85211238
	sales_cn@gs-power.com

RD Division	
	824 Bolton Drive Milpitas. CA. 95035
	1-408-457-0587