



GPLB62X Series

8-bit LCD Controller/Driver with SPU

Jul 26, 2016

Version 1.8

Table of Contents

	<u>PAGE</u>
1. GPLB62X MASK ROM SERIES	4
2. GENERAL DESCRIPTION	4
3. BLOCK DIAGRAM	4
3.1. GPLB62X	4
4. FEATURES	4
5. APPICATION FIELD	5
6. SIGNAL DESCRIPTIONS	6
6.1. MAIN FUNCTION PIN	6
7. FUNCTIONAL DESCRIPTIONS	8
7.1. MEMORY	8
7.2. OPERATING STATES	8
7.2.1. Operating Mode	8
7.2.2. Standby Mode	8
7.2.3. Halt Mode	8
7.3. SPEECH AND MELODY, AND DAC	8
7.4. HARDWARE PWMIO	8
7.5. LCD CONTROLLER/DRIVER	8
7.6. LCD VOLTAGE GENERATOR	8
7.7. LCD SPRITE FUNCTION	8
7.8. USB DEVICE FUNCTION	8
7.9. LOW VOLTAGE DETECTION	9
7.10. WATCHDOG TIMER (WDT)	9
7.11. SPI CONTROLLER	9
8. ELECTRICAL SPECIFICATIONS	10
8.1. ABSOLUTE MAXIMUM RATINGS	10
8.2. DC CHARACTERISTICS (VDD_REGIN=4.5V, FOR 3-BATTERY APPLICATION, INTERNAL REGULATOR ENABLED OUTPUT, T _A =25°C)	10
8.3. DC CHARACTERISTICS(VDD_REGIN= 3.0V, FOR 2-BATTERY APPLICATION, INTERNAL REGULATOR OUTPUT DISABLED, T _A =25°C)	11
8.4. THE RELATIONSHIP BETWEEN THE R _{OSC} AND THE F _{OSC}	12
8.5. THE RELATIONSHIP BETWEEN THE R32K AND THE F32K	12
8.6. THE RELATIONSHIP BETWEEN THE F _{CPU} AND THE L _{OP}	12
8.7. DAC CHARACTERISTICS (VDD_REGIN = 5.0V, T _A = 25°C)	12
8.8. REGULATOR CHARACTERISTICS (T _A = 25°C)	12
9. APPLICATION CIRCUITS	14
9.1. 2368 DOTS LCD DRIVER, 74 SEGMENTS × 32 COMMONS, FOR 3-BATTERY APPLICATION, INTERNAL 3.3V REGULATOR ENABLED, ROSC24M XTAL32K SELECTED, PB[4:7] CONNECTED TO 3.3V SPI FLASH USING INTERNAL 3.3V REGULATOR POWER - (1)	14
9.2. 2368 DOTS LCD DRIVER, 74 SEGMENTS × 32 COMMONS, INTERNAL 3.3V REGULATOR DISABLED, FOR 2-BATTERY APPLICATION, SYSTEM PLL XTAL32K SELECTED - (2)	15
9.3. 4608 DOTS LCD, EXTENDED LCD DRIVER ENABLED, CONNECTED TO GPLD2080A, 144 SEGMENTS (INTERNAL 64 SEGMENTS + EXTERNAL 80 SEGMENTS) × 32 COMMONS, FOR 3-BATTERY APPLICATION, INTERNAL 3.3V REGULATOR ENABLED, XTAL24M ROSC32K SELECTED - (3)	16



9.4. 2560 DOTS LCD, EXTENDED LCD DRIVER ENABLED, CONNECTED TO GPLD2080A, 160 SEGMENTS (INTERNAL 80 SEGMENTS + EXTERNAL 80 SEGMENTS) × 16 COMMONS, FOR 3-BATTERY APPLICATION, INTERNAL 3.3V REGULATOR ENABLED, XTAL24M ROOSC32K SELECTED - (4).....	17
9.5. 6144 DOTS LCD, EXTENDED LCD DRIVER ENABLED, CONNECTED TO TWO GPLD2080A, 192 SEGMENTS (INTERNAL 48 SEGMENTS + EXTERNAL 144 SEGMENTS) × 32 COMMONS, FOR 3-BATTERY APPLICATION, INTERNAL 3.3V REGULATOR ENABLED, XTAL24M ROOSC32K SELECTED - (5).....	18
10. PACKAGE/PAD LOCATIONS	19
10.1. ORDERING INFORMATION	19
11. DISCLAIMER.....	20
12. REVISION HISTORY	21

8-BIT LCD CONTROLLER/DRIVER WITH SPU

1. GPLB62X MASK ROM SERIES

Product No.	GPLB62200UA	GPLB62150UA	GPLB62100UA	GPLB62200A	GPLB62150A
ROM size (M-byte)	2	1.5	1	2	1.5
Dedicated IOs	22	22	16	22	22
With USB	Yes	Yes	Yes	No	No

2. GENERAL DESCRIPTION

The GPLB62X, an 8-bit microprocessor for LCD handheld products, features 2560 bytes working RAM, 1536 bytes LCD RAM, 22 I/Os, two 16-bit timers, two SPI interfaces, a 14-bit DAC with push-pull amplifier for driving speaker directly and automatic display controller/ driver for mono/ 4-gray-level LCD.

In display features, GPLB62X contains up to 74 segments and 32 commons, forming a maximum of 2368 dots LCD resolution. In addition to the built-in driver function, the common/segment can be extended with external drivers such as GPLD2080A and GPLD2120A. The GPLB62X is capable of operating over a wide voltage, ranging from 2.3V through 5.5V. The Low Voltage Reset function keeps system operating properly when power drops below certain level..

The GPLB62X is equipped a high performance SPU voice engine to achieve 8-channel ADPCM/PCM high quality voice and one 14-bit DAC with push-pull amplifier for driving speaker directly. Its large memory area allows user to store both program and audio data in one place. The USB device function assures data transmitted in a high speed with reliability. A Serial Peripheral Interface (SPI) controller is embedded facilitate communication between devices. For more information about GPLB62X's feature, please refer to the following section.

3. BLOCK DIAGRAM

3.1. GPLB62X

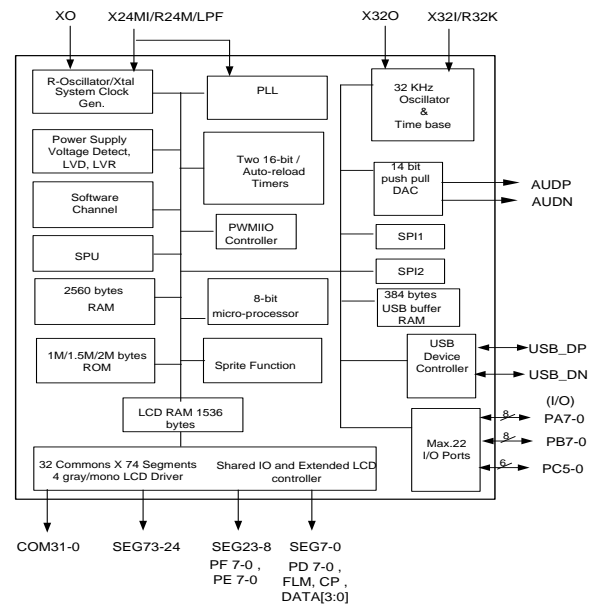

Note: The available ROM size and USB capability depend on the product selected. There's no PC5-0 in GPLB62100UA.

4. FEATURES

- 8-bit microprocessor
- 1 M, 1.5M or 2M bytes ROM
- 2560-byte SRAM
- 1536-byte LCD RAM
- Operating voltage: 2.3V – 5.5V
- Max. CPU operating speed:
 - 12.0MHz @ 2.7V – 5.5V
 - 8.0MHz @ 2.3V – 3.6V
- Programmable CPU clock: /2, /4, /8, /16, /32, /64 and /128 clock frequency
- Six wake-up sources
- 23 IRQs & 4 NMI Interrupts

- Internal built-in regulator to supply core power (3.3V, for 3-battery application). Also internal built-in regulator can be turned off and external 3.6V power is used to supply core power (for two-battery application).
- Supports USB 2.0 full speed (12MHz) compliant device with built-in transceiver
- SPU (Sound Processing Unit) engine with 8 voice channels
 - Supports 4/5 bit ADPCM and 8/16 bit PCM data format
 - Transforms 4/5 bit ADPCM data to 14 bit data to play high quality sound
 - Supports special tags e.g. Silence tag, Event tag
- One software channel with noise filter to play high quality sound.
- LCD sprite function
 - Supports special function such as PIP, data shift, and write back etc.
- Programmable LCD driver
 - Up to 74 segments and 32 commons, forming a maximum of 2368 (74x32) dots LCD resolution
 - The segment could be further extended with external drivers such as GPLD2080A and GPLD2120A.
 - Supports up to 32 x 192 gray level LCD panel with two GPLD2080.
 - Supports up to 32 x 384 mono level LCD panel with four GPLD2080.
 - Supports from 1/2 duty up to 1/32 duty
 - 1536 bytes dedicated LCD RAM
 - Supports normal type-B and type-C LCD waveform with or without key scan
 - Built-in voltage regulator to generate VLCD for LCD driver
 - 46-level contrast control (VLCD=3.5V~8V)
 - Power saving SLEEP mode
- Low Voltage Detector
 - 8-level (2.3V/2.4V/2.6V/2.9V/3.0V/3.3V/3.6V/4.0V) voltage detector with +- 5% variation
- Low Voltage Reset
- Peripherals
 - Max. 46 I/O pins (PA[7:0], PB[7:0], PC[5:0], PD[7:0], PE[7:0], PF[7:0])
 - Dedicated I/Os: PA[7:0], PB[7:0], PC[5:0]
 - Shared pin I/Os:
 - PD[3:0]/SEG[3:0]/LCDDI[3:0]
 - PD[4]/SEG[4]/LCDCP
 - PD[5]/SEG[5]/LCDLP
 - PD[6]/SEG[6]/LCDDM
 - PD[7]/SEG[7]/LCDFLM
 - PE[7:0]/SEG[15:8]
 - PF[7:0]/SEG[23:16]
 - Eight I/Os with high sink current for LED application
 - Key wakeup/interrupt function
 - Built-in 32.768KHz oscillator circuit for real time clock function (X'tal or R-osc)
 - Built-in R-oscillator (external resistor is needed) or X'tal or PLL for system operating clock
 - Internal time base generator
 - Two 16-bit reloadable timer/counters
 - Watchdog timer
 - 14-bit DAC with push-pull amplifier for driving speaker directly
 - IR output
 - Hardware PWMIO
 - Two SPI serial interface I/Os
- Powerful 8-ch Sound Processing Unit (SPU)
 - Variable tone-color sampling rate: max = 96KHz @ SPU_clock = 24MHz
 - 8-voice polyphony
 - Supports PCM/ADPCM tone-color table

5. APPLICATION FIELD

- Handheld LCD game
- Educational toys (Electronic Learning Aids)
- Data bank
- Dictionary
- Translator

6. SIGNAL DESCRIPTIONS

6.1. Main Function PIN

Mnemonic	PIN No.	Type	Description
SEG0 / PD0 / LCDDI0	61	O	LCD driver segment output. SEG0 shared pin with PD0 and LCDDI0
SEG1 / PD1 / LCDDI1	60	O	LCD driver segment output. SEG1 shared pin with PD1 and LCDDI1
SEG2 / PD2 / LCDDI2	59	O	LCD driver segment output. SEG2 shared pin with PD2 and LCDDI2
SEG3 / PD3 / LCDDI3	58	O	LCD driver segment output. SEG3 shared pin with PD3 and LCDDI3
SEG4 / PD4 / LCDCP	57	O	LCD driver segment output. SEG4 shared pin with PD4 and LCDCP
SEG5 / PD5 / LCDLP	56	O	LCD driver segment output. SEG5 shared pin with PD5 and LCDLP
SEG6 / PD6 / LCDM	55	O	LCD driver segment output. SEG6 shared pin with PD6 and LCDM
SEG7 / PD7 / LCDFLM	54	O	LCD driver segment output. SEG7 shared pin with PD7 and LCDFLM
SEG15 - 8 / PE7-0	38~53	O	LCD driver segment output. SEG15 - 8 shared pin with PE7-0
SEG23 - 16 / PF7-0	37~44	O	LCD driver segment output. SEG23 - 16 shared pin with PF7-0
SEG73 - 24	152~165, 1~29, 31~37	O	LCD driver segment output.
COM16-31 / SEG89-74	135~150	O	LCD driver segment output shared with comment output.
COM0- 15	77~62	O	LCD driver common output.
PA0 / IRO / EXT1	96	I/O	PA0 is a bi-directional I/O port, which can be software programmed as wakeup I/O and is shared with IRO (IR output) and external interrupt 1.
PA1 / EXT2	95	I/O	PA1 is a bi-directional I/O port, which can be software programmed as wakeup I/O and is shared with external interrupt 2.
PA3 - 2	93, 94	I/O	PA3-2 is a bi-directional I/O port, which can be software programmed as wakeup I/O.
PA4 / PWMIO0	92	I/O	PA4 is a bi-directional I/O port, which can be software programmed as wakeup I/O and is shared with PWMIO0.
PA5 / PWMIO1	91	I/O	PA5 is a bi-directional I/O port, which can be software programmed as wakeup I/O and is shared with PWMIO1.
PA6 / PWMIO2	90	I/O	PA6 is a bi-directional I/O port, which can be software programmed as wake up I/O and is shared with PWMIO2.
PA7 / PWMIO3	89	I/O	PA7 is a bi-directional I/O port, which can be software programmed as wakeup I/O and is shared with PWMIO3.
PB0 / SPI2_CSN / IISCKO	87	I/O	PB0 is shared with SPI2_CSN and IISCKO
PB1 / SPI2_SCK / IISDAO	86	I/O	PB1 is shared with SPI2_SCK and IISDAO
PB2 / SPI2_SDO / IISWSO	85	I/O	PB2 is shared with SPI2_SDO and IISWSO
PB3 / SPI2_SDI	84	I/O	PB3 is shared with SPI2_SDI.
PB4 / SPI1_CSN / PWMIO0	82	I/O	PB4 is shared with SPI1_CSN and shared with PWMIO0 and is a high driving IO.
PB5 / SPI1_SCK / PWMIO1 / IISCKI	81	I/O	PB5 is shared with SPI1_SCK and IISCKI and shared with PWMIO1 and is a high driving IO.
PB6 / SPI1_SDO / PWMIO2 / IISDAI	80	I/O	PB[6:5] is shared with SPI1_SDO and IISDAI and shared with PWMIO2 and is a high driving IO.
PB7 / SPI1_SDI / PWMIO3 / IISWSI	79	I/O	PB7 is shared with SPI1_SDI and IISWSI and shared with PWMIO3 and is a high driving IO.
PC0 -5 (NC)	102~97	I/O	PC[0:5] is a bi-directional I/O port(All NC pin in GPLB62100UA)
X24MI / R24M / LPF	109	I	Crystal input or ROSC input connected to VDD33V_REGOUT through a resistor, or RC low pass filter connection for PLL(Mask option).

Mnemonic	PIN No.	Type	Description
X24MO	108	O	Crystal output
RESETB	103	I	System reset input, low active, internal pull high.
AUDP, AUDN	113, 117	O	Audio output of push pull DAC
X32I / R32K	110	I	32.768KHz crystal input or connects to VDD33V_REGOUT through a resistor (option).
X32O	111	O	32.768KHz crystal output
TEST	104	I	Test input, internal pull low
CAP1P, CAP1N	125, 126	P	LCD voltage generation, charge pump capacitor interconnection pins.
CAP2P, CAP2N	127, 128	P	LCD voltage generation, charge pump capacitor interconnection pins.
LCDVPP	129	P	LCD voltage generation, voltage generated by charge pump.
V4	131	P	LCD voltage generation
V3	132	P	LCD voltage generation
V2	133	P	LCD voltage generation
V1	134	P	LCD voltage generation
VLCD	130	P	LCD voltage generation, the highest voltage for LCD display.
VDD_REGIN	106	P	Power for Regulator
VSS	105	P	Ground for Regulator
VDD33V_REGOUT	107	P	3.3V power output from regulator (regulator can be off when external 3V is supplied).
VDD_LCD	123	P	Power for LCD driver
VSS_LCD	30, 124, 151	P	Ground for LCD driver
VDD_IO	88	P	Power for PA, PC, PD, PE, PF
VSS_IO	83	P	Ground for PA, PB, PC, PD, PE, PF
VDD_PB	78	P	Power for PB
VDD_DAC	118	P	Power for push pull DAC driver
VSS_DAC	116	P	Ground for push pull DAC driver
AVDD_DAC	122	P	Analog ground for push pull DAC
AVSS_DAC	121	P	Analog power for push pull DAC
USB_DP(NC)	113	I/O	USB_DP pin of USBPHY(NC pin if without USB)
USB_DM(NC)	114	I/O	USB_DN pin of USBPHY(NC pin if without USB)
VDD33V_USB(VDD33V)	112	P	Power for USB(VDD33V pin if without USB)
VSS_USB(NC)	115	P	Ground for USB(NC pin if without USB)

Legend: I = Input, O = Output, P = Power

7. FUNCTIONAL DESCRIPTIONS

7.1. Memory

GPLB62X contains 2560-byte SRAM, 1536-byte LCD RAM and works with 1M, 1.5M or 2M bytes ROM.

7.2. Operating States

There are three operation modes involved in GPLB62X: standby, halt and operating. The following table shows the differences between these modes.

	Operating	Halt	Standby
CPU	ON	OFF	OFF
32768Hz Oscillator	ON	ON	OFF
LCD Driver	ON	ON/OFF	OFF

7.2.1. Operating Mode

In operating state, all functions (CPU, 32768Hz oscillator, timer/counter, LCD driver...) are activated.

7.2.2. Standby Mode

Turn off 32768Hz oscillator and write "07H" to P_CLK_CPU_Ctrl Register (\$3006) to activate standby mode. The standby mode is a mode that the device is placed in its lowest current consumption state. In standby mode, all functions are turned off; in addition, RAM and I/Os will retain at their previous states.

7.2.3. Halt Mode

Write "07H" to P_CLK_CPU_Ctrl Register (\$3006) to enter halt mode, but it still keeps 32768Hz oscillator running. In halt mode, CPU clock halts and waits for an event (e.g. key press, timer overflow) to wake up. The 32768Hz related functions, such as timer/counter and LCD driver, may remain active in the halt mode.

The following figure is the GPLB62X state diagram:

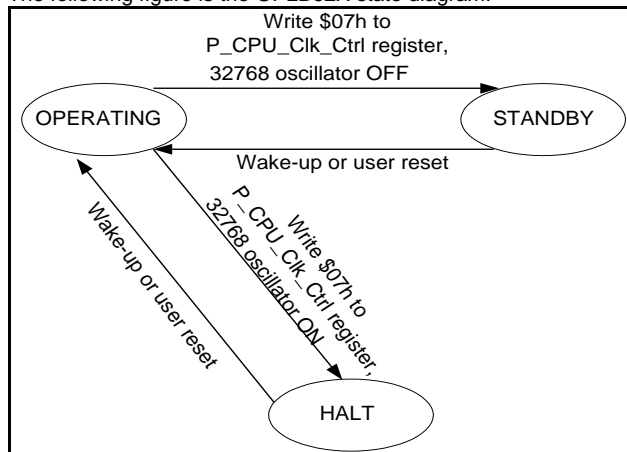

GPLB62X State Diagram

7.3. Speech and Melody, and DAC

The GPLB62X uses a high performance SPU voice engine to archive 8-channel voice with ADPCM/PCM code. The SPU also supports automatic zero-crossing concatenating function. A hardware multiplier is also embedded in this SPU for software use. The fixed addresses of RAM area \$0000 - \$009F is designed as address pointers and a data buffer for the 8-channel speech/melody generation. Moreover, one 14-bit software channel with noise filter is also supported. There is one 14-bit DAC with push-pull amplifier for direct audio output.

7.4. Hardware PWMIO

Hardware PWMIO supports four LED outputs with 256 brightness levels. The clock source of PWMIO can be selected by user's request.

7.5. LCD Controller/Driver

GPLB62P200UA has a built-in LCD driver and support monochrome and four gray LCD controls. The LCD driver can support up to 32COM * 74SEG, and it also can cascade external LCD SEG driver that can extend LCD resolution up to 32COM * 192SEG with gray level or up to 32COM * 384SEG with mono level. Programmers are able to define the LCD configuration by setting up the LCD Control Register. Once the LCD configuration is completed, the desired pattern can be displayed by filling the LCD buffer with proper data. The LCD driver can also operate in halt mode by keeping 32768Hz oscillator running. The LCD driver in GPLB62P200UA supports 1/2 – 1/32 duty and 1/3 - 1/7 bias.

7.6. LCD Voltage Generator

To achieve highly integrated circuit and save external components, GPLB62X has built-in charge-pump circuit to generate LCD's bias voltages VLCD, V4, V3, V2 and V1. The level of VLCD can be adjusted by software. It is suggested that VLCD must be higher than VDD_IO or abnormal operation will occur.

7.7. LCD Sprite Function

The GPLB62X also supports special functions such as PIP, data shift, and write back, etc. User can implement sprite function easily.

7.8. USB Device Function

The GPLB62X provides the device function which is compatible with USB 2.0 full-speed standard. An USB transceiver is also built-in.

7.9. Low Voltage Detection

The GPLB62X equips an 8-level (Software programmable) low voltage detector to detect low voltage events. Users can turn on the low voltage detection that monitors VDD_REGIN periodically to check whether it is lower than the given value. In addition, if LV NMI is enabled, an NMI will be issued to notify CPU if power voltage drops below the given value. Also, the voltage detector will generate a system reset if power supply voltage drops too low.

7.10. Watchdog Timer (WDT)

An on-chip watchdog timer is also available in the GPLB62X. The WDT is designed to recover the system from unexpected operations. In some cases, if WDT is not cleared within one second, the WDT will generate a system reset to restart system. If WDT is enabled, the WDT should be cleared periodically to avoid accidental reset. The WDT can be cleared through software programming. Note that the WDT works only when 32768Hz clock is activated.

7.11. SPI Controller

Two Serial Peripheral Interface (SPI) controllers are built-in to enable synchronous serial communication with master/slave peripherals. There are four control signals on SPI including SPICSN, SPICLK (SCK), SPIRX (SDI), and SPITX (SDO). The four signals of SPI1 are shared with PB4, PB5, PB6 and PB7. The four SPI2 signals are shared with PB0, PB1, PB2, and PB3. While SPI module is enabled by corresponding control bit, these four pins cannot be used as GPIOs and any setting on corresponding GPIO control register will have no effect. Four types of operating modes are supported as follows:

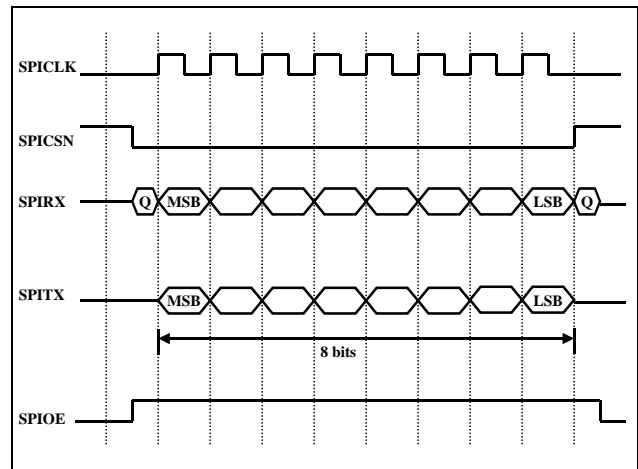

Master Mode, Polarity = 0, Phase=1

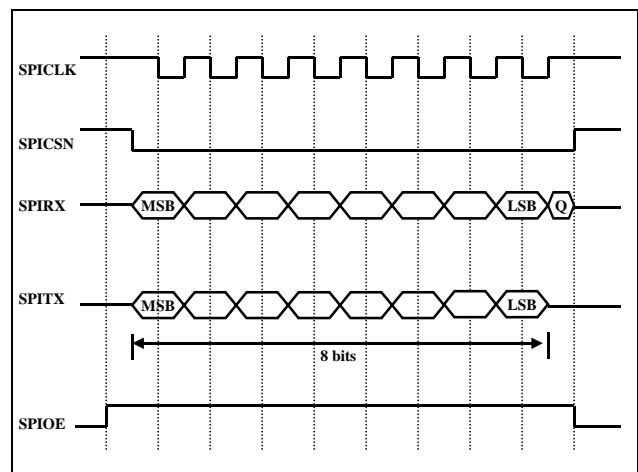

Master Mode, Polarity = 1, Phase=0

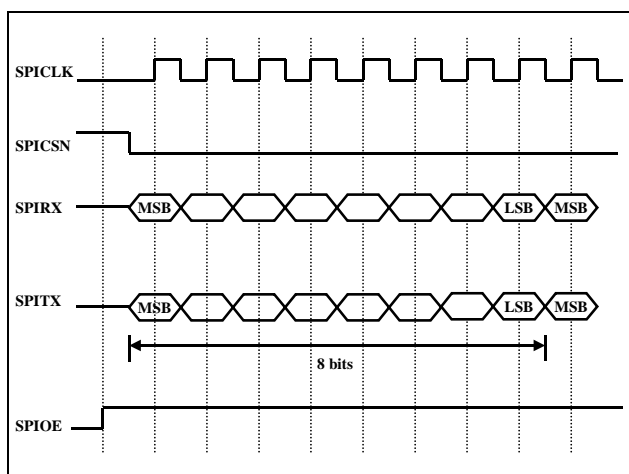

Master Mode, Polarity = 0, Phase=0

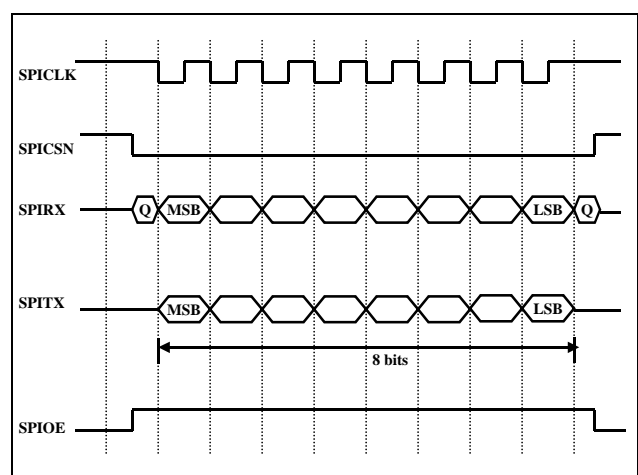

Master Mode, Polarity = 1, Phase=1

8. ELECTRICAL SPECIFICATIONS

8.1. Absolute Maximum Ratings

Characteristics	Symbol	Ratings
DC Supply Voltage	V_+	< 7.0V
Input Voltage Range	V_{IN}	-0.5V to $V_+ + 0.5V$
Operating Temperature	T_A	0°C to +70°C
Storage Temperature	T_{STO}	-50°C to +150°C

Note: Stresses beyond those given in the Absolute Maximum Rating table may cause permanent damage to the device. For normal operational conditions see AC/DC Electrical Characteristics.

8.2. DC Characteristics (VDD_REGIN=4.5V, for 3-battery Application, Internal Regulator Enabled Output, $T_A=25^\circ\text{C}$)

Characteristics	Symbol	Limit			Unit	Test Condition
		Min.	Typ.	Max.		
Operating Voltage	VDD_REGIN	2.7	-	5.5	V	For 3-battery
Operating Current	I_{OP1}	-	7	9	mA	$F_{CPU} = 8.0\text{MHz @ } 5.0V$ $F_{XTAL} = 16.0\text{MHz}$, no load, DAC disabled.
	I_{OP2}	-	10	13	mA	$F_{CPU} = 12.0\text{MHz @ } 5.0V$ $F_{ROSC} = 24.0\text{MHz}$, no load, DAC disabled.
Halt Current1	I_{HALT1}	-	15	22	μA	VDD_REGIN = 4.5V, 32K X'tal ON, Strobe off, LCD OFF
Halt Current2	I_{HALT2}	-	46	70	μA	VDD_REGIN = 4.5V, 32K X'tal ON, Strobe off, LCD ON, 1/7 Bias, VLCD=7.1 V, no LCD panel
Standby Current (Regulator on)	I_{STBYR}	-	-	10	μA	VDD_REGIN = 4.5V, internal regulator on, all off.
Input High Level	V_{IH}	0.7VDD_IO	-	VDD_IO	V	
Input Low Level(PA/PB/PC) (PD/PE/PF)	V_{IL}	0	-	0.3 VDD_IO	V	
Output High Current (I/O) PA/PB4~PB7 PB0~PB3/PC PD/PE/PF	I_{OH1} I_{OH2} I_{OH3}	9.8 7 3.5	14 10 5	18.2 13 6.5	mA	VDD_IO = 4.5V, $V_{OH} = 3.15V$
Output Low Current (I/O) PA4~PA7 PB4~PB7 PA0~PA3/PB0~PB3 PD/PE/PF	I_{OL1} I_{OL2} I_{OL3} I_{OL4}	25 18 6.3 3.5	50 36 9 5	75 54 11.7 6.5	mA	VDD_IO = 4.5V, $V_{OL} = 1.35V$
Input Pull-Low Resistor PA(weak pull) PA(strong pull) PB~PF	R_{PL}	100 35 35	150 50 50	200 65 65	$K\Omega$	$V_{IN} = 4.5V$
Input Pull-High Resistor PA(weak pull) PA(strong pull) PB,PC	R_{PH}	100 35 35	150 50 50	200 65 65	$K\Omega$	$V_{IN} = 0V$

Characteristics	Symbol	Limit			Unit	Test Condition
		Min.	Typ.	Max.		
LCD Driver Voltage ($V_{LCD} - V_{SS}$)	V_{LCD}	0.97 V_{LCD}	V_{LCD}	1.03 V_{LCD}	V	$V_{DD_REGIN} = 4.5V$, no load $V_{LCD,min} = 3.5V$ $V_{LCD,max} = 8V$
OSC Frequency	F_{osc}	22.3	24	25.7	MHZ	$R_{osc} = 23K\Omega$
OSC32K Frequency	F_{osc32k}	30474	32768	35061	HZ	$R_{osc32k} = 3M\Omega$

Note: V_{LCD} should be higher than V_{DD_IO} to prevent abnormal functions.

8.3. DC Characteristics($V_{DD_REGIN} = 3.0V$, for 2-battery Application, Internal Regulator Output Disabled, $T_A = 25^\circ C$)

Characteristics	Symbol	Limit			Unit	Test Condition
		Min.	Typ.	Max.		
Operating Voltage	V_{DD_REGIN}	2.3	-	3.6	V	For 2-battery
Operating Current	I_{OP1}	-	6	8	mA	$F_{CPU} = 8.0MHz @ 3.0V$ $F_{XTAL} = 16.0MHz$, no load, DAC disabled.
	I_{OP2}	-	7	9	mA	$F_{CPU} = 12.0MHz @ 3.0V$ $F_{ROSC} = 24.0MHz$, no load, DAC disabled.
Halt Current1	I_{HALT1}	-	8	12	μA	$V_{DD_REGIN} = 3.3V$, 32K X'tal ON, Strobe off, LCD OFF
Halt Current2	I_{HALT2}	-	35	65	μA	$V_{DD_REGIN} = 3.3V$, 32K X'tal ON, Strobe off, LCD ON, 1/7 Bias, $V_{LCD} = 7.06V$, no LCD panel
Standby Current (Regulator off)	I_{STBY}	-	1	5	μA	$V_{DD_REGIN} = 3.0V$, all off
Input High Level(PA/PB/PC) (PD/PE/PF)	V_{IH}	0.7 V_{DD_IO}	-	V_{DD_IO}	V	
Input Low Level(PA/PB/PC) (PD/PE/PF)	V_{IL}	0	-	0.3 V_{DD_IO}	V	
Output High Current (I/O) PA/PB4~PB7 PB0~PB3/PC PD/PE/PF	I_{OH1}	4.9	7	9.1	mA	$V_{DD_IO} = 3.0V$, $V_{OH} = 2.1V$
	I_{OH2}	3.5	5	6.5		
	I_{OH3}	1.8	2.5	3.3		
Output Low Current (I/O) PA4~PA7 PB4~PB7 PA0~PA3/PB0~PB3 PD/PE/PF	I_{OL1}	13	26	39	mA	$V_{DD_IO} = 3.0V$, $V_{OL} = 0.9V$
	I_{OL2}	10	20	30		
	I_{OL3}	3.5	5	6.5		
	I_{OL4}	2.1	3	3.9		
Input Pull-Low Resistor PA(weak pull) PA(strong pull) PB~PF	R_{PL}	100	150	200	$K\Omega$	$V_{IN} = 3.0V$
		35	50	65		
		35	50	65		
Input Pull-High Resistor PA(weak pull) PA(strong pull) PB,PC	R_{PH}	100	150	200	$K\Omega$	$V_{IN} = 0V$
		35	50	65		
		35	50	65		

Characteristics	Symbol	Limit			Unit	Test Condition
		Min.	Typ.	Max.		
LCD Driver Voltage ($V_{LCD} - VSS$)	V_{LCD}	0.97 V_{LCD}	V_{LCD}	1.03 V_{LCD}	V	$VDD_{IO} = 3.0V$ $V_{LCD,min} = 3.5V$ $V_{LCD,max} = 8V$
OSC Frequency	Fosc	22.3	24	25.7	MHZ	Rosc=23 K Ω
OSC32K Frequency	Fosc32k	30474	32768	35061	HZ	Rosc32k=3 M Ω

Note: V_{LCD} should be higher than VDD to prevent abnormal functions.

8.4. The Relationship between the R_{OSC} and the F_{OSC}

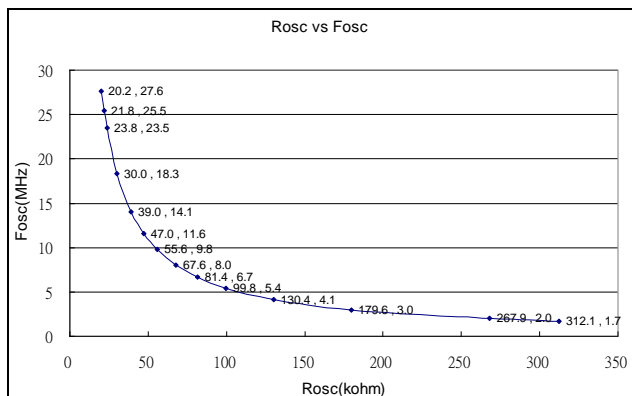

8.6. The Relationship between the F_{CPU} and the L_{OP}

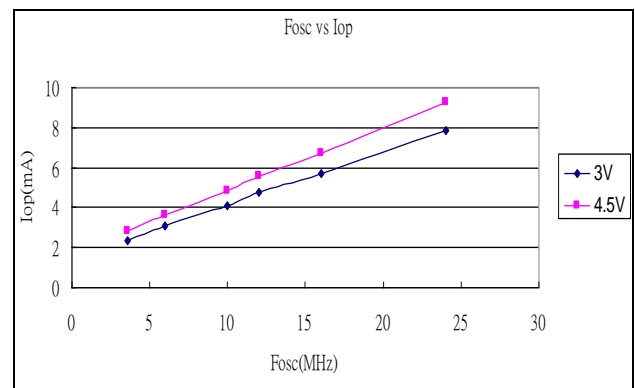

8.5. The Relationship between the R_{32K} and the F_{32K}

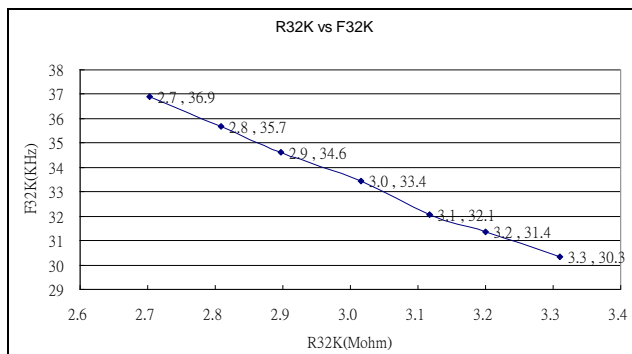

8.7. DAC Characteristics ($VDD_{REGIN} = 5.0V, TA = 25^{\circ}C$)

Characteristics	Symbol	Limit			Unit
		Min.	Typ.	Max.	
DAC Resolution	RESO	-	-	14	bit
THD+n (5V@0.6W)	-	-	1	-	%
Noise at No Signal	-	-	-97	-	dBr A
Dynamic Range(-60dB)	-	-	-66	-	dBr A

8.8. Regulator Characteristics ($TA = 25^{\circ}C$)

Characteristics	Symbol	Limit			Unit	Test Condition
		Min.	Typ.	Max.		
Input Voltage	VREGI	2.3	-	5.5	V	
Maximum Current Output	IREGO45	-	-	60	mA	$VDD5V$ (Regulator in) = 4.5V, ΔVDD (Regulator out) < 100mV

Characteristics	Symbol	Limit			Unit	Test Condition
		Min.	Typ.	Max.		
Maximum Current Output	IREGO ₃₀	-	-	60	mA	VDD5V (Regulator in) = 3.0V, Δ VDD (Regulator out) <300mV
Output Voltage	VREGO	3.135	3.3	3.465	V	VREGI > 3.5V
Standby Current	IRGES	-	2.5	-	uA	No load

Regulator driving current 30mA:

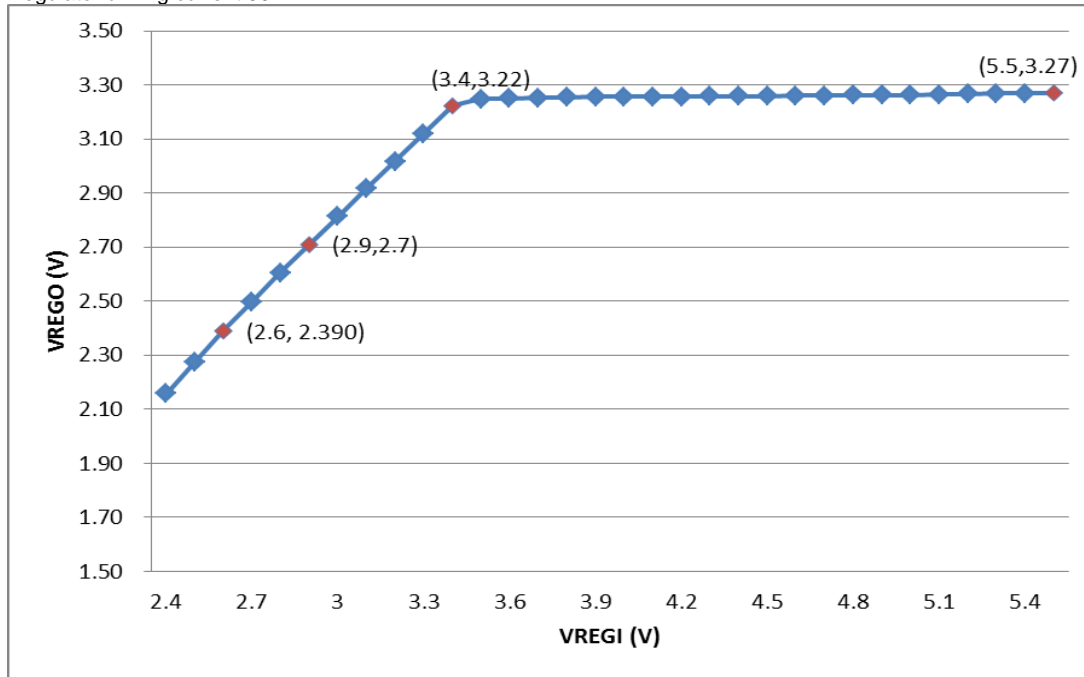

Regulator driving current 60mA:

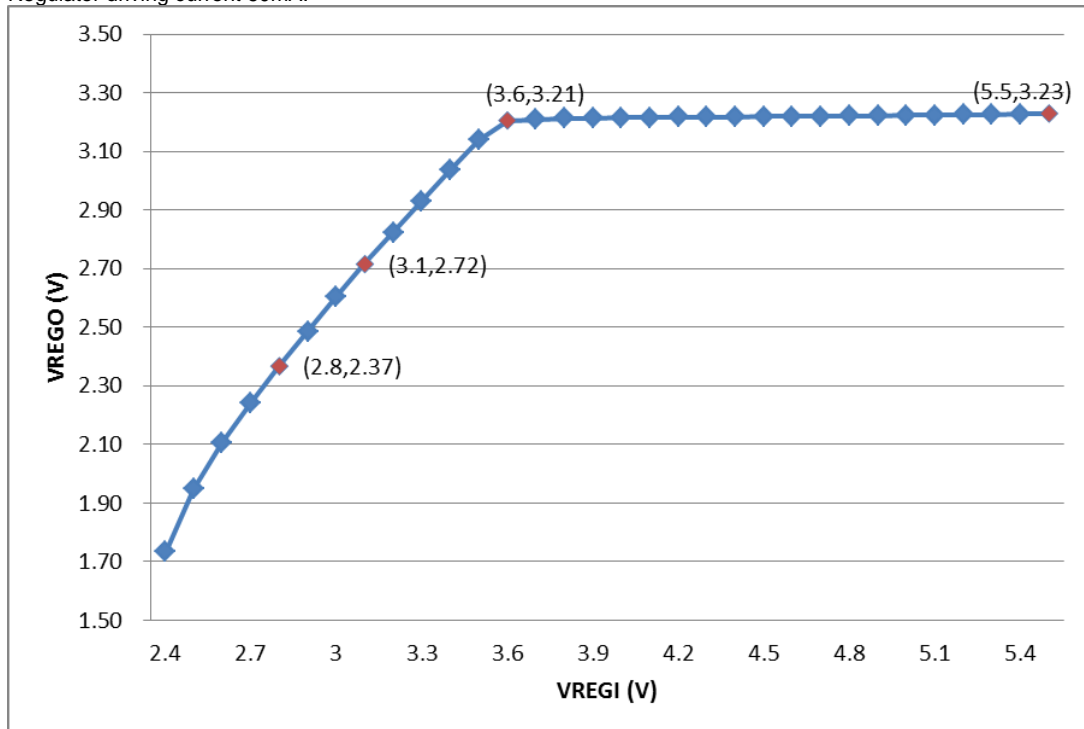

9.2. 2368 Dots LCD Driver, 74 Segments × 32 Commons, Internal 3.3V Regulator Disabled, for 2-battery Application, System PLL XTAL32K Selected - (2)

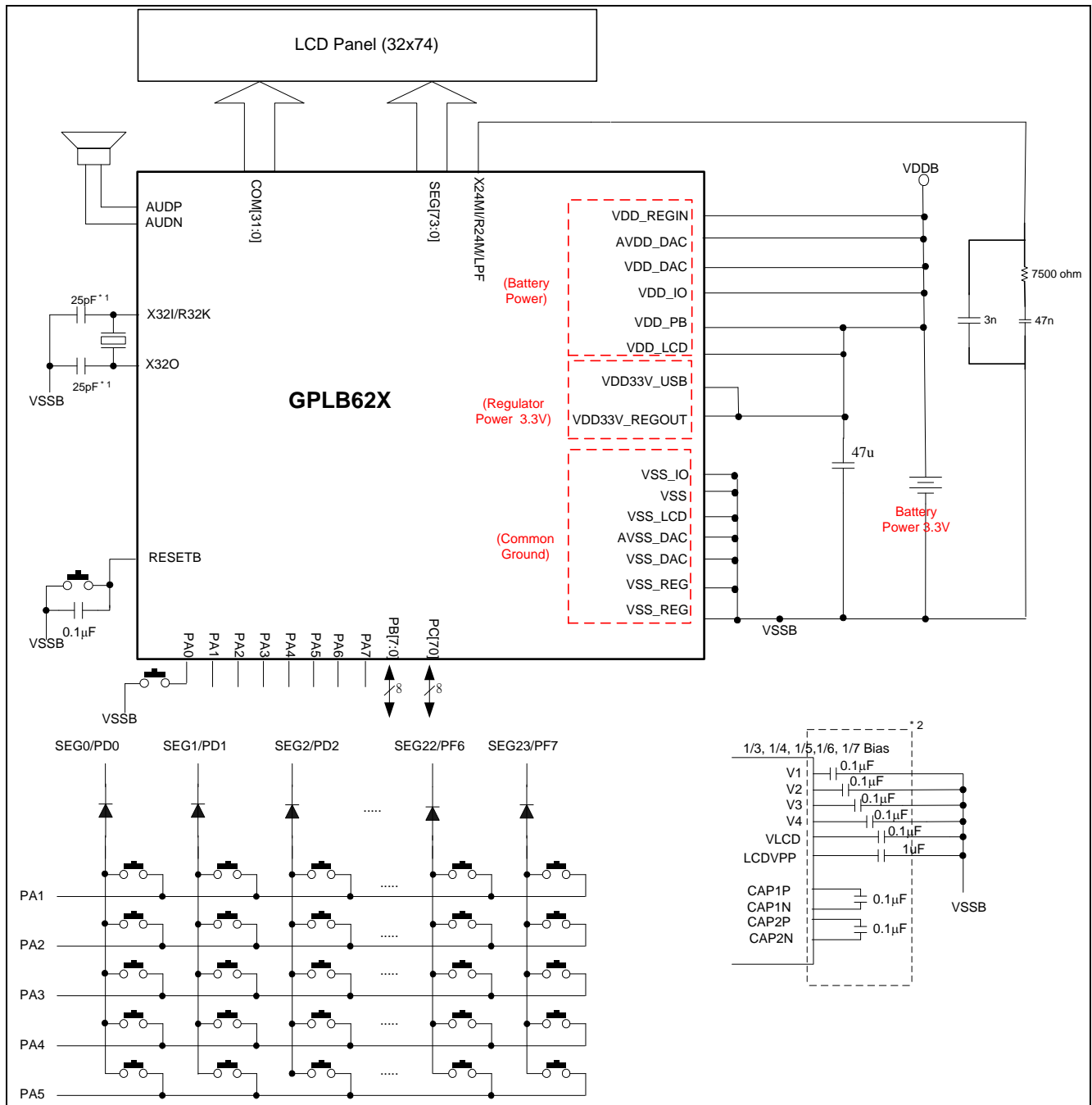

Note*1: These capacitor values are for design guidance only. The recommended 32K XTAL features are ESR=11.2~60K and CL1=CL2 =26~36pF (including PCB parasitic loading, for example, user should apply additional 20~30pF on X32I and X32O if PCB parasitic loading is 6pF)

Note*2: These capacitor values are for design guidance only. The ratio of LCDVPP capacitance to CAP1N/CAP1P/CAP2N/CAP2P capacitance is recommended to be 10:1. Generally, capacitance of VLCD and V1~V4 is 0.1uF and cannot be larger than capacitance of LCDVPP. But for larger LCD panel, the followings are recommended: 1uF capacitance for VLCD and V1~V4, 2.2uF capacitance for LCDVPP and 0.22uF capacitance for CAP1P/CAP1N/CAP2P/CAP2N.

9.3. 4608 Dots LCD, Extended LCD Driver Enabled, Connected to GPLD2080A, 144 Segments (Internal 64 Segments + External 80 Segments) x 32 Commons, for 3-battery Application, Internal 3.3V Regulator Enabled, XTAL24M ROSC32K Selected - (3)

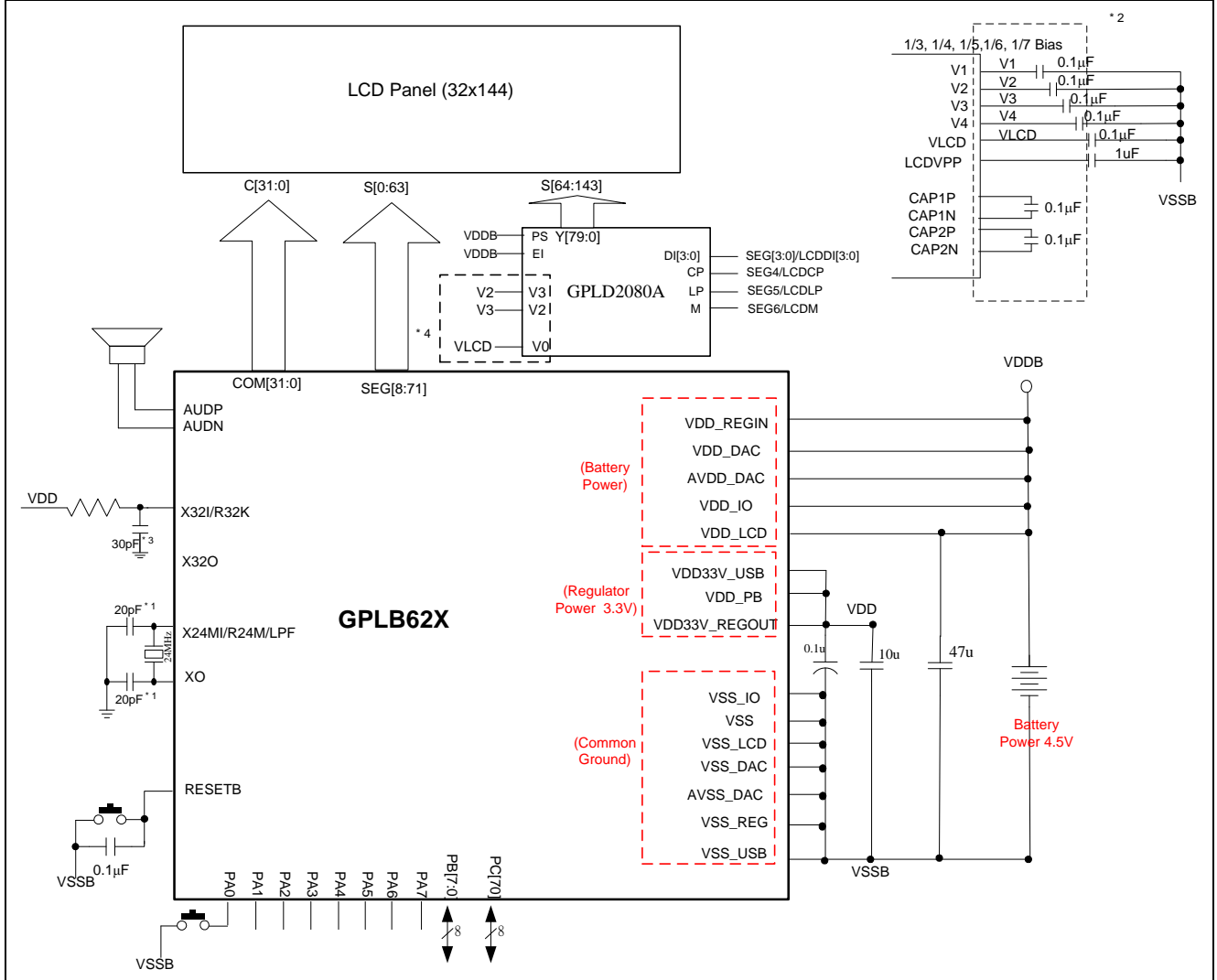

- Note*1:** These capacitor values are for design guidance only. Different capacitor values may be required for different crystal/resonator used.
- Note*2:** These capacitor values are for design guidance only. The ratio of LCDVPP capacitance to CAP1N/CAP1P/CAP2N/CAP2P capacitance is recommended to be 10:1. Generally, capacitance of VLCD and V1~V4 is 0.1uF and cannot be larger than capacitance of LCDVPP. But for larger LCD panel, the followings are recommended: 1uF capacitance for VLCD and V1~V4, 2.2uF capacitance for LCDVPP and 0.22uF capacitance for CAP1P/CAP1N/CAP2P/CAP2N.
- Note*3:** This capacitor can be removed if this node is immunized from noise.
- Note*4:** Please pay extra attention to the LCD power pin connection. GPLB62X's VLCD connects to GPLD2080A's V0. GPLB62X's V3 connects to GPLD2080A's V2. GPLB62X's V2 connects to GPLD2080A's V3.

9.4. 2560 Dots LCD, Extended LCD Driver Enabled, Connected to GPLD2080A, 160 Segments (Internal 80 Segments + External 80 Segments) × 16 Commons, for 3-battery Application, Internal 3.3V Regulator Enabled, XTAL24M ROSC32K Selected - (4)

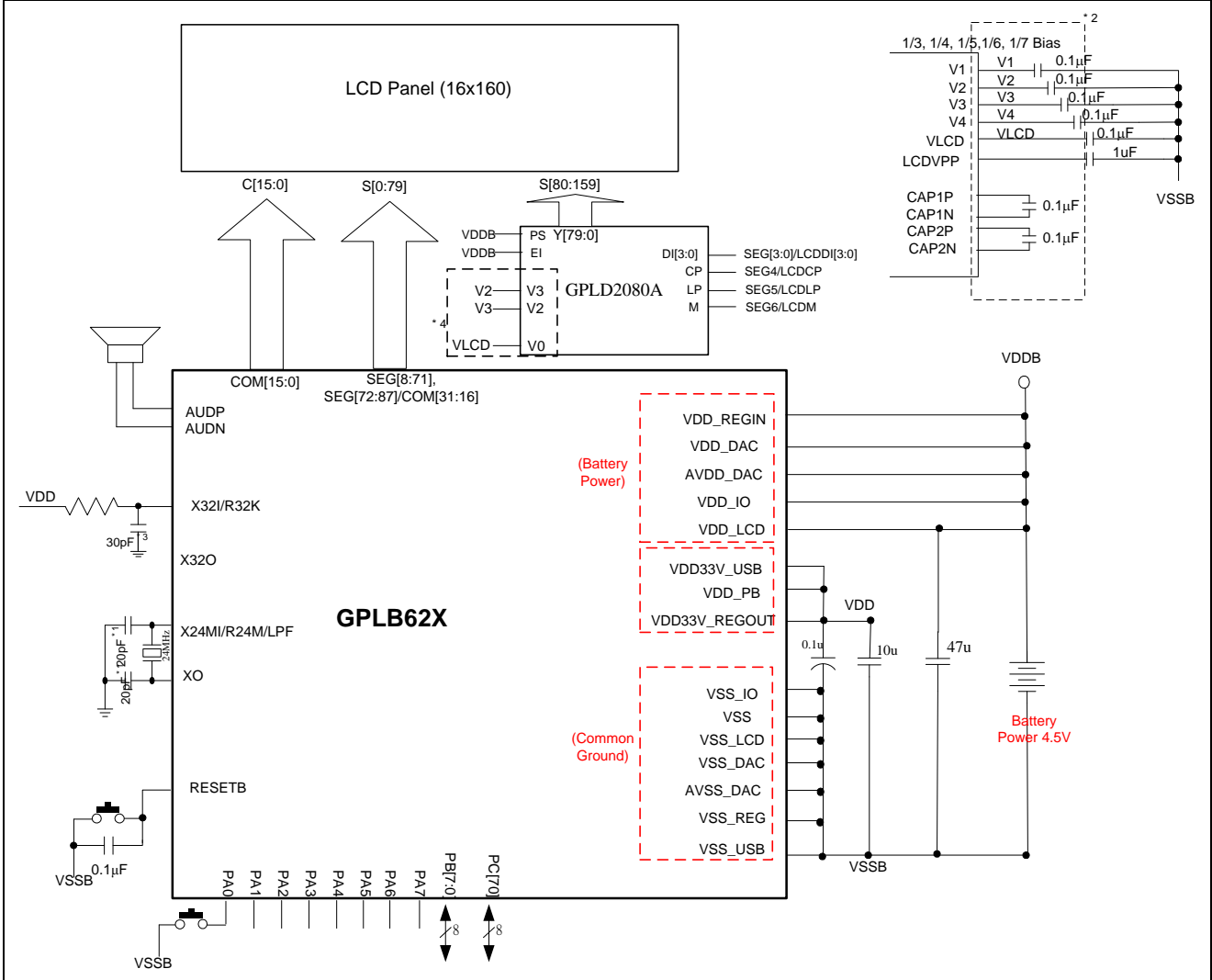

Note*1: These capacitor values are for design guidance only. Different capacitor values may be required for different crystal/resonator used.

Note*2: These capacitor values are for design guidance only. The ratio of LCDVPP capacitance to CAP1N/CAP1P/CAP2N/CAP2P capacitance is recommended to be 10:1. Generally, capacitance of VLCD and V1~V4 is 0.1μF and cannot be larger than capacitance of LCDVPP. But for larger LCD panel, the followings are recommended: 1μF capacitance for VLCD and V1~V4, 2.2μF capacitance for LCDVPP and 0.22μF capacitance for CAP1P/CAP1N/CAP2P/CAP2N.

Note*3: This capacitor can be removed if this node is immunized from noise.

Note*4: Please pay extra attention to the LCD power pin connection. GPLB62X's VLCD connects to GPLD2080A's V0. GPLB62X's V3 connects to GPLD2080A's V2. GPLB62X's V2 connects to GPLD2080A's V3.



10. PACKAGE/PAD LOCATIONS

10.1. Ordering Information

Product Number	Package Type
GPLB62200UA - NnnV - C	Chip form
GPLB62150UA - NnnV - C	Chip form
GPLB62100UA - NnnV - C	Chip form
GPLB62200A - NnnV - C	Chip form
GPLB62150A - NnnV - C	Chip form

Note1: Code number is assigned for customer.

Note2: Code number (N = A - Z or 0 - 9, nn = 00 - 99); version (V = A - Z).

11. DISCLAIMER

The information appearing in this publication is believed to be accurate.

Integrated circuits sold by Generalplus Technology are covered by the warranty and patent indemnification provisions stipulated in the terms of sale only. GENERALPLUS makes no warranty, express, statutory implied or by description regarding the information in this publication or regarding the freedom of the described chip(s) from patent infringement. FURTHERMORE, GENERALPLUS MAKES NO WARRANTY OF MERCHANTABILITY OR FITNESS FOR ANY PURPOSE. GENERALPLUS reserves the right to halt production or alter the specifications and prices at any time without notice. Accordingly, the reader is cautioned to verify that the data sheets and other information in this publication are current before placing orders. Products described herein are intended for use in normal commercial applications. Applications involving unusual environmental or reliability requirements, e.g. military equipment or medical life support equipment, are specifically not recommended without additional processing by GENERALPLUS for such applications. Please note that application circuits illustrated in this document are for reference purposes only.

12. REVISION HISTORY

Date	Revision #	Description	Page
JUL. 26, 2016	1.8	update IOH/IOL variation range.	10-11
AUG 04, 2014	1.7	update DC and regulator characteristic and its application circuit.	
JAN 22, 2014	1.6	DC characteristic update.	
JUL 30, 2013	1.5	Update VDD_IO/VSS_IO description, update application circuit for 32K xtal.	
JUN 29, 2012	1.4	Modify 9. APPLICATION CIRCUITS.	13~17
NOV. 21, 2011	1.3	1. Modify 4. FEATURES.	5
		2. Modify 7.5 LCD Controller/Driver.	8
		3. Modify 8.2 and 8.3 DC Characteristics.	10, 12
AUG. 12, 2011	1.2	1. Add halt current max value.	13
		2. Modify standby current max value.	13
		3. Modify chart.	14
APR. 07, 2011	1.1	1. Modify title name.	1,4
		2. Modify FEATURE in section 4.	5
		3. Modify naming in chart of section 7.11.	12,13
		4. Modify application in 9.3/9.4.	19,20
MAR. 15, 2011	1.0	1. Modify section 3. BLOCK DIAGRAM.	4
		2. Add 2 items in section 4. FEATURES/programmable LCD driver.	5
		3. Modify Map of memory and I/Os.	
		4. Modify section 8.2/8.3/8.7/8.8 for DC/AC contents.	13~15
		5. Add charts for section 8.4/8.5/8.6.	14
		6. Modify 9. APPLICATION CIRCUITS.	16~20
JUL. 20, 2010	0.1	Original	22