

**Micro-Power Boost DC/DC Converter****Features**

- Operating Voltage : 2.7V ~ 5.5V
- High Operating Frequency : 1MHz
- Shutdown Current : <math><1\mu\text{A}</math>
- High Output Voltage : Up to 30V
- Soft Start Function
- Cycle by Cycle Current Limiting
- SOT-23-5 Package

Applications

- STN/OLED BIAS
- Personal Digital Assistants
- DSC

General Description

The G5125 boost converter contains a 0.7Ω internal switch. The IC operates at constant frequency 1MHz, allowing the use of tiny, low cost and low height inductors and capacitors. The IC operates from a 2.7V to 5.5V supply voltage and can boost supply voltage up to 30V at the output. High inrush current at start-up is eliminated using the soft-start function. Constant frequency current mode PWM architecture results in low, predictable output noise. The G5125 includes cycle-by-cycle 850mA current limiting to maximum inductor current and over-temperature protection circuit. The G5125 is suitable for small or medium size LCD panel of high bias voltage with a constant current to provide PDAs, and other portable devices. The G5125 is available in SOT-23-5 package.

Ordering Information

ORDER NUMBER	MARKING	TEMP. RANGE	PACKAGE (Pb free)
G5125T11U	5125x	-40°C to 85°C	SOT-23-5

Note: T1: SOT-23-5

1 : Bonding Code

U: Tape & Reel

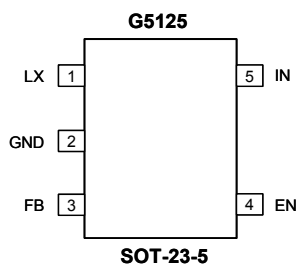
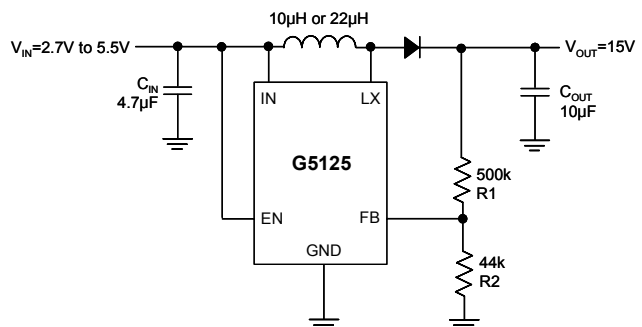
Pin Configuration**Typical Application Circuit**

Absolute Maximum Ratings

IN to GND.	-0.3V to 7V	Continuous Power Dissipation ($T_A=25^\circ\text{C}$)
LX to GND.	-0.3V to 35V	SOT-23-5
EN to GND.	-0.3V to VIN	Operating Temperature Range ¹
FB to GND.	-0.3V to VIN	Junction Temperature
Thermal Resistance Junction to Ambient, (θ_{JA})		Storage Temperature
SOT-23-5.	240°C/W	Reflow Temperature (soldering, 10sec)

Note:

1. It is guaranteed to meet performance specifications from 0°C to 85°C. Specifications over the -40°C to 85°C operating temperature range are assured by design, characterization and correlation with statistical process controls.

Electrical Characteristics

$V_{IN}=V_{EN}=3.6\text{V}$, $T_A = 25^\circ\text{C}$.

PARAMETER	CONDITIONS	MIN	TYP	MAX	UNITS
Operating Input Voltage		2.7	---	5.5	V
Quiescent Current	No Switching	---	0.2	0.3	mA
Shutdown Supply Current	EN=0V	---	0	1	μA
EN Input Level	V_{IH}	1.5	---	---	V
	V_{IL}	---	---	0.8	V
$UVLO_{RISING}$		2	2.25	2.5	V
Oscillator Frequency		---	1	---	MHz
Maximum Duty Cycle		85	90	---	%
Feedback Regulation Voltage		1.225	1.250	1.275	V
NMOS R_{DS-ON}	$I_{LX}=200\text{mA}$	---	700	---	mΩ
LX Leakage Current	EN=0, $V_{LX}=35\text{V}$	---	---	10	μA
Switching Current Limit	duty cycle=80%	700	850	1300	mA
Over Temperature	Trigger	---	120	---	°C
	Hysteresis	---	20	---	°C
Soft Start		---	0.5	---	ms

Pin Descriptions

PIN	Name	FUNCTION
1	LX	Power Switching Output
2	GND	Ground Pin.
3	FB	Feedback Input.
4	EN	Enable Input. Drive EN high to turn on the regulator, drive it low to turn it off.
5	IN	Power Input Pin. It must be bypassed with a low-ESR capacitor.

Block Diagram

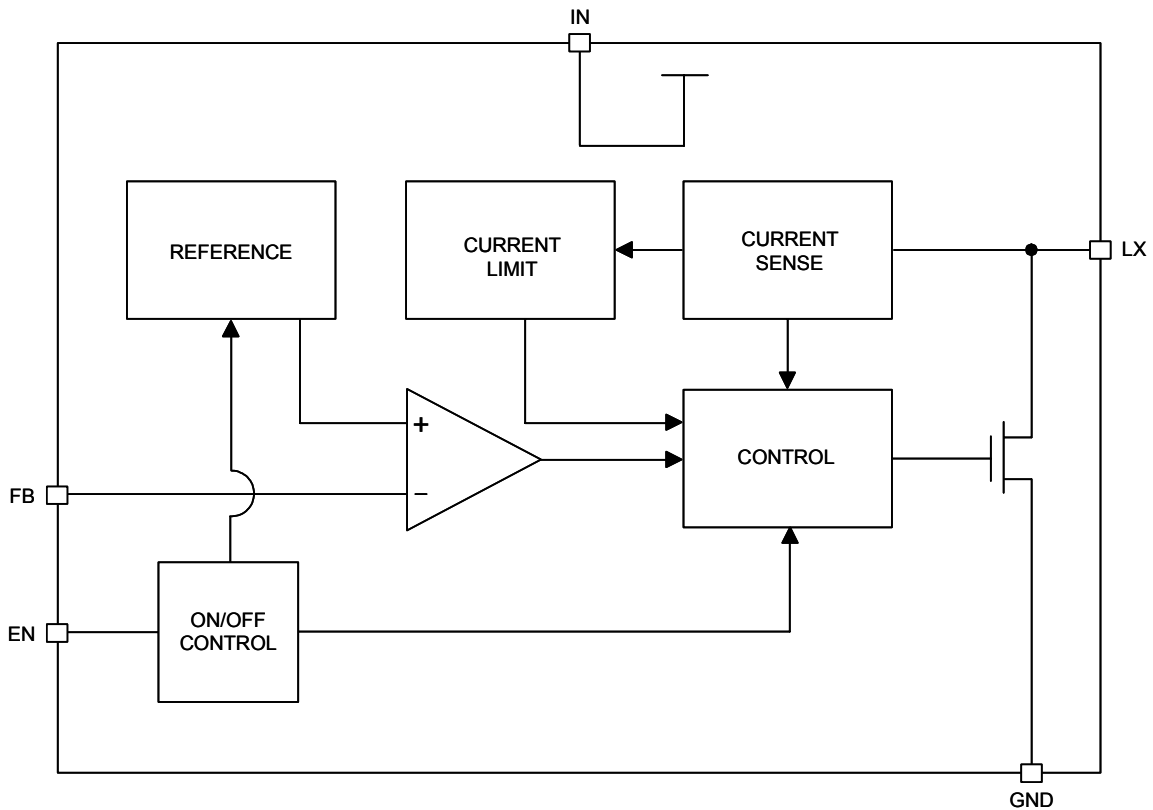



Operating

The G5125 step-up DC-DC converter operates from a 2.7V to 5.5V supply and converts up to 30V. The device includes an internal switching MOSFET with a 0.7Ω on-resistance and consumes 200 μ A of supply current. During startup, the G5125 limits the maximum on-time to limit initial battery inrush current. Adjust the output voltage by connecting a voltage divider from the output (VOUT) to FB. Select R1 and R2 (see application circuit) to set the voltage of FB (VFB) equaling 1.25V and VOUT may up to 30V. The G5125 built in a cycle-by-cycle 850mA current-limit function to maximum inductor current. The G5125 consumes 0.1 μ A when voltage of EN is Low.

Application Information

Inductor Selection

The inductor's saturation current rating should be greater than the peak switching current. The large inductance prevents the large inductor's current ripple to induce maximum current limit in on-time period and output voltage ripple can be reduced also. Inductor with low core losses and small DCR (cooper wire resistance) is recommended.

Capacitor Selection

The small size of ceramic capacitors makes them suitable for G5125 applications. X5R and X7R types are recommended because they retain their capacitance over wider voltage and temperature ranges than other types such as Y5V or Z5U. A minimum 10 μ F capacitor for output is required for most applications. Larger input/output capacitor minimizes input/output ripple.

Diode Selection

Schottky diodes, with their low forward voltage drop and fast reverse recovery, are the ideal choices for G5125 applications. The forward voltage drop of a Schottky diode represents the conduction losses in the diode, while the diode capacitance (C_T or C_D) represents the switching losses. For diode selection, both forward voltage drop and diode capacitance need to be considered. Schottky diodes with higher current ratings usually have lower forward voltage drop and large diode capacitance, which can cause significant switching losses at the 1MHz switching frequency of the G5125.

Package Information

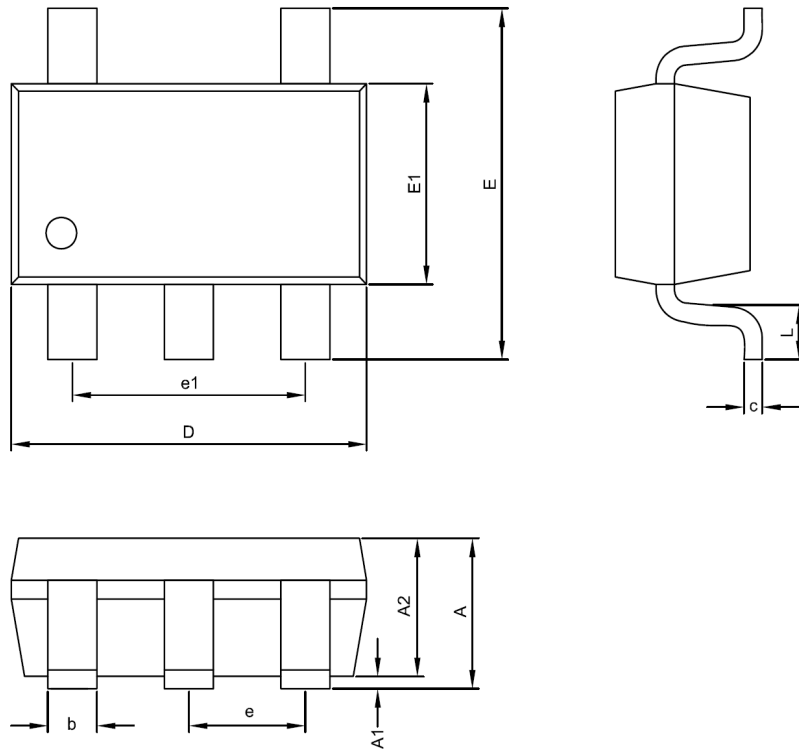

SOT-23-5 (T1) Package

Symble	DIMENSION IN MM			DIMENSION IN INCH		
	MIN.	NOM.	MAX.	MIN.	NOM.	MAX.
A	1.00	1.10	1.45	0.039	0.043	0.057
A1	0.00	---	0.15	0.000	---	0.006
A2	1.00	1.10	1.30	0.039	0.043	0.051
D	2.70	2.90	3.10	0.106	0.114	0.122
E	2.60	2.80	3.00	0.102	0.110	0.118
E1	1.50	1.60	1.70	0.059	0.063	0.067
c	0.08	0.15	0.25	0.003	0.006	0.010
b	0.30	0.40	0.50	0.012	0.016	0.020
e	0.95 BSC			0.037 BSC		
e1	1.90 BSC			0.075 BSC		
L	0.30	0.45	0.60	0.012	0.018	0.024

Taping Specification

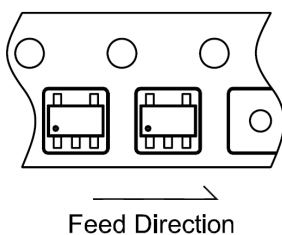

PACKAGE	Q'TY/REEL
SOT-23-5	3,000 ea

GMT Inc. does not assume any responsibility for use of any circuitry described, no circuit patent licenses are implied and GMT Inc. reserves the right at any time without notice to change said circuitry and specifications.