FR8003A Datasheet

Bluetooth Low Energy SOC with SIG Mesh integrated

Version:v0.4

Release Date:2021.12

FreqChip Conf1



Content

Tables	3
Figures	4
Description.....	5
Features	5
Applications.....	5
Ordering Information.....	5
1. Hardware Details.....	6
1.1 Block Diagram	6
1.2 Bluetooth Radio.....	7
1.3 Bluetooth Transmitter	7
1.4 Bluetooth Receiver	7
1.5 Bluetooth Controller	7
1.6 Audio Interface.....	8
2. Package and Pin Information.....	9
2.1 Package.....	9
2.2 Package Physical Dimensions	9
2.3 Pins Description	10
2.4 Application circuit	12
3. Electrical Characteristics.....	13
3.1 Absolute Maximum Ratings.....	13
3.2 Recommended Operating Conditions	13
3.3 Power Consumption.....	13
3.4 Crystal oscillator	14
Abbreviations	15
Contact Information	16
Revision History	16

Tables

Table 2-1 pin abbreviations.....	10
Table 2-2 pins description.....	11
Table 3-1 Absolute Maximum Ratings.....	13
Table 3-2 recommended operating conditions.....	13
Table 3-3 power consumption.....	13

FreqChip Confidential

Figures

Figure 1-1 Block Diagram	6
Figure 2-1 package	9
Figure 2-2 package physical dimensions	9
Figure 2-3 package physical dimensions	10
Figure 2-4 application circuit.....	12

FreqChip Confidential

Description

FR8003A is a SOC (system on chip) for rapid development of Bluetooth Low Energy related products. It contains Bluetooth V5.0 (LE Mode) fully compliant system with Freqchip designed firmware and software stack. Users can develop various applications based on embedded 32-bits high performance MCU.

With Freqchip's innovational technology, FR8003A integrates, PMU, QSPI flash ROM with XIP mode, I2C, UART, GPIO, ADC, USB OTG, PWM all in a single chip, which provides customer with:

1. competitive power consumption
2. stable connection
3. low-cost BOM

The Bluetooth Smart firmware includes the L2CAP service layer protocols, Security Manager (SM), Attribute Protocol (ATT), the Generic Attribute Profile (GATT) and the Generic Access Profile (GAP). Furthermore, application profiles such as Proximity, Health Thermometer, Heart Rate, Blood Pressure, Glucose, Human Interface Device (HID) and SDK (include drivers, OS API, etc.) are supported. The SDK has integrated SIG Mesh for networking application.

Features

- Compliant with Bluetooth Specification V5.0 LE, support 2M, 1M, 500K and 125K data rate
- Embedded 32-bits Processor
 - up to 96Mhz speed
- Internal mask 128KB ROM, up to 64KB SRAM
- Internal 512KB Flash ROM for user space software and data
- Integrated Battery Charger
- Integrated DC-DC Regulator

- Interface:
 - GPIO
 - UART
 - SPI/QSPI
 - I2C
 - PWM
 - USB OTG
- ROM Software:
 - BLE Profile & Protocol: GATT, LM, LC, etc.
 - Driver API
 - SIG Mesh

Applications

- Smart Mouse
- Bluetooth Wearable
- SIG Mesh Application
- Smart Locks
- Domestic Appliances

Ordering Information

FR8003A -20°C ~ +85°C

- QFN20, 3.0*3.0*0.75, 0.4pitch

1. Hardware Details

1.1 Block Diagram

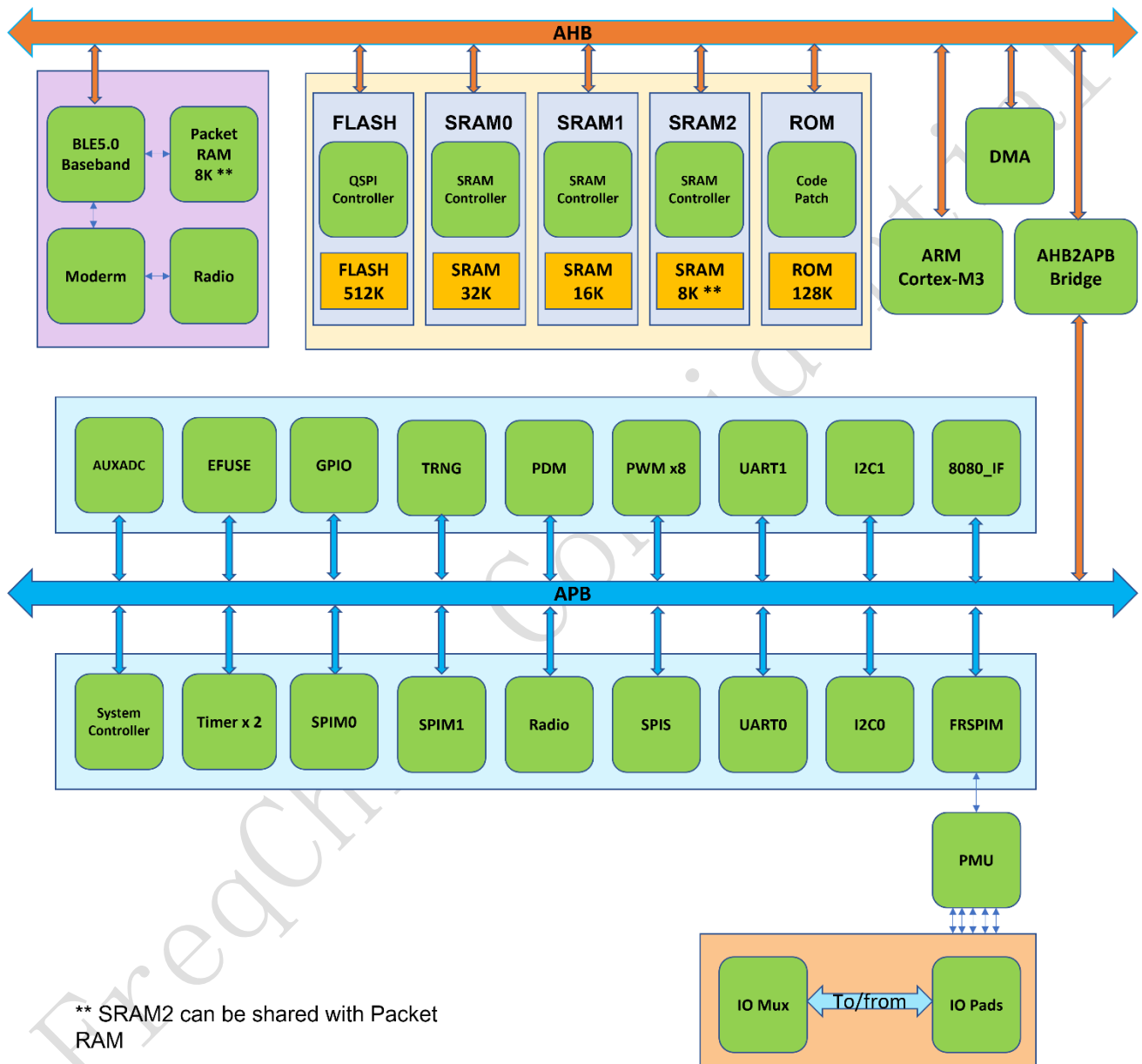

Figure 1-1 Block Diagram

1.2 Bluetooth Radio

- On-chip balun (50Ω impedance in TX and RX modes)
- No external trimming is required in production
- Qualified to Bluetooth v5.0 LE specification
- Up to 10dBm RF transmit power
- -98dBm (1M) receiver sensitivity in LDO mode
- Integrated channel filters
- Digital demodulator for improved sensitivity and co-channel rejection
- Real time digitized RSSI

1.3 Bluetooth Transmitter

- All device classes support (Broadcaster, Central, Observer, Peripheral)
- All packet types (Advertising / Data / Control)
- Encryption (AES / CCM)
- Bit stream processing (CRC, Whitening)
- Frequency hopping calculation
- Low power modes supporting internal 32.0 kHz RC oscillator
- Supports power down of the baseband during the protocol's idle periods

1.4 Bluetooth Receiver

- UART port for Debugging and AT Commands
- IIC interface to support external EEPROM or other devices (like G-SENSOR)
- Up to 11 general purpose IOs (11 IOs can be set in interrupt mode)
- General purpose 10-bits ADC used for ADKey and other analog input
- 8-channel PWM controller, with dead time control
- General purpose programmable timer for various task
- Watchdog used for tracking unexpected exception

1.5 Bluetooth Controller

- Embedded Power-On-Reset
- On-chip high efficiency switch-mode power supply, 1.8v to 4.3v input direct from battery and programmable output voltage
- On-chip Low Dropout (LDO) Linear Regulator for internal Digital, RF and Analog circuit
- Power management features include software shutdown and hardware wake-up
- Power-on-reset cell detects low supply voltage
- Internal voltage level detector

1.6 Audio Interface

- Lithium ion/Lithium polymer battery charger
- Embedded LVD(low voltage detect)
- Programmable charging current. Fast charging support up to 200mA with no external components

FreqChip Confidential

2. Package and Pin Information

2.1 Package

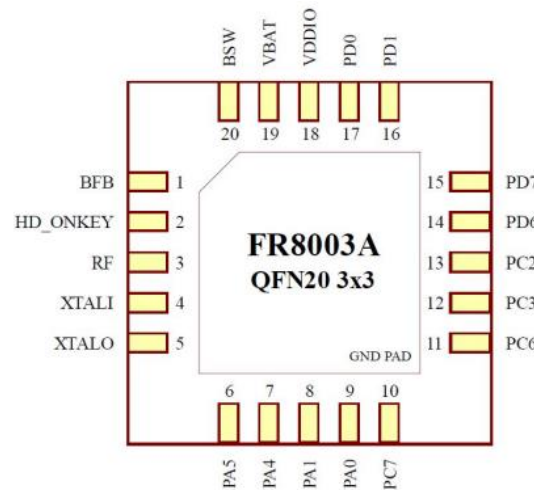

Figure 2-1 package

2.2 Package Physical Dimensions

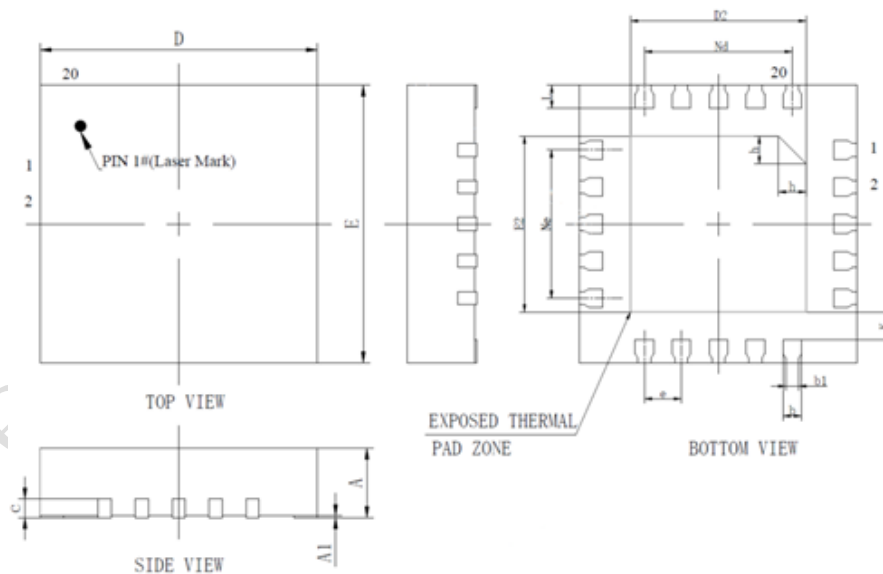

Figure 2-2 package physical dimensions

SYMBOL	MILLIMETER		
	MIN	NOM	MAX
A	0.70	0.75	0.80
A1	0	0.02	0.05
b	0.15	0.20	0.25
b1	0.14REF		
c	0.203REF		
D	2.90	3.00	3.10
D2	1.80	1.90	2.00
e	0.40BSC		
Ne	1.60BSC		
Nd	1.60BSC		
E	2.90	3.00	3.10
E2	1.80	1.90	2.00
L	0.20	0.25	0.30
h	0.25	0.30	0.35
K	0.30REF		

Figure 2-3 package physical dimensions

2.3 Pins Description

FR8003A is a CMOS device. Floating level on input signals will cause unstable device operation and abnormal current consumption. Pull-up or Pull-down resistors should be used appropriately for input or bidirectional pins.

Table 2-1 pin abbreviations

Notation	Description
AI	Analog input
AO	Analog output
IO	Bidirectional(digital)
PWR	Power
GND	Ground

Table 2-2 pins description

Pin No.	Pin Name	Type	Description
1	BFB	AI	BUCK feedback input
2	HD_ONKEY	AI	Wake up input pin (while in power off mode)
3	RF	AI/O	RF input and output
4	XTALI	AI	24MHz Crystal oscillator input
5	XTALO	AO	24MHz Crystal oscillator output
6	PA5	IO	Multi-function input/output digital IO
7	PA4	IO	Multi-function input/output digital IO
8	PA1	IO	Multi-function input/output digital IO
9	PA0	IO	Multi-function input/output digital IO
10	PC7	IO	Multi-function input/output digital IO
11	PC6	IO	Multi-function input/output digital IO
12	PC3	IO	Multi-function input/output digital IO
13	PC2	IO	Multi-function input/output digital IO
14	PD6	IO	Multi-function input/output digital IO
15	PD7	IO	Multi-function input/output digital IO
16	PD1	IO	Multi-function input/output digital IO
17	PD0	AI	Multi-function input/output digital IO
18	VDDIO	AO	Analog linear regulator output
19	VBAT	PWR	Battery positive supply input or charger output
20	BSW	AO	BUCK Switch output

2.4 Application circuit

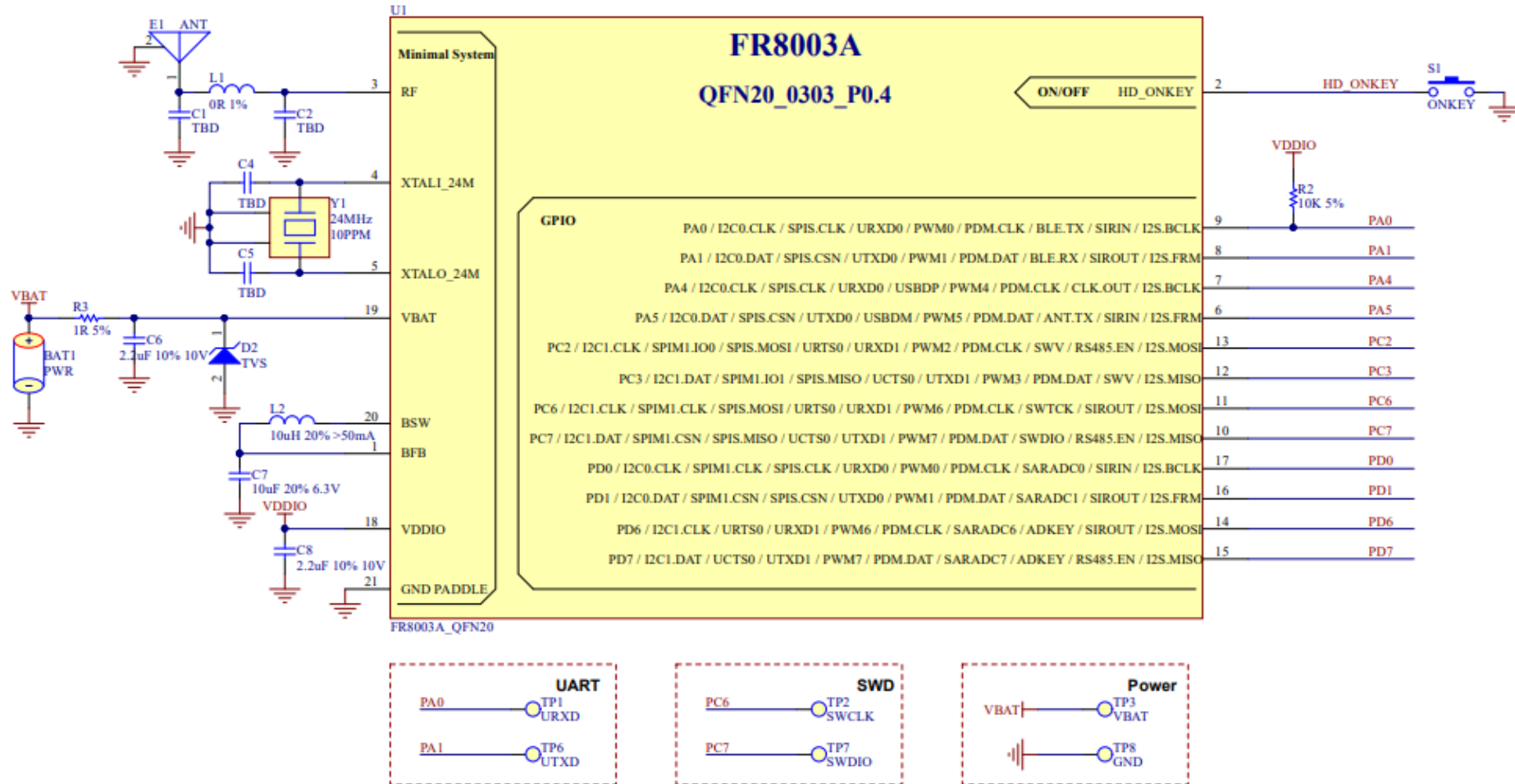

Figure 2-4 application circuit

3. Electrical Characteristics

3.1 Absolute Maximum Ratings

Continuous operation at or beyond these conditions may permanently damage the device.

Table 3-1 Absolute Maximum Ratings

Rating		Min	Max	Unit
Storage Temperature		-40	125	°C
Core Supply Voltage		0.9	1.2	V
I/O Voltage	VDDIO	1.6	3.3	V
Supply Voltage	VBAT	1.8	4.3	V
	VCHG	4.75	5.25	V

3.2 Recommended Operating Conditions

Table 3-2 recommended operating conditions

Operating Condition		Min	Typ	Max	Unit
Operating Temperature Range		-20	25	85	°C
Core Supply Voltage		0.9	1.1	1.2	V
I/O Voltage	VDDIO	1.6	1.8	3.3	V
Supply Voltage	VBAT	1.8	3.3	4.3	V
Charge input voltage	VCHG	4.75	5	5.25	V

VDDIO : Power-on default value is 1.8, user configurable later

3.3 Power Consumption

Table 3-3 power consumption

Operation Mode	Average	Max	Unit
TX peek current (0dB)		6.2	mA
RX peek current		6.5	mA
Deep sleep current (include 64K retention RAM)	<5		μA
Power off	<1		μA

3.4 Crystal oscillator

Clock Source	Min	Typ	Max	Unit
Main Crystal OSC(24MHz) for Bluetooth RF application				
Clock Frequency	24	24	24	MHz
Tolerance		+/-10		ppm

Abbreviations

Abbreviations	Descriptions
AEC	acoustic echo cancellers
AGC	Automatic Gain Control
ANS	Automatic Noise Suppression
ADC	Analog-to-Digital-Converter
DAC	Digital-to-Analog-Converter
GPIO	General Purpose Input Output
MIC	Microphone
PMU	Power Management Unit
OSC	Oscillator
PA	Power Amplifier
SoC	system on chip

Contact Information

Website: www.freqchip.com

Sales Email: sales@freqchip.com

Phone: +86-21-5027-0080

Revision History

Feedback:

Freqchip welcomes feedback on this product and this document. If you have comments or suggestions, please send an email to docs@freqchip.com.

Reversion Number	Reversion Date	Description
V0.1	2021.7.12	Initial Draft
V0.2	2021.7.29	Update pins description
V0.3	2021.11.18	Update pins description delete RESET add PD6
V0.4	2021.12.2	Update pins description delete VCHG add HD_ONKEY