

USB Dedicated Charging Port Controller for Fast Charging Protocol and QC 2.0/3.0

Description

The FP6600Q is a fast charge protocol controller for HiSilicon Fast Charging Protocol (FCP) and Qualcomm® Quick Charge™ 2.0/3.0(QC 2.0/3.0) USB interface. The device can fast charging FCP or QC 2.0/3.0 powered device (PD). The protocol feature monitors USB D+/D- data line voltage or D- data line transmission and automatically adjusts output voltage of power bank and wall adaptor to optimize charge time.

FP6600Q can support not only USB BC compliant devices, but also Apple / Samsung / HUAWEI devices and automatically detects whether a connected powered device is QC 2.0/3.0 or FCP capable before enabling output voltage adjustment. If a PD not compliant to QC 2.0/3.0 or FCP is detected the FP6600Q disables output voltage adjustment to ensure safe operation with legacy 5 V only USB PDs.

The FP6600Q is available in SOP-8 package.

Features

- Support HiSilicon Fast Charging Protocol (FCP) for Output Voltage and Current Communication
- Support Qualcomm® Quick Charge™ 2.0/3.0
 - Class A : 3.6V up to 12V Output Voltage
 - Class B : 3.6V up to 20V Output Voltage
- Automatic Selection FCP and QC 2.0/3.0 Protocols
- Supports USB DCP Shorting D+ Line to D- Line per USB Battery Charging Specification, Revision 1.2
- Meets Chinese Telecommunication Industrial Standard YD/T 1591-2009
- Supports USB DCP Applying 2.7V on D+ Line and 2.7V on D- Line
- Supports USB DCP Applying 1.2V on D+ and D- Lines
- Output Over Voltage Protection
- Over Temperature Protection
- Distant Shutdown Protection
- SOP-8 Pb-Free Package
- UL Certification No. 4787452991-2

Applications

- Wall-Adapter, Smart Phones, Tablets, Notebooks
- Mobile / Tablet Power Bank
- Car Charger
- USB Power Output Ports

Pin Assignments

SO Package(SOP-8)

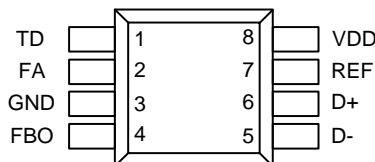
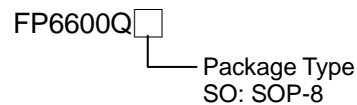

Figure 1. Pin Assignment of FP6600Q

Ordering Information



Typical Application Circuit

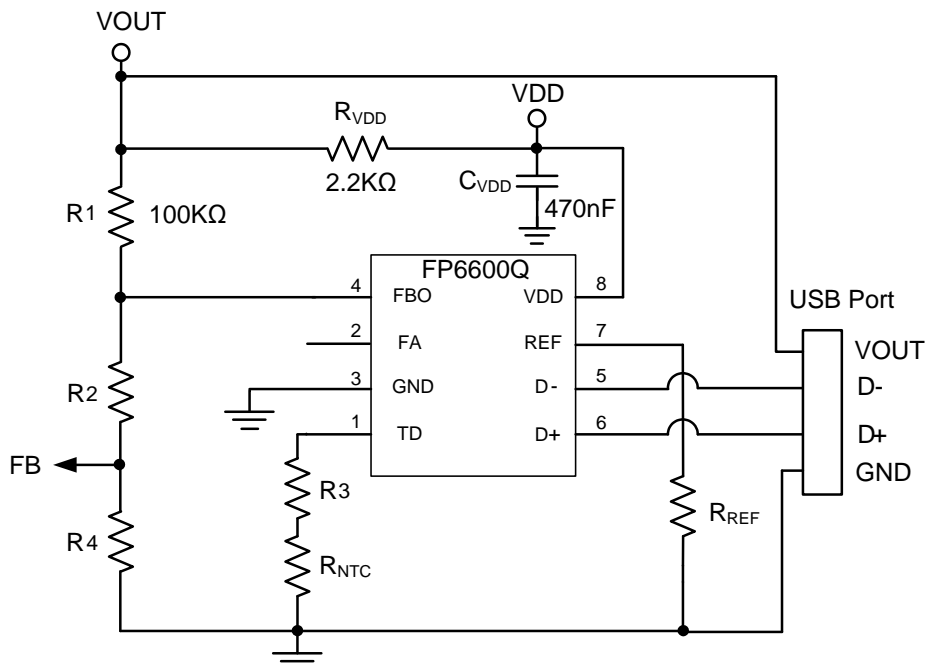

Figure 2. Typical Application Schematic

Output Voltage Lookup Table(QC 2.0/3.0)

D+	D-	Output Voltage
3.3V	3.3V	20V
0.6V	0.6V	12V
3.3V	0.6V	9V
0.6V	3.3V	Continuous mode
0.6V	High-Z	5V (Default)

Functional Pin Description

Pin Name	Pin No. (SOP-8)	Pin Function
TD	1	Connect external temperature sensor (NTC resistor).
FA	2	If any fault (OVP, OTP, DSP) occur then FA pin source current.
GND	3	Ground pin.
FBO	4	Feedback output. Current Sink/Source FB Node.
D-	5	USB D- data line input pin.
D+	6	USB D+ data line input. Recommended this pin connect without resistors(open) or with a resistor higher than 1MΩ connect to GND.
REF	7	Through connect resistor provides output voltage selection. ($R_{REF} > 33k$ or REF pin logic high select Class A and $R_{REF} < 15k$ or REF pin logic low select Class B.)
VDD	8	Power supply input pin.

Block Diagram

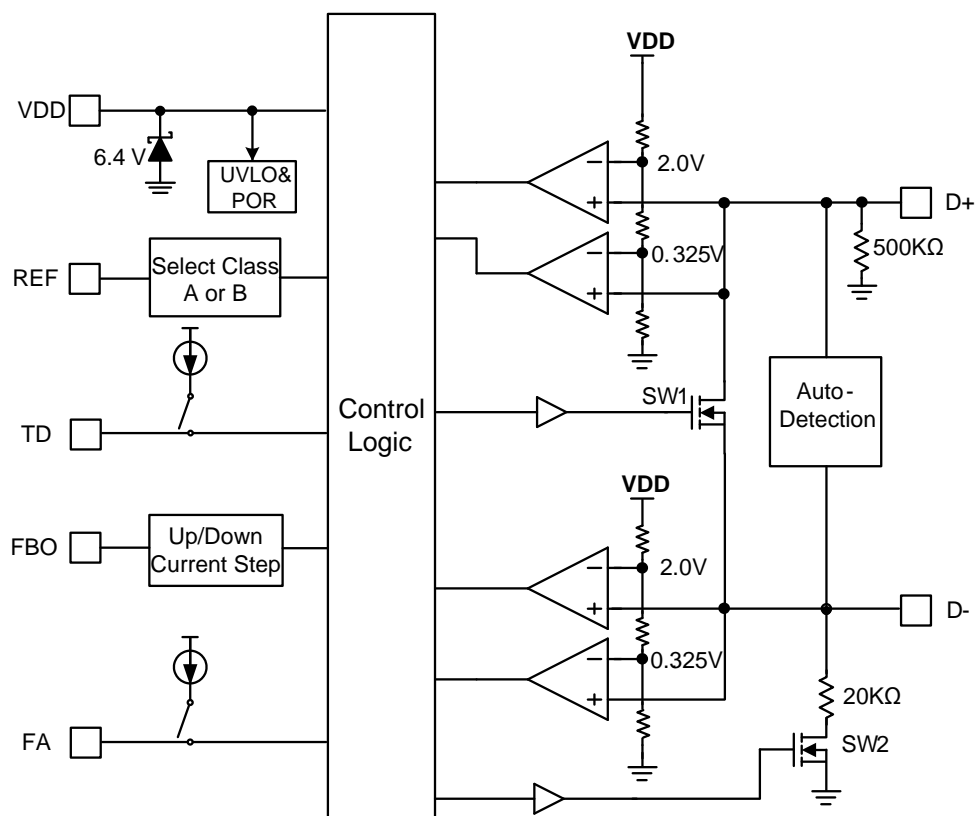

Figure 3. Block Diagram of FP6600Q

Absolute Maximum Ratings ^(Note 1)

- Input Supply Voltage VDD ----- -0.3V to +6.5V
- All Other Pins Voltage ----- -0.3V to +6.5V
- Maximum Junction Temperature (T_J)----- +150°C
- Storage Temperature (T_S)----- -65°C to +150°C
- Lead Temperature (Soldering, 10sec.) ----- +260°C
- Power Dissipation @ T_A=25°C, (P_D)
 - SOP-8 ----- 1.39W
- Package Thermal Resistance, (θ_{JA}) ^(Note 2)
 - SOP-8----- 90°C/W
- Package Thermal Resistance, (θ_{JC})
 - SOP-8----- 39°C/W

Note 1 : Stresses beyond this listed under "Absolute Maximum Ratings" may cause permanent damage to the device.

Note 2 : θ_{JA} is measured at 25°C ambient with the component mounted on a high effective thermal conductivity test board of JEDEC-51-7.

Recommended Operating Conditions

- Input Supply Voltage (VDD)----- 3.2V to 6.4V
- Operation Temperature Range (T_{OPR}) ----- -40°C to +85°C

Note 3 : Over operating free-air temperature range (unless otherwise noted)

Electrical Characteristics

(VDD=5V, TA=25°C and the recommended supply voltage range, unless otherwise specified.)

Parameter	Symbol	Conditions	Min	Typ	Max	Unit	
Input Power							
VDD Input Voltage Range	V _{DD}		3.2		6.4	V	
Input UVLO Threshold	V _{UVLO(VTH)}	V _{DD} Falling	2.5		2.9	V	
VDD Supply Current		V _{DD} =5V, Measure V _{DD}		200		μA	
VDD Shunt Voltage	V _{DD(SHUNT)}	I _{VDD} = 3mA	5.9	6.4	6.8	V	
High Voltage Dedicated Charging Port (HVDCP)							
Data Detect Voltage	V _{DAT(REF)}		0.25	0.325	0.4	V	
Output Voltage Selection Reference	V _{SEL_REF}		1.8	2.0	2.2	V	
D+ High Glitch Filter Time	T _{GLITCH(BC)-D+_H}		1000	1250	1500	ms	
D- Low Glitch Filter Time	T _{GLITCH(BC)-D-_L}			1		ms	
Output Voltage Glitch Filter Time	T _{GLITCH(V)CHANGE}		20	40	60	ms	
D- Pull-Down Resistance	R _{D-(DWN)}			20		kΩ	
Continuous Mode Glitch Filter Time ^(Note 4)	T _{GLITCH-CON T-CHANGE}		100		200	μs	
D+ Leakage Resistance	R _{DAT-LKG}	V _{DD} =3.2-6.4V, VD+=0.6-3.6V Switch SW1=Off	300	500	800	kΩ	
Switch SW1 On-Resistance	R _{DS_ON,N1}	V _{DD} =5V, SW1= 200μA			40	Ω	
Up/Down Current Step		I _{UP} = 40μA (9V), 70μA (12V)		2		μA	
DCP 1.2V Charging Mode							
D+ _{-1.2V} /D- _{-1.2V} Line Output Voltage			1.08	1.2	1.32	V	
D+ _{-1.2V} /D- _{-1.2V} Line Output Impedance				100		kΩ	
Apple 2.4A Mode							
D+ _{-2.7V} /D- _{-2.7V} Line Output Voltage			2.57	2.7	2.84	V	
D+ _{-2.7V} /D- _{-2.7V} Line Output Impedance				33.6		kΩ	
Protection							
Over Voltage Protection Threshold Voltage	V _{OV}	QC 2.0 Mode	I _{UP} =0A (5V)	1.42	1.52	1.62	V
			I _{UP} =40μA (9V)	1.58	1.72	1.86	
			I _{UP} =70μA (12V)	1.72	1.87	2.02	
			I _{UP} =150μA(20V)	2.1	2.28	2.46	

Electrical Characteristics

(VDD=5V, T_A=25°C and the recommended supply voltage range, unless otherwise specified.)

Parameter	Symbol	Conditions	Min	Typ	Max	Unit	
Over Voltage Protection Threshold Voltage	V _{OV}	QC 3.0 Continuous Mode	R _{REF} > 33 kΩ or Logic High, Class A	1.72	1.87	2.02	V
		R _{REF} < 15 kΩ or Logic Low, Class B	2.1	2.28	2.46		
Over Voltage Detection Deglitch Time ^(Note 4)				60		μs	
Over Voltage Detection Blanking Time			500			ms	
Over Temperature Threshold	V _{OT}		1.1	1.2	1.3	V	
Over Temperature Deglitch Time				1		ms	
Temperature Monitor Current Source			80		120	μA	
Temperature Monitor On Time			10		13	ms	
Protection Current Source			90	130	170	μA	
D- SECTION (FCP)							
D- FCP Tx Valid Output High	V _{TX-VOH}		2.55		3.6	V	
D- FCP Tx Valid Output Low	V _{TX-VOL}				0.3	V	
D- FCP Rx Valid Output High	V _{RX-VIH}		1.4		3.6	V	
D- FCP Rx Valid Output Low	V _{RX-VIL}				1.0	V	
D- Output Pull-Low Resistance (FCP) ^(Note 4)	R _{PD}		400	500	600	Ω	
Unit Interval For FCP PHY Communication	UI	f _{CLK} = 125kHz	144	160	180	μs	

Note 4 : Not production tested.

Application Information

Function Description

The FP6600Q is a USB high voltage dedicated charging port interface IC for Qualcomm[®] Quick Charge[™] 2.0/3.0, HiSilicon FCP specification.

The FP6600Q is a USB Dedicated Charging Port Controller can fast charge most of the handheld devices. It can be like the original charging adapter. The FP6600C can support BC1.2, Apple, Samsung and HUAWEI.

It also supports full output voltage range of QC 2.0/3.0 Class A or Class B.

Quick Charge 2.0/3.0 Interface

Power up D+/D- is supply 2.7V to Apple Device and then supply D+ short to D- into BC1.2. Set the output voltage level 5V. If D+ continuous above 0.325V and keep 1.25 seconds FP6600Q can automatic choose into QC 2.0/3.0 or FCP operation mode.

When $V_{DAT(REF)} < D+ < V_{SEL_REF}$ and $D- > V_{SEL_REF}$, the FP6600Q enter continuous mode. Each step D+ from 1V to 3V Pulse-width during 200us cause current sink 2uA by FBO. The maximum output sink current is 70uA for output voltage reach to 12V.

Each step D- from 3V to 1V Pulse-width during 200us cause current source 2uA by FBO. The minimum output source current is 14uA for output voltage reach to 3.6V.

If PD without QC 2.0 the device will keep output voltage level 5V guarantee safe operation for only 5V USB PD. When USB cable unplug the D+ voltage $< V_{DAT(REF)}$ and output voltage recovery default mode 5V.

Shunt Regulator

The wide power supply output voltage through external resistor from R_{VDD} to VDD. The internal with Zener-Diode clamp VDD pin at 6.4V. Recommend $R_{VDD} = 2.2K\Omega$ and $C_{VDD} = 470nF$.

Output Voltage Select

Support output range Class A (3.6V to 12V) for $R_{REF} > 33k$ or REF pin connect to VDD. Otherwise, Class B (3.6V to 20V) for $R_{REF} < 15k$ or REF pin connect to GND.

Output Overvoltage Protection

When $FBO > V_{OV}$ represent the output voltage exceed 1.2 times for setting output voltage level lead to the FA pin protection current source. When output voltage step down (an example 12V to 5V) and the OVP Blanking for 500ms.

Over Temperature Protection

When over temperature occur by TD pin voltage level below V_{OT} lead to FA pin protection current source.

Distant Shutdown Protection

FP6600Q permit the powered device (PD) can shut down the power by DSP. When Distant shutdown occur lead to FA pin protection current source.

Outline Information

SOP-8 Package (Unit: mm)

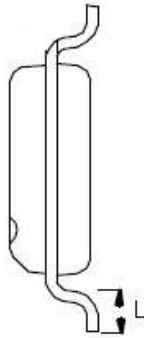
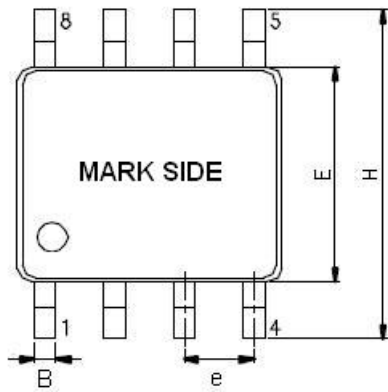

SYMBOLS UNIT	DIMENSION IN MILLIMETER	
	MIN	MAX
A	1.35	1.75
A1	0.10	0.25
A2	1.25	1.50
B	0.31	0.51
D	4.80	5.00
E	3.80	4.00
e	1.20	1.34
H	5.80	6.20
L	0.40	1.27

Note : Followed from JEDEC MO-012-E

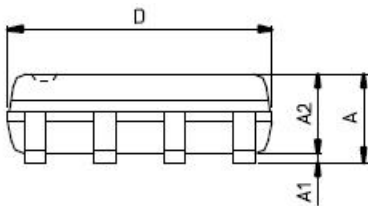

Carrier dimensions

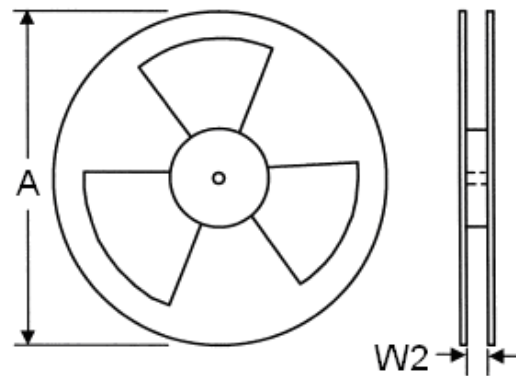
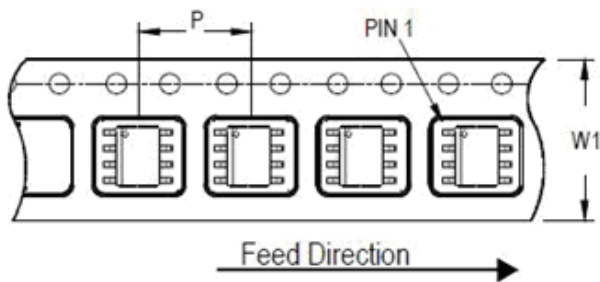

Tape Size (W1) mm	Pocket Pitch (P) mm	Reel Size (A)		Reel Width (W2) mm	Empty Cavity Length mm	Units per Reel
		in	mm			
12	8	13	330	12.4	400~1000	2,500

Life Support Policy

Fitipower's products are not authorized for use as critical components in life support devices or other medical systems.