

# PRODUCT SPECIFICATION

DATE: 03/26/00'

<b>COSMO</b> ELECTRONICS CORPORATION	REED RELAY: <b>D1C050000</b>	NO. 50R01019	REV.
		SHEET 1 OF 2	2

## 1. OUTSIDE DIMENSION : UNIT ( mm )

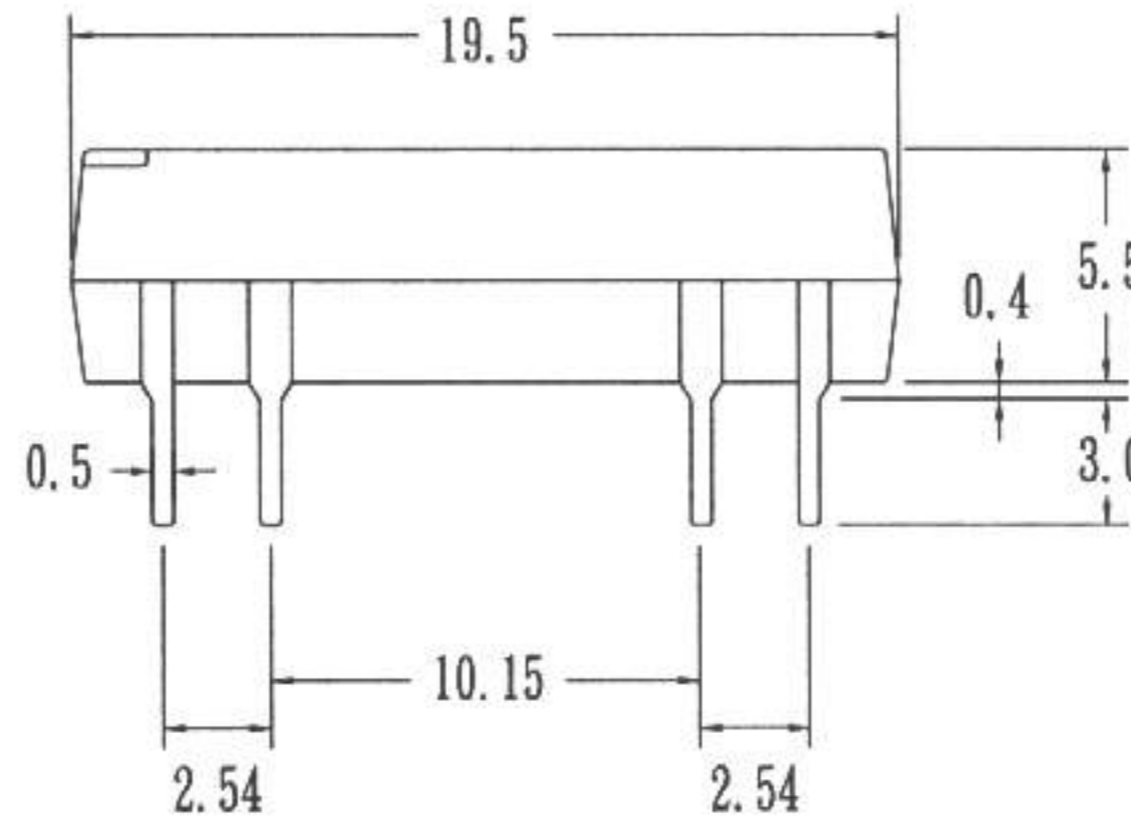
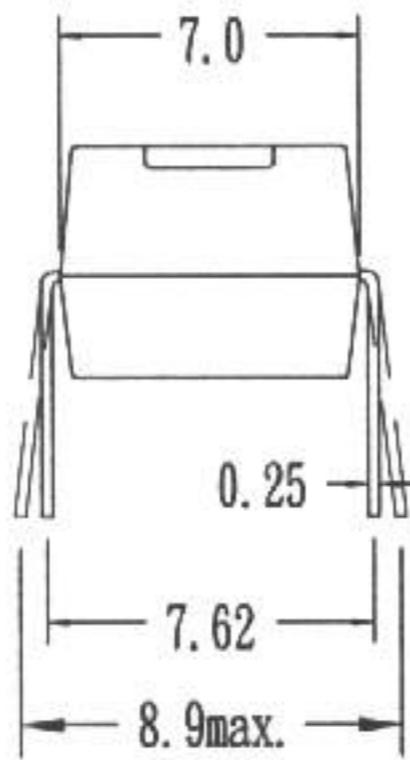

TOLERANCE :  $\pm 0.1\text{mm}$

## 2. SCHEMATIC : TOP VIEW

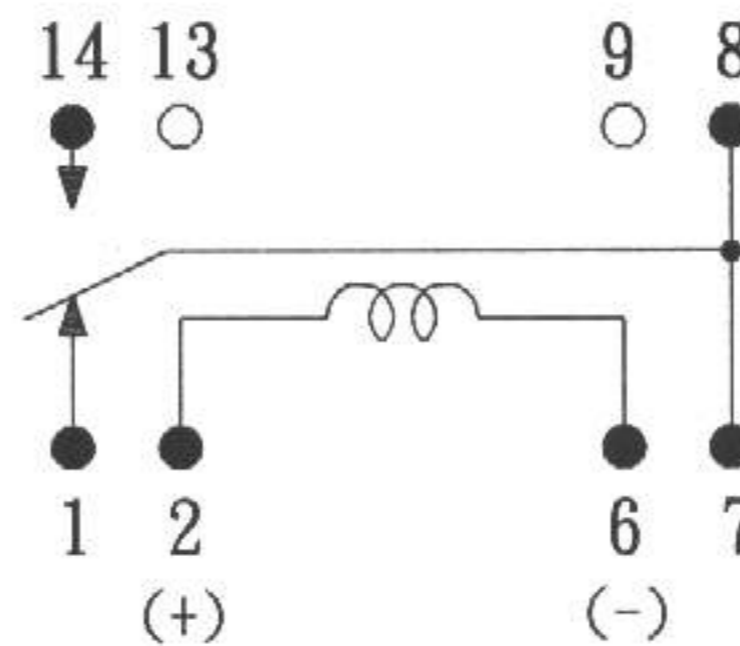

ISSUE

Dean. Yu.  
03-28-00

CHECK

Alan Sai 03-29-00

APPROVED

Stan Hsu 4-1-00

# PRODUCT SPECIFICATION

DATE: 03/26/00'

<b>COSMO</b>	REED RELAY: <b>D1C050000</b>	NO. 50R01019	REV.
ELECTRONICS CORPORATION		SHEET 2 OF 2	2

3.0 COIL RATINGS: (AT 20°C)

3.1 Coil resistance	200	Ω	(±10%)
3.2 Nominal coil current	5	VDC	
3.3 Maximun Continuous voltage	10	VDC	
3.4 Must operate	3.75	VDC	
3.5 Must release	1.0	VDC	
3.6 Rated current	25	mA	

4.0 ELECTRONICAL CHARACTERISTICS:

4.1 Contact resistance	150	mΩ	(max)
4.2 Operate time	1.0	ms	(max)
4.3 Bounce time	2.0	ms	(max)
4.4 Release time	1.0	ms	(max)
4.5 Insulation resistance (100 VDC open contact)	10 <sup>9</sup>	Ω	(min)
4.6 Power	3	VA	(max)
4.7 Switching voltage	100	VDC	(max)
4.8 Switching current	0.25	A	(max)
4.9 Carry current	0.5	A	(max)
4.10 Breakdown voltage (across open contact)	200	VDC	(min)
(between coil & contact)	500	VDC	(min)
4.11 Life expectancy (signal level)	5*10 <sup>7</sup>		
4.12 Operating temp	-40 to 85°C		
4.13 Storage temp	-50 to 125°C		
4.14 Resonant frequency	3.5	KHZ	
4.15 Vibration (10-2000HZ)	20	g	(max)
4.16 Minimum permissible load	100	mVDC	10uA

ISSUE <i>Dean. Yu. 03-28-00</i>	CHECK <i>Alan Loi 03-29-00</i>	APPROVED <i>Sten Hau 4-1-00</i>
------------------------------------	-----------------------------------	------------------------------------