

Features

- 5.8 GHz Transceiver
- 5 dBm TX Output Power
- -97 dBm Sensitivity
- 1152 kBit/s Data-rate
- Supply-voltage Range 2.9V to 3.6V
- Low IF Receiver
- Low Current Consumption
- Few Low Cost External Components
- No Mechanical Adjustment Required
- Small 32 pin 5 mm × 5 mm QFN Package

Applications

- 5.8 GHz Digital Cordless Phones
- Game Controllers
- Wireless Head Set
- FCC Part 15 Compliant Radio Link

1. Description

The ATR2820 is a single chip RF-transceiver for applications in the 5.8 GHz ISM band. The QFN32 packaged IC is a complete transceiver including image rejection mixer, low IF filter, FM demodulator, RSSI, TX preamplifier, integrated PLL with fully integrated VCO. No mechanical adjustment is necessary in production.

www.DataSheet4U.com



Low IF WDCT 5.8 GHz Transceiver

ATR2820

Preliminary

4704D-DECT-11/06



www.DataSheet4U.com

Figure 1-1. Block Diagram

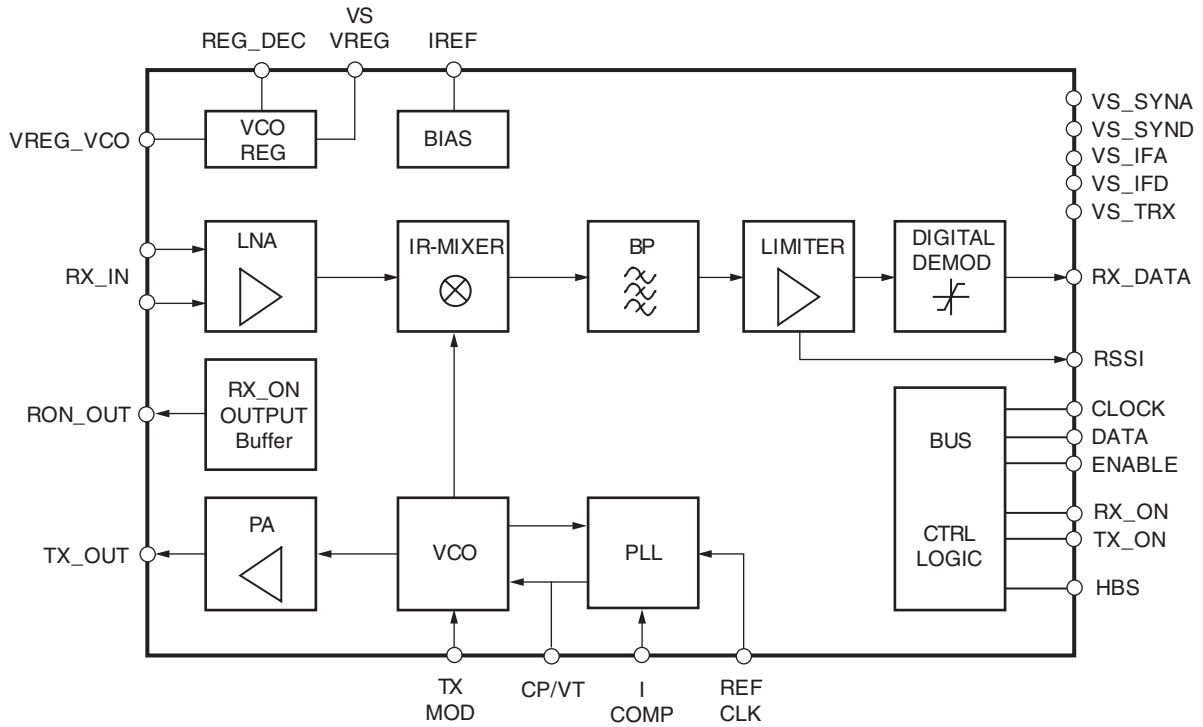

www.DataSheet4U.com

2. Pin Configuration

Figure 2-1. Pinning QFN32 – 5 mm × 5 mm

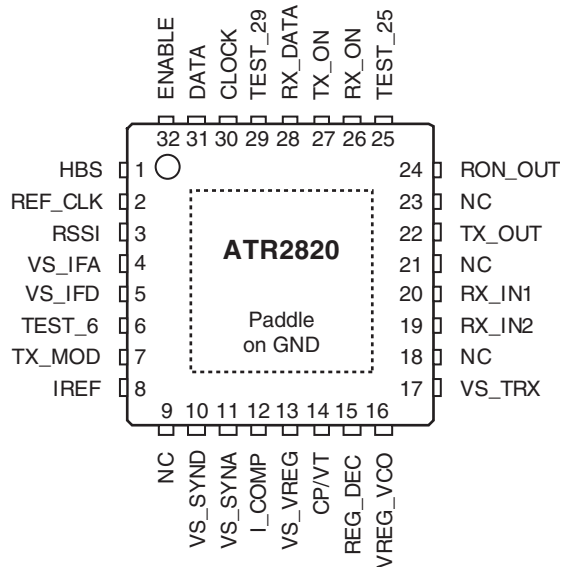

Table 2-1. Pin Description

Pin	Symbol	Function
Paddle	GND	Ground
1	HBS	Handset/Basemode select: High = Basemode; Low = Handsetmode
2	REF_CLK	Reference frequency input
3	RSSI	Received signal strength indicator output
4	VS_IFA	Supply voltage for analog part of the IF circuit
5	VS_IFD	Supply voltage for digital part of the IF circuit
6	TEST_6	Test pin
7	TX_MOD	Input for analog TX data signal
8	IREF	External resistor for bias circuit
9	NC	Not connected
10	VS_SYND	Supply voltage for digital part of the PLL
11	VS_SYNA	Supply voltage for analog part of the PLL
12	I_COMP	External resistor for compensation current reference
13	VS_VREG	Supply voltage for VCO voltage regulator
14	CP/VT	Charge-pump output / VCO tuning voltage input
15	REG_DEC	Decoupling pin for VCO voltage regulator
16	VREG_VCO	VCO voltage regulator output
17	VS_TRX	Supply voltage for transmitter and receiver
18	NC	Not connected
19	RX_IN2	Differential receiver input 2
20	RX_IN1	Differential receiver input 1
21	NC	Not connected
22	TX_OUT	TX driver amplifier output
23	NC	Not connected
24	RON_OUT	RXON output
25	TEST_25	Test pin
26	RX_ON	RX control input
27	TX_ON	TX control input
28	RX_DATA	RX data output
29	TEST_29	Test pin
30	CLOCK	3-wire-bus: Clock input
31	DATA	3-wire-bus: Data input
32	ENABLE	3-wire-bus: Enable input

Table 2-2. Pin Description Input/Output Circuits

Pin	Symbol	Function	Configuration
Paddle	GND	Ground	
1 26 27 29 30 31	HBS RX_ON TX_ON TEST_29 CLOCK DATA	Digital Input (internal pull down resistor)	
2	REF_CLK	Reference frequency input	
3	RSSI	Receive signal strength indicator output	
4	VS_IFA	Supply voltage for analog part of the IF circuit	
5	VS_IFD	Supply voltage for digital part of the IF circuit	
6	TEST_6	Test pin	
7	TX_MOD	Modulation input for analog TX data	

Table 2-2. Pin Description Input/Output Circuits

Pin	Symbol	Function	Configuration
8	IREF	External resistor for bias circuit	
9	NC	Not connected	
10	VS_SYND	Supply voltage for digital part of the PLL	
11	VS_SYNA	Supply voltage for analog part of the PLL	
12	I_COMP	External resistor for compensation current reference	
13	VS_VREG	Supply voltage for VCO voltage regulator	
14	CP/VT	Charge-pump output / VCO tuning voltage input	

Table 2-2. Pin Description Input/Output Circuits

Pin	Symbol	Function	Configuration
15 16	REG_DEC VREG_VCO	Decoupling pin for VCO_REG VCO voltage regulator output	
17	VS_TRX	Supply voltage for transmitter receiver	
18	NC	Not connected	
19 20	RX_IN2 RX_IN1	Differential receiver input 2 Differential receiver input 1	
21	NC	Not connected	
22	TX_OUT	TX driver amplifier output	
23	NC	Not connected	
24	RON_OUT	RXON output	

Table 2-2. Pin Description Input/Output Circuits

Pin	Symbol	Function	Configuration
25	TEST_25	Test input	
28	RX_DATA	RX data output	
32	ENABLE	3-wire-bus: Enable input (internal pullup resistor)	<p>www.DataSheet4U.com</p>

3. Functional Description

3.1 General

The 5.8 GHz transceiver supports a data rate of 1152 kBit/s.

3.2 Transmitter

The analog transmit data at TX_MOD (externally Gaussian filtered) is fed to the fully integrated VCO operating at the output frequency. The VCO signal is buffered by an internal preamplifier PA. This preamplifier supplies typically 5 dBm output power at TX_OUT.

3.3 Receiver

The receiver consists of an LNA followed by the IR_MIXER. The IR_MIXER is driven by a 0/90 degree phase shifter from the VCO. The channel filtering of the IF signal (1.728 MHz) is done in the active polyphase filter. After a limiting amplifier the signal is converted from analog to digital by an ADC. Digital signal processing extracts the frequency information and delivers receive data.

3.4 PLL

The PLL consists of a 8 bit main counter, a 5 bit swallow counter with a 32/33 modulus prescaler. The frequency/phase detector comparison frequency is 864 kHz. Open loop modulation is supported.

The VCO is fully integrated, using on-chip inductors and varactors. The output signal is buffered to the TX_PA, 0/90 degree phase shifter for the IR_MIXER and to the modulus prescaler of the PLL.

3.5 Serial Bus Programming

The transceiver is programmed by the 3-wire bus (CLOCK, DATA and ENABLE). After setting enable signal to low condition, on the rising edge of the clock signal, the data is transferred bit by bit into the shift register, starting with the MSB-bit. When the enable signal has returned to high condition, the programmed information is active. Additional leading bits are ignored and there is no check made about the number of clock pulses during enable low condition.

The programming of the transceiver is done by a 16 bit data word in Normal Mode or by a 24 bit data word in Enhanced Mode. Normal Mode uses TX_ON respectively RX_ON pin to switch on the TX respectively RX blocks. The Enhanced Mode does this internally by programming the delay time bits D16 to D23.

3.6 Power Supply

An integrated bandgap-stabilized voltage regulator supplies the VCO. Power up state is activated by the first rising edge of the CLOCK signal on the 3-wire bus interface. Power down state is activated either on the rising edge of the ENABLE signal on the 3-wire bus interface (Enhanced Mode) or by the falling edge of the TX_ON resp. RX_ON control signal (Normal Mode).

If the transceiver supply voltage is switched off e.g., by means of an external regulator, all digital inputs must be kept on low level to insure the low standby current and not to provide supply current via the ESD protection devices.

Figure 3-1. PLL Principle

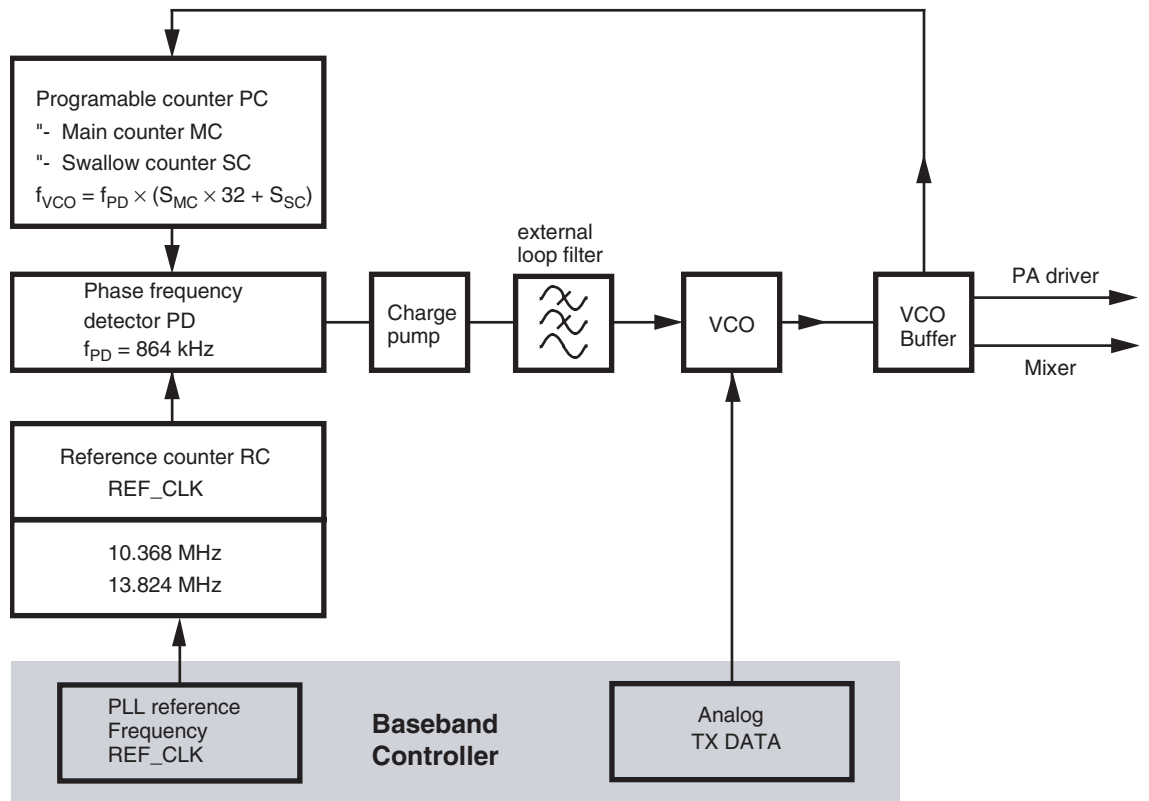

www.DataSheet4U.com

The following table shows the possible LO frequencies for RX and TX in the 5.8 GHz ISM band. There are 142 channels available. Every second channel can be used without overlap in the spectrum.

Table 3-1. Channel Table

Mode	f _{IF} /kHz	Channel	f _{ANT} /MHz	f _{VCO} /MHz	S _{MC}	S _{SC}	N
TX	-	C0	5725.728	5725.728	207	3	6627
		C1	5726.592	5726.592	207	4	6628
	
		C140	5846.688	5846.688	211	15	6767
		C141	5847.552	5847.552	211	16	6768
RX	1728	C0	5725.728	5727.456	207	5	6629
		C1	5726.592	5728.320	207	6	6630
	
		C140	5846.688	5848.416	211	17	6769
		C141	5847.552	5849.280	211	18	6770

Formula:

$$\text{TX: } f_{\text{ANT}} = f_{\text{VCO}} = 864 \text{ kHz} \times (32 \times S_{\text{MC}} + S_{\text{SC}})$$

$$\text{RX: } f_{\text{ANT}} = 864 \text{ kHz} \times (32 \times S_{\text{MC}} + S_{\text{SC}} - 2)$$

3.7 Bus Protocol Formats

3.7.1 Normal Mode

MSB														LSB	
Byte2							Byte1								
Data bits															
D15	D14	D13	D12	D11	D10	D9	D8	D7	D6	D5	D4	D3	D2	D1	D0
0	0	DR	0	0	0	TX	RC	MC			SC				

3.7.2 Enhanced Mode

MSB																				LSB			
Byte3							Byte2							Byte1									
Data bits																							
D23	D22	D21	D20	D19	D18	D17	D16	D15	D14	D13	D12	D11	D10	D9	D8	D7	D6	D5	D4	D3	D2	D1	D0
DELAY								1	1	DR	0	0	0	TX	RC	MC			SC				

3.7.3 PLL Settings

RC, MC and SC bits are controlling the PLL frequency according to [Table 3-2](#), [Table 3-3](#) and [Table 3-4](#).

Table 3-2. Reference Counter Bit D8

RC (Reference Counter)	
D8	REF_CLK
0	10.368 MHz
1	13.824 MHz

Table 3-3. Main Counter Bits D5-D7

MC (Main Counter)			
D7	D6	D5	S _{MC}
0	0	0	206
0	0	1	207
0	1	0	208
0	1	1	209
1	0	0	210
1	0	1	211
1	1	0	212
1	1	1	213

Table 3-4. Swallow Counter Bits D0-D4

SC (Swallow Counter)					
D4	D3	D2	D1	D0	S _{SC}
0	0	0	0	0	0
0	0	0	0	1	1
0	0	0	1	0	2
...
1	1	1	0	1	29
1	1	1	1	0	30
1	1	1	1	1	31

3.7.4 TX Mode ON/OFF

The TX bit is used to prepare the ATR2820 for a TX or RX slot. The transmit or receive mode is later activated by the TX_ON respectively RX_ON signal.

Table 3-5. With Bit D9

D9	TRX
0	RX
1	TX

3.7.5 Data Recovery

The DR bit switches the internal data recovery circuit on.

Table 3-6. With Bit D13

D13	Data Recovery
0	off
1	on

3.7.6 TX_ON / RX_ON Delay for Enhanced Interface Mode

The DELAY bits set the internal delay time. The delay counter is starting with the ENABLE high edge at the end of the programming.

$$\text{Delay Time: } T_{\text{Delay}} = \text{DELAY} \times 2.315 \mu\text{s}$$

The minimum delay time is 70 μs , which corresponds to a Delay value of 31.

Table 3-7. Delay Setting

D23	D22	D21	D20	D19	D18	D17	D16	DELAY
0	0	0	1	1	1	1	1	31
0	0	1	0	0	0	0	1	32
...								
1	1	1	1	1	1	1	0	254
1	1	1	1	1	1	1	1	255

3.8 3-wire Bus Protocol Timing

Figure 3-2. 3-wire Bus Protocol Timing Diagram

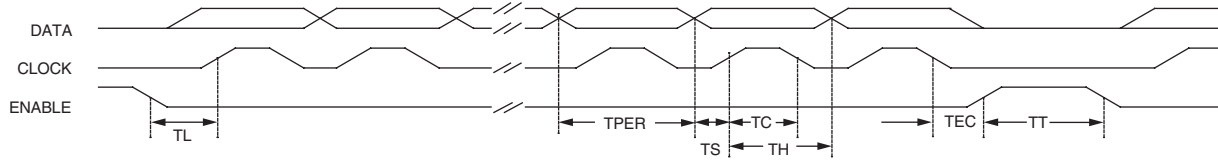

Table 3-8. 3-wire bus Protocol Table

Description	Symbol	Minimum Value	Unit
Clock period	TPER	100	ns
Set time data to clock	TS	20	ns
Hold time data to clock	TH	20	ns
Clock pulse width	TC	60	ns
Set time enable to clock	TL	100	ns
Hold time enable to data	TEC	0	ns
Time between two protocols	TT	250	ns

3.9 Control Signals

www.DataSheet4U.com

Table 3-9. Control Signals – Functions

Signal	Functions
RX_ON (external or internal signal)	Activates RX circuits: LNA, IR MIXER, BP, LIMITER, DEMOD
TX_ON (external or internal signal)	Activates TX circuit: PA
HBS	Selects the handset or basemode: Low = Handset, High = Basemode

4. Absolute Maximum Ratings

Stresses beyond those listed under “Absolute Maximum Ratings” may cause permanent damage to the device. This is a stress rating only and functional operation of the device at these or any other conditions beyond those indicated in the operational sections of this specification is not implied. Exposure to absolute maximum rating conditions for extended periods may affect device reliability.

Parameters	Symbol	Min.	Max.	Unit
Supply voltage	V_S	-0.3	+3.6	V
Control voltages	V_{contr}	-0.3	V_S	V
Junction temperature	T_{jmax}		125	°C
Storage temperature	T_{stg}	-40	+125	°C
Input RF level	P_{RF}		10	dBm
ESD protection	$V_{\text{ESD_anal}}$		TBD	V
	$V_{\text{ESD_dig}}$		TBD	V

5. Thermal Resistance

Parameters	Symbol	Value	Unit
Junction ambient	R_{thJA}	TBD	K/W

6. Handling

Do not operate this part near strong electrostatic fields. This IC meets class 0 ESD test requirement (HBM in accordance to EIA/JESD22-A114-A (October 97)).

www.DataSheet4U.com

7. Operating Range

Parameters	Symbol	Min.	Max.	Unit
Supply voltage	V_S	2.9	3.6	V
Temperature ambient	T_{amb}	-10	+60	°C

8. Electrical Characteristics

$V_S = 3.2V$, $T_{amb} = 25^\circ C$, unless otherwise specified.

Parameters	Test Conditions	Symbol	Min.	Typ.	Max.	Unit	Type*
Supply							
Supply voltage		V_S	2.9	3.2	3.6	V	D
PLL supply current		I_S		25		mA	A
RX supply current		I_S		65		mA	A
TX supply current		I_S		22		mA	A
Supply current in power-down mode		I_S		< 1		μA	A
PLL							
Scaling factor prescaler		S_{PSC}	32/33				A
Scaling factor main counter		S_{MC}	206, 207, ..., 212, 213				A
Scaling factor swallow counter		S_{SC}	0 ... 31				A
Scaling factor reference counter	RC = 0, 1	S_{RC}	12, 16				A
External reference input frequency	RC = 0 RC = 1	Ref_CLK		10.368 13.824		MHz MHz	A
Sinusoidal input signal level	AC coupled sinewave	Ref_CLK	500		1200	mV _{P-P}	A
Phase detector comparison frequency		f_{PD}	864			kHz	A
Charge-pump output current	$V_{CP} = 1/2 V_S$	I_{CP}		± 2		mA	A
Leakage current	$V_{CP} = 1/2 V_S$	I_L		± 100		pA	A
<small>www.DataSheet4U.com</small>							
VCO							
Oscillator frequency	Over full temperature range ⁽¹⁾		5725		5875	MHz	A
Frequency control voltage range		V_{VTUNE}	0.5		$V_S - 0.5$	V	A
VCO tuning input gain	Defined at TX output ⁽¹⁾	G_{VCO}		120		MHz/V	A
Modulation control voltage range		V_{TX_MOD}	0		V_S	V	A
Modulation input gain	DC bias: $V_{TX_MOD} = 750$ mV Defined at TX output ⁽¹⁾	G_{TX_MOD}		800		kHz/V	A
VCO phase noise	PN at 1 MHz offset			-105	-100	dBc/Hz	C
Transmitter							
TX data rate			1152			kBit/s	C
Frequency deviation	Analog modulation signal at TX_MOD		± 400			kHz	A
TX preamplifier output power	Over full temperature range, from 5725 MHz to 5875 MHz ⁽¹⁾	P_{TX}	0	5		dBm	A
TX output impedance		Z_{OUT}	24-j107			Ω	C
Frequency drift during a slot	400 μs slot length	Δf_o (drift)			± 20	kHz	C

*) Type means: A = 100% tested, B = 100% correlation tested, C = Characterized on samples, D = Design parameter

Note: 1. Measured and guaranteed only on the Atmel evaluation board.

8. Electrical Characteristics (Continued)

$V_S = 3.2V$, $T_{amb} = 25^\circ C$, unless otherwise specified.

Parameters	Test Conditions	Symbol	Min.	Typ.	Max.	Unit	Type*
Receiver							
RX input frequency range		f_{RX}	5725		5875	MHz	C
RX input impedance	Differential	Z_{IN}	94-j3			Ω	C
Sensitivity at input for BER $\leq 10^{-3}$	$f_{dev} = 400 \text{ kHz}^{(1)}$ at 1152 kBit/s	S		-97		dBm	C
Third order input intercept point		IIP3		-15		dBm	C
Intermodulation rejection	BER $< 10^{-3}$, wanted at -83 dBm, level of interferers in channels N-2 and N-4 ⁽¹⁾	IM_3	32			dBc	C
Co-channel rejection	BER $< 10^{-3}$, wanted at -76 dBm ⁽¹⁾	R_{CO}	-11	-7		dBc	C
Adjacent channel rejection $\pm 1.728 \text{ MHz}$	BER $< 10^{-3}$, wanted at -76 dBm, adjacent level referred to wanted channel level ⁽¹⁾	$R_{i(N \pm 1)}$	13	19		dBc	C
Bi-adjacent channel rejection +3.456 MHz (Image frequency) -3.456 MHz	BER $< 10^{-3}$, wanted at -76 dBm, bi-adjacent level referred to wanted channel level ⁽¹⁾	$R_{i(N \pm 2)}$	13 34	19 43		dBc	C
Rejection with ≥ 3 channels separation $\geq \pm 5.128 \text{ MHz}$	BER $< 10^{-3}$, wanted at -76 dBm, $n \geq 3$ adjacent level referred to wanted channel level ⁽¹⁾	$R_{i(n \pm \geq 3)}$	40	46		dBc	C
Out of band rejection $> 6 \text{ MHz}$	BER $< 10^{-3}$, wanted at -83 dBm at 5.8 GHz ⁽¹⁾	$Bl_{df>6MHz}$	38	53		dBc	C
Out of band rejection 5670 MHz to 5690 MHz 5881 MHz to 5900 GHz	BER $< 10^{-3}$, wanted at -83 dBm at 5.8 GHz ⁽¹⁾	Bl_{near}	47	58		dBc	C
Out of band rejection 30 MHz to 5670 MHz 5900 MHz to 8GHz	BER $< 10^{-3}$, wanted at -83 dBm at 5.8 GHz ⁽¹⁾	Bl_{far}	54	65		dBc	C
Maximum RSSI output voltage	Under high RX input signal level	$V_{RSSImax}$		1.9		V	A
RSSI output voltage, monotonic over range -96 dBm to -36 dBm	with -33 dBm at RF input with -96 dBm at RF input	V_{RSSI}		1.7 0.1		V V	A
Wake-up time from power-up signal to correct RSSI output	150 pF load on RSSI output pin 3	T_{on}		20	40	μs	C
Interface Logic Input and Output Signal Levels, Pins DATA, CLOCK, ENABLE, RX_ON, TX_ON, RX_DATA, HBS							
HIGH-level input voltage	Logic 1	V_{IH}	1.4		V_S	V	A
LOW-level input voltage	Logic 0	V_{IL}	-0.3		+0.4	V	A
HIGH-level output voltage	Logic 1	V_{OH}			V_S	V	A
LOW-level output voltage	Logic 0	V_{OL}	0			V	A
Input bias current	Logic 1 or logic 0	I_{bias}	-5		+5	μA	A
Maximum 3-wire bus frequency		f_{CLKmax}	10			MHz	C
Output Pin RON_OUT							
LOW-level output voltage	$I_{SINK} = 10 \text{ mA}$	V_{OL}			0.5	V	A
High-level output current	$V_{OL} = 2.7V$	I_{OL}		100	120	μA	A

*) Type means: A = 100% tested, B = 100% correlation tested, C = Characterized on samples, D = Design parameter

Note: 1. Measured and guaranteed only on the Atmel evaluation board.



9. Application

Figure 9-1. Application Circuit

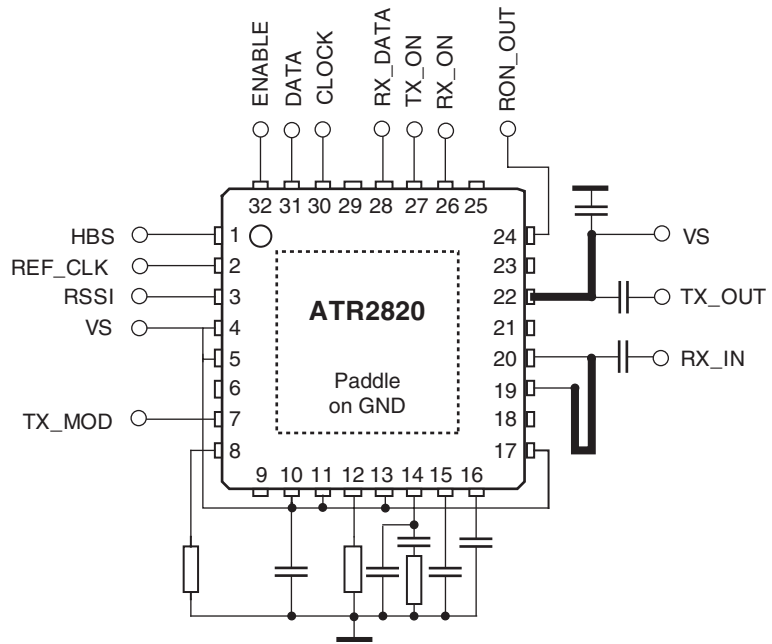

www.DataSheet4U.com

Figure 9-2. TX Timing (Normal Mode)

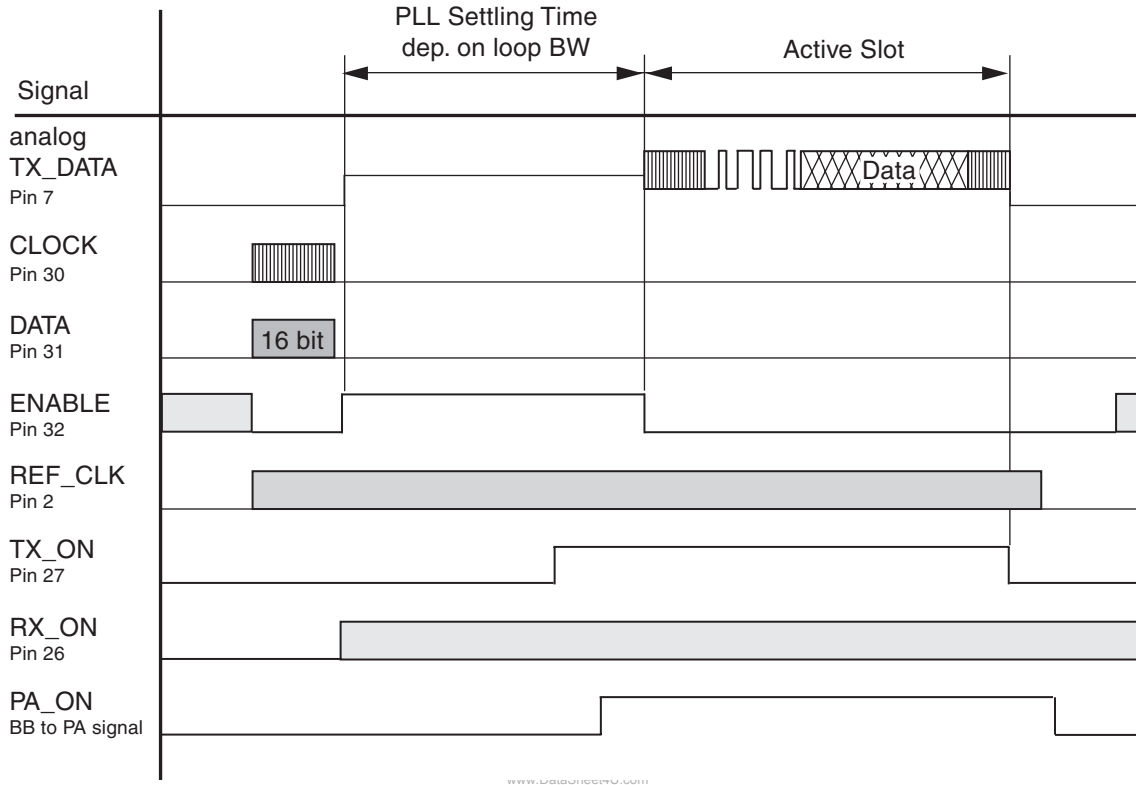

TX Control Sequence Normal Mode:

- Programming of 3 wire bus (16bit word)
- First rising edge of CLOCK signal activates power up mode of TRX
- TX_ON high signal ($\approx 100 \mu\text{s}$ before active slot) activates TX PreAmplifier
- PA_ON high signal ($\approx 50 \mu\text{s}$ before active slot) activates external Power Amplifier (e.g. ATR7040)
- ENABLE low signal activates open loop mode of PLL
- Start of Analog Modulation
- TX_ON low signal deactivates TX PreAmplifier and sets TRX in power down
- PA_ON low signal turns external Power Amplifier off

Remark:

- Minimum distance between different signal edges $> 4 \mu\text{s}$
- REF_CLK must be active before the first CLOCK edge and at least 4 us after TX_ON low signal

Figure 9-3. RX Timing (Normal Mode)

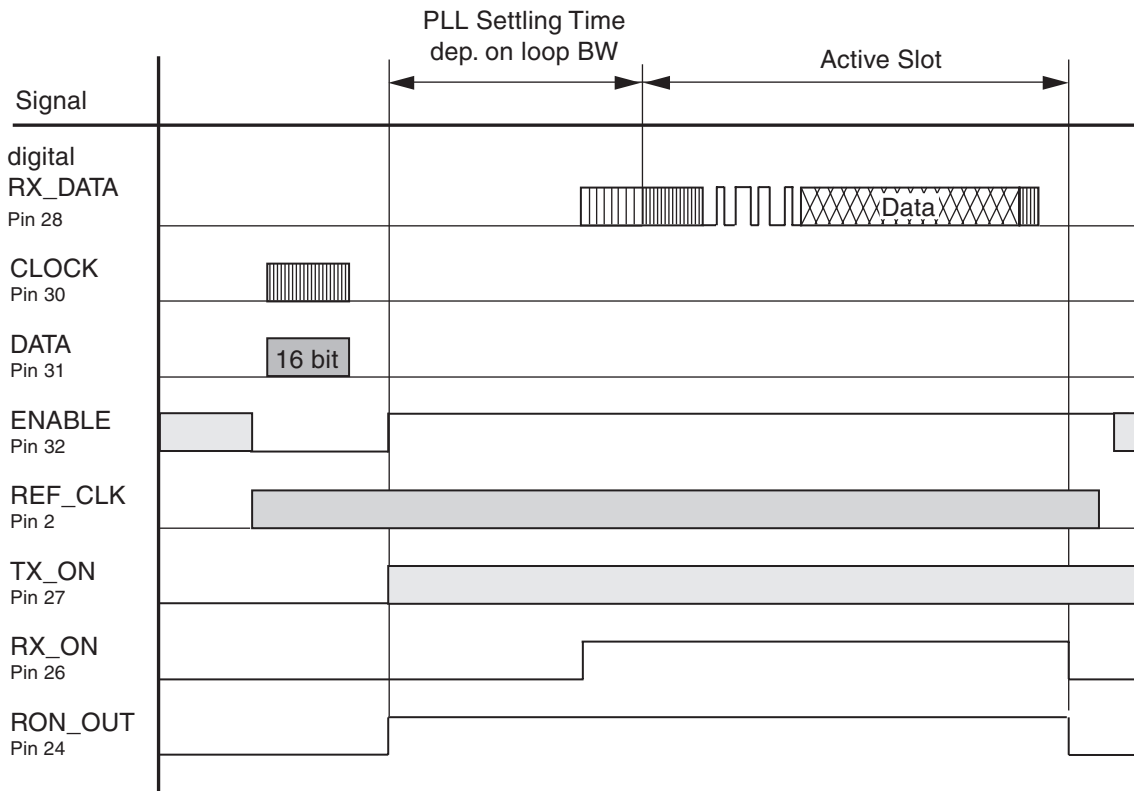

RX Control Sequence Normal Mode:

- Programming of 3 wire bus (16 bit word)
- First rising edge of CLOCK signal activates power up mode of TRX
- RON_OUT output signal can be used to switch external LNA on
- RX_ON high signal ($\approx 50 \mu\text{s}$ before active slot) activates RX blocks
- RX_DATA (digital) is delivered $25 \mu\text{s}$ after RX_ON high
- RX_ON low signal deactivates RX blocks and sets TRX in power down

Remark:

- Minimum distance between different signal edges $> 4 \mu\text{s}$
- REF_CLK must be active before the first CLOCK edge and at least $4 \mu\text{s}$ after TX_ON low signal

Figure 9-4. TX Timing (Enhanced Mode)

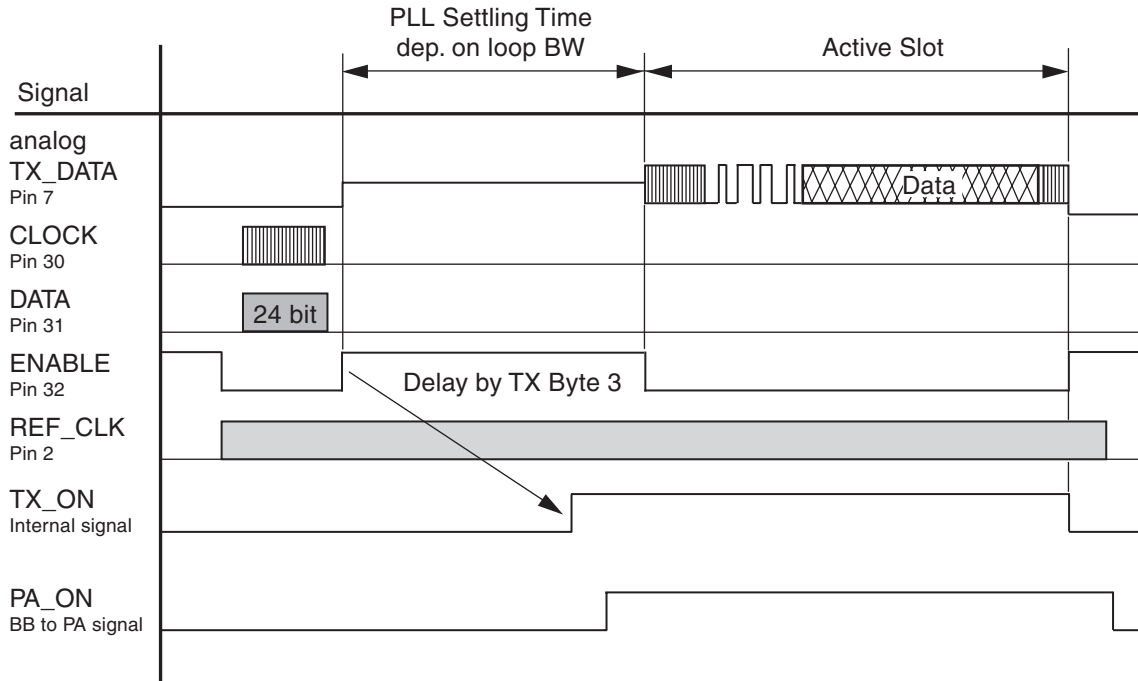

TX Control Sequence Enhanced Mode:

- Programming of 3 wire bus (24 bit word)
- First rising edge of CLOCK signal activates power up mode of TRX
- Internal TX_ON high signal ($\approx 100 \mu\text{s}$ before active slot defined by TX Byte 3) activates TX PreAmplifier
- PA_ON high signal ($\approx 50 \mu\text{s}$ before active slot) activates external Power Amplifier (e.g. ATR7040)
- ENABLE low signal activates open loop mode of PLL
- Start of Analog Modulation
- ENABLE high signal deactivates TX PreAmplifier and sets TRX in power down
- PA_ON low signal turns external Power Amplifier off

Remark:

- Minimum distance between different signal edges $> 4 \mu\text{s}$
- REF_CLK must be active before the first CLOCK edge and at least $4 \mu\text{s}$ after ENABLE high signal

Figure 9-5. RX Timing (Enhanced Mode)

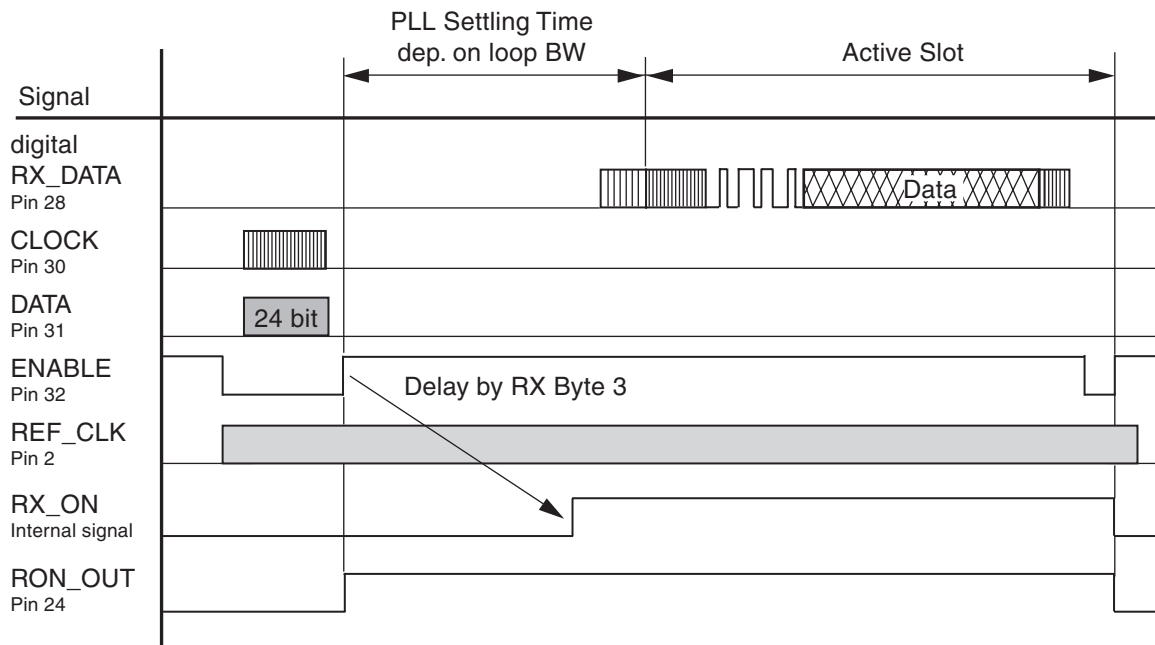

RX Control Sequence Enhanced Mode:

- Programming of 3 wire bus (24 bit word)
- First rising edge of CLOCK signal activates power up mode of TRX
- RON_OUT output signal can be used to switch external LNA on
- Internal RX_ON high signal ($\approx 50 \mu\text{s}$ before active slot defined by RX Byte 3) activates RX blocks
- RX_DATA (digital) is delivered $25 \mu\text{s}$ after internal RX_ON high
- Rising edge of ENABLE low pulse signal deactivates RX blocks and sets TRX in power down

Remark:

- Minimum distance between different signal edges $> 4 \mu\text{s}$
- REF_CLK must be active before the first CLOCK edge and at least $4 \mu\text{s}$ after TX_ON low signal

10. Ordering Information

Extended Type Number	Package	Remarks
ATR2820-PNQG	QFN32, 5 mm x 5 mm	Taped and reeled

11. Package Information

Package: QFN 32 - 5 x 5
 Exposed pad 3.15 x 3.15
 (acc. JEDEC OUTLINE No. MO-220)

Dimensions in mm

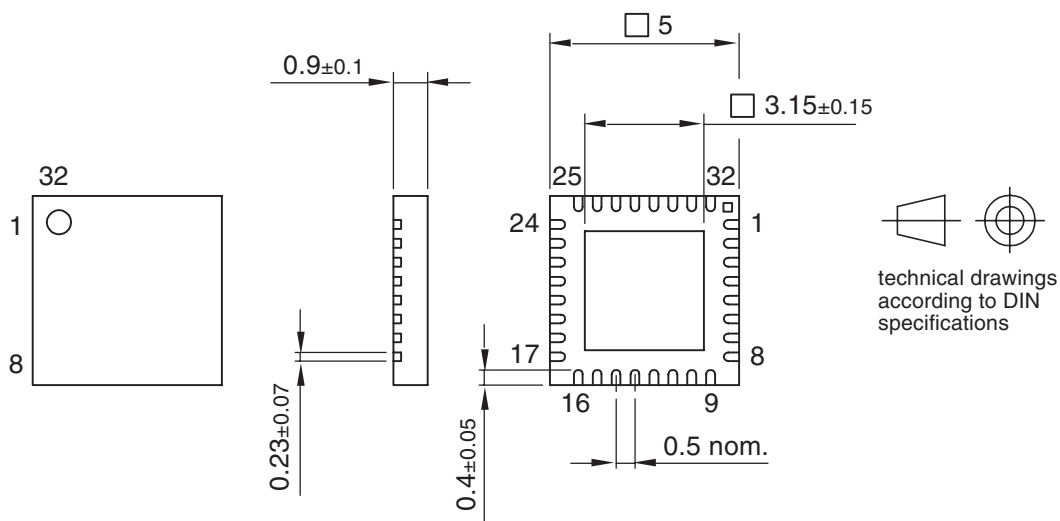

Drawing-No.: 6.543-5087.01-4

Issue: 2; 24.01.03



Atmel Corporation

2325 Orchard Parkway
San Jose, CA 95131, USA
Tel: 1(408) 441-0311
Fax: 1(408) 487-2600

Regional Headquarters

Europe

Atmel Sarl
Route des Arsenaux 41
Case Postale 80
CH-1705 Fribourg
Switzerland
Tel: (41) 26-426-5555
Fax: (41) 26-426-5500

Asia

Room 1219
Chinachem Golden Plaza
77 Mody Road Tsimshatsui
East Kowloon
Hong Kong
Tel: (852) 2721-9778
Fax: (852) 2722-1369

Japan

9F, Tonetsu Shinkawa Bldg.
1-24-8 Shinkawa
Chuo-ku, Tokyo 104-0033
Japan
Tel: (81) 3-3523-3551
Fax: (81) 3-3523-7581

Atmel Operations

Memory

2325 Orchard Parkway
San Jose, CA 95131, USA
Tel: 1(408) 441-0311
Fax: 1(408) 436-4314

Microcontrollers

2325 Orchard Parkway
San Jose, CA 95131, USA
Tel: 1(408) 441-0311
Fax: 1(408) 436-4314

La Chantrerie
BP 70602
44306 Nantes Cedex 3, France
Tel: (33) 2-40-18-18-18
Fax: (33) 2-40-18-19-60

ASIC/ASSP/Smart Cards

Zone Industrielle
13106 Rousset Cedex, France
Tel: (33) 4-42-53-60-00
Fax: (33) 4-42-53-60-01

1150 East Cheyenne Mtn. Blvd.
Colorado Springs, CO 80906, USA
Tel: 1(719) 576-3300
Fax: 1(719) 540-1759

Scottish Enterprise Technology Park
Maxwell Building
East Kilbride G75 0QR, Scotland
Tel: (44) 1355-803-000
Fax: (44) 1355-242-743

RF/Automotive

Theresienstrasse 2
Postfach 3535
74025 Heilbronn, Germany
Tel: (49) 71-31-67-0
Fax: (49) 71-31-67-2340

1150 East Cheyenne Mtn. Blvd.
Colorado Springs, CO 80906, USA
Tel: 1(719) 576-3300
Fax: 1(719) 540-1759

Biometrics/Imaging/Hi-Rel MPU/ High-Speed Converters/RF Datacom

Avenue de Rochepleine
BP 123
38521 Saint-Egreve Cedex, France
Tel: (33) 4-76-58-30-00
Fax: (33) 4-76-58-34-80

Literature Requests

www.atmel.com/literature

Disclaimer: The information in this document is provided in connection with Atmel products. No license, express or implied, by estoppel or otherwise, to any intellectual property right is granted by this document or in connection with the sale of Atmel products. **EXCEPT AS SET FORTH IN ATMEL'S TERMS AND CONDITIONS OF SALE LOCATED ON ATMEL'S WEB SITE, ATMEL ASSUMES NO LIABILITY WHATSOEVER AND DISCLAIMS ANY EXPRESS, IMPLIED OR STATUTORY WARRANTY RELATING TO ITS PRODUCTS INCLUDING, BUT NOT LIMITED TO, THE IMPLIED WARRANTY OF MERCHANTABILITY, FITNESS FOR A PARTICULAR PURPOSE, OR NON-INFRINGEMENT. IN NO EVENT SHALL ATMEL BE LIABLE FOR ANY DIRECT, INDIRECT, CONSEQUENTIAL, PUNITIVE, SPECIAL OR INCIDENTAL DAMAGES (INCLUDING, WITHOUT LIMITATION, DAMAGES FOR LOSS OF PROFITS, BUSINESS INTERRUPTION, OR LOSS OF INFORMATION) ARISING OUT OF THE USE OR INABILITY TO USE THIS DOCUMENT, EVEN IF ATMEL HAS BEEN ADVISED OF THE POSSIBILITY OF SUCH DAMAGES.** Atmel makes no representations or warranties with respect to the accuracy or completeness of the contents of this document and reserves the right to make changes to specifications and product descriptions at any time without notice. Atmel does not make any commitment to update the information contained herein. Unless specifically provided otherwise, Atmel products are not suitable for, and shall not be used in, automotive applications. Atmel's products are not intended, authorized, or warranted for use as components in applications intended to support or sustain life.

© 2006 Atmel Corporation. All rights reserved. Atmel®, logo and combinations thereof, Everywhere You Are® and others are registered trademarks or trademarks of Atmel Corporation or its subsidiaries. Other terms and product names may be trademarks of others.