



Your Total LCD Solution Provider

<http://www.orientdisplay.com>

SPECIFICATION FOR LCD MODULE

MODULE NO: AFD480272A1T-4.3N6WTM
VERSION NO.: V1.0

Customer's Approval:

--

	SIGNATURE	DATE
PREPARED BY		
CHECKED BY		
APPROVED BY		

RECORD OF REVISION

Version	Revised Date	Page	Content
V1.0	2013/11/26	--	First Issued

TABLE OF CONTENTS

No.	Content	Page
	TFT Module Specification	1
	RECORD OF REVISION	2
	TABLE OF CONTENTS	3
1.	GENERAL DESCRIPTION.....	4
2.	MECHANICAL SPECIFICATION	5
3.	PIN DESCRIPTION	6
4.	ABSOLUTE MAXIMUM RATINGS	8
5.	BLOCK DIAGRAM.....	9
6.	RELATIONSHIP BETWEEN DISPLAYED COLOR AND INPUT.....	10
7.	ELECTRICAL CHARACTERISTICS.....	11
8.	OPTICAL CHARACTERISTICS	15
9.	RELIABILITY	18
10.	PRECAUTION RELATING PRODUCT HANDLING.....	23

1. GENERAL DESCRIPTION

1.1 Description

The specifications is model AFD480272A1T-4.3N6WTM is a color active matrix thin film transistor (TFT) liquid crystal display (LCD) that uses amorphous silicon TFT as a switching device. This model is composed of a TFT LCD panel, a driving circuit, a back light system. This TFT LCD has a 4.3 (16:9) inch diagonally measured active display area with WQVGA (480 horizontal by 272 vertical pixels) resolution.

1.2 Features:

No.	Item	Specification	Unit
1	Panel Size	4.3"	Inch
2	Number of Pixels	480 (W) x RGB x 272 (H)	Pixels
3	Active Area	95.04 (W) × 53.856 (H)	mm
4	Pixel Pitch	0.198 (W) x 0.198(H)	mm
5	Outline Dimension	105.5 (W) × 67.2 (H) × 2.9 (T)	mm
6	Number of Colors	16.7M	--
7	Display Mode	TN / Normally White / Transmissive	--
8	View Direction	6 o'clock(Gray Inversion)	
9	Display Format	RGB vertical stripe	--
10	Surface Treatment	Anti-Glare	--
11	Contrast Ratio	600 (Typ.)	--
12	Luminance (cd/m ²)	500 (Typ.)	cd/m ²
13	Interface	RGB 24bit Interface	--
14	Backlight	White LED	--
15	Driver IC	--	--
16	Operation Temperature	-20 ~ 70	°C
17	Storage Temperature	-30 ~ 80	°C
18	Weight	(45)	g

2. MECHANICAL SPECIFICATION

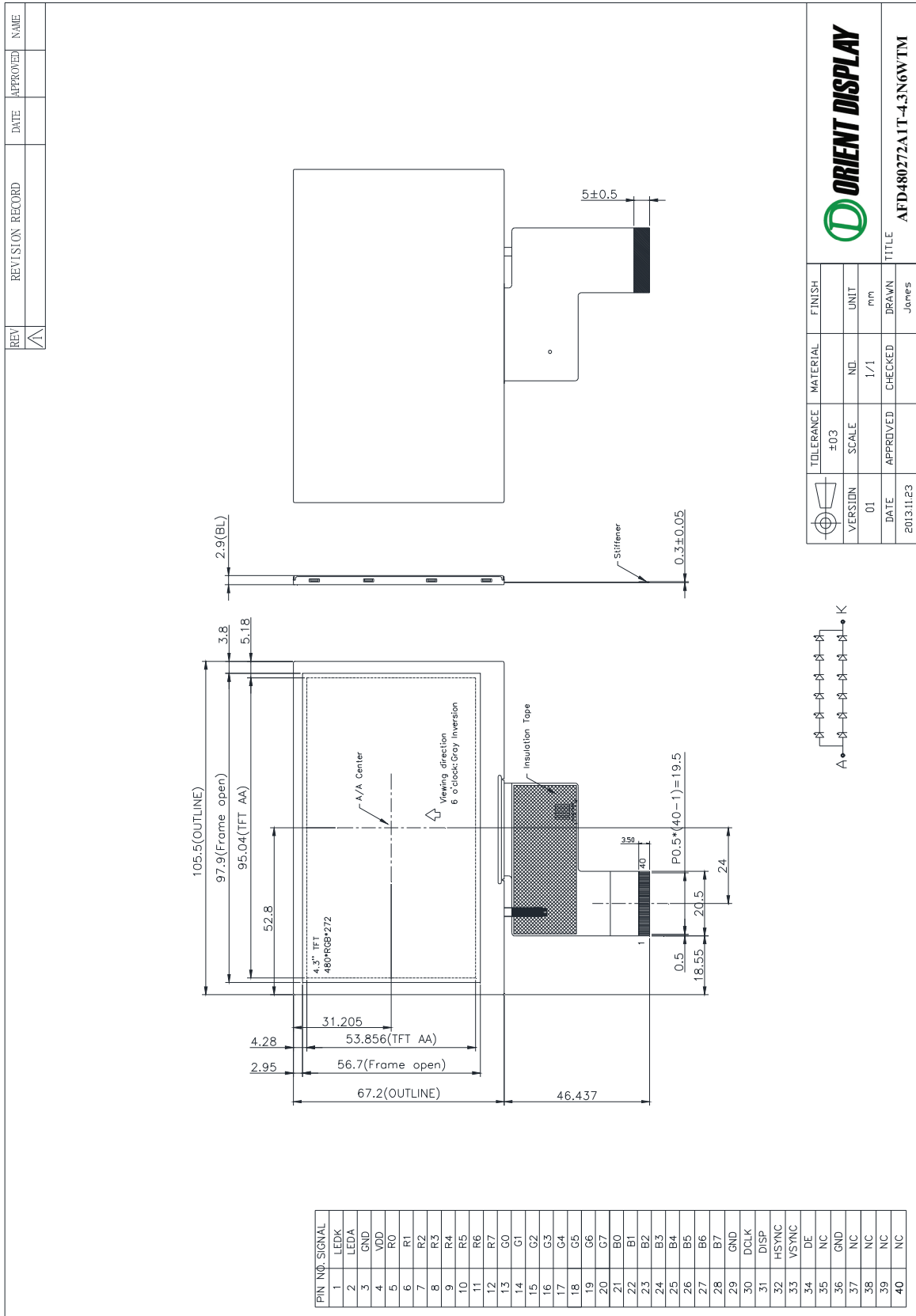

TOLERANCE	MATERIAL	FINISH
±0.3		
VERSION	NO.	UNIT
01	1/1	mm
DATE	APPROVED	CHECKED
2013.11.23		Jones
TITLE		
AFD480272A1T-4.3N6WTFM		

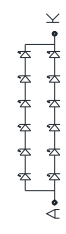

3. PIN DESCRIPTION

Pin No.	Symbol	I/O	Function	Remark
1	VLED-	P	Power for LED backlight cathode	
2	VLED+	P	Power for LED backlight anode	
3	GND	P	Power Ground	
4	VDD	P	Power Supply	
5	R0	I	Red data signal (LSB)	
6	R1	I	Red data signal	
7	R2	I	Red data signal	
8	R3	I	Red data signal	
9	R4	I	Red data signal	
10	R5	I	Red data signal	
11	R6	I	Red data signal	
12	R7	I	Red data signal (MSB)	
13	G0	I	Green data signal (LSB)	
14	G1	I	Green data signal	
15	G2	I	Green data signal	
16	G3	I	Green data signal	
17	G4	I	Green data signal	
18	G5	I	Green data signal	
19	G6	I	Green data signal	
20	G7	I	Green data signal (MSB)	
21	B0	I	Blue data signal (LSB)	
22	B1	I	Blue data signal	
23	B2	I	Blue data signal	
24	B3	I	Blue data signal	
25	B4	I	Blue data signal	
26	B5	I	Blue data signal	
27	B6	I	Blue data signal	
28	B7	I	Blue data signal (MSB)	
29	DGND	P	Digital ground	
30	DCLK	I	Pixel clock	
31	DISP	I	Display on/ off	
32	HSYNC	I	Horizontal sync signal	
33	VSYNC	I	Vertical sync signal	
34	DE	I	Data Enable signal	
35	NC	-	No Connect	

36	GND	P	Power Ground	
37	NC	-	No Connect	
38	NC	-	No Connect	
39	NC	-	No Connect	
40	NC	-	No Connect	

4. ABSOLUTE MAXIMUM RATINGS

4.1 Electrical Absolute Rating

4.1.1 TFT LCD Module

Item	Symbol	Values		Unit	Note
		Min	Max.		
Power supply voltage	VDD	-0.3	5.0	V	

4.1.2 Environment Absolute Rating

Item	Symbol	Values			Unit	Note
		Min	Typ	Max.		
Operating Temperature	Topa	-20		70	°C	Ambient temperature
Storage Temperature	Tstg	-30		80	°C	

5. BLOCK DIAGRAM
5.1 TFT LCD Module

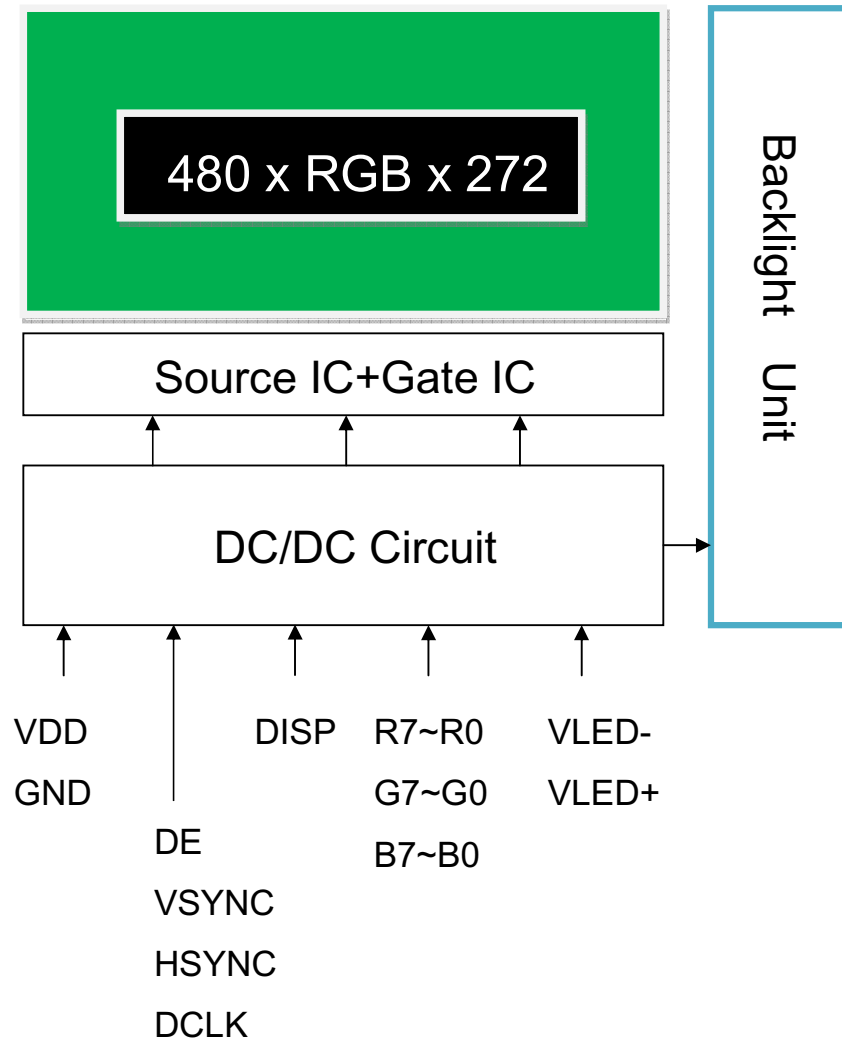

6. Relationship Between Displayed Color and Input

6.1 8 bit

	Color & Gray Scale	Data Signal																							
		R7	R6	R5	R4	R3	R2	R1	R0	G7	G6	G5	G4	G3	G2	G1	G0	B7	B6	B5	B4	B3	B2	B1	B0
Basic Color	Black	0	0	0	0	0	0	0	0	0	0	0	0	0	0	0	0	0	0	0	0	0	0	0	
	Red	1	1	1	1	1	1	1	1	0	0	0	0	0	0	0	0	0	0	0	0	0	0	0	
	Green	0	0	0	0	0	0	0	0	1	1	1	1	1	1	1	1	0	0	0	0	0	0	0	
	Blue	0	0	0	0	0	0	0	0	0	0	0	0	0	0	0	0	1	1	1	1	1	1	1	
	Cyan	0	0	0	0	0	0	0	0	1	1	1	1	1	1	1	1	1	1	1	1	1	1	1	
	Magenta	1	1	1	1	1	1	1	1	0	0	0	0	0	0	0	0	1	1	1	1	1	1	1	
	Yellow	1	1	1	1	1	1	1	1	1	1	1	1	1	1	1	1	0	0	0	0	0	0	0	
	White	1	1	1	1	1	1	1	1	1	1	1	1	1	1	1	1	1	1	1	1	1	1	1	
Red	Black	0	0	0	0	0	0	0	0	0	0	0	0	0	0	0	0	0	0	0	0	0	0		
	Red(1)	0	0	0	0	0	0	0	1	0	0	0	0	0	0	0	0	0	0	0	0	0	0		
	Red(2)	0	0	0	0	0	0	1	0	0	0	0	0	0	0	0	0	0	0	0	0	0	0		
	:	:	:	:	:	:	:	:	:	:	:	:	:	:	:	:	:	:	:	:	:	:	:		
	Red(127)	0	1	1	1	1	1	1	1	0	0	0	0	0	0	0	0	0	0	0	0	0	0		
	:	:	:	:	:	:	:	:	:	:	:	:	:	:	:	:	:	:	:	:	:	:	:	:	
	Red(255)	1	1	1	1	1	1	1	1	0	0	0	0	0	0	0	0	0	0	0	0	0	0		
Red(255)	1	1	1	1	1	1	1	1	0	0	0	0	0	0	0	0	0	0	0	0	0	0			
Green	Black	0	0	0	0	0	0	0	0	0	0	0	0	0	0	0	0	0	0	0	0	0	0		
	Green(1)	0	0	0	0	0	0	0	0	0	0	0	0	0	0	0	1	0	0	0	0	0	0		
	Green(2)	0	0	0	0	0	0	0	0	0	0	0	0	0	0	1	0	0	0	0	0	0	0		
	:	:	:	:	:	:	:	:	:	:	:	:	:	:	:	:	:	:	:	:	:	:	:		
	Green(127)	0	0	0	0	0	0	0	0	0	1	1	1	1	1	1	1	0	0	0	0	0	0		
	:	:	:	:	:	:	:	:	:	:	:	:	:	:	:	:	:	:	:	:	:	:	:		
	Green(255)	0	0	0	0	0	0	0	0	1	1	1	1	1	1	1	1	0	0	0	0	0	0		
Green(255)	0	0	0	0	0	0	0	0	1	1	1	1	1	1	1	1	0	0	0	0	0	0			
Blue	Black	0	0	0	0	0	0	0	0	0	0	0	0	0	0	0	0	0	0	0	0	0	0		
	Blue(1)	0	0	0	0	0	0	0	0	0	0	0	0	0	0	0	0	0	0	0	0	0	1		
	Blue(2)	0	0	0	0	0	0	0	0	0	0	0	0	0	0	0	0	0	0	0	0	0	1		
	:	:	:	:	:	:	:	:	:	:	:	:	:	:	:	:	:	:	:	:	:	:	:		
	Blue(127)	0	0	0	0	0	0	0	0	0	0	0	0	0	0	0	0	0	1	1	1	1	1		
	:	:	:	:	:	:	:	:	:	:	:	:	:	:	:	:	:	:	:	:	:	:	:		
	Blue(255)	0	0	0	0	0	0	0	0	0	0	0	0	0	0	0	0	1	1	1	1	1	1		
Blue(255)	0	0	0	0	0	0	0	0	0	0	0	0	0	0	0	0	1	1	1	1	1	1			

0 : Low level voltage, 1 : High level voltage

Each basic color can be displayed in 256 gray scales from 8 bit data signals. With the combination of total 24 bit data signals, the 16,777,216-color display can be achieved on the screen.

7. ELECTRICAL CHARACTERISTICS

7.1 TFT LCD Module

Item	Symbol	Value			Unit	Note
		Min.	Typ.	Max.		
Power supply voltage	VDD	3.0	3.3	3.6	V	
Input Voltage for logic	H Level	VIH	0.7xVDD	-	VDD	V
	L Level	VIL	0	-	0.3xVDD	V
Digital Current	IDD	-	(4.2)	-	mA	Note1

Note 1: frame =60Hz , Ta=25°C , Display pattern : Black pattern



7.2 Backlight Unit

Item	Symbol	Value			Unit	Condition
		Min.	Typ.	Max.		
LED Voltage	VL	(18)	(19.2)	(20.4)	V	
LED Current	If	-	(40)	-	mA	6S2P
Power Consumption	PBL	-	768	-	mW	
LED Life Time (25°C)	-	(20000)	-	-	hr	(1)

Note (1): The “LED life time” is defined as the module brightness decrease to 50% original brightness that the ambient temperature is 25°C 60% RH.

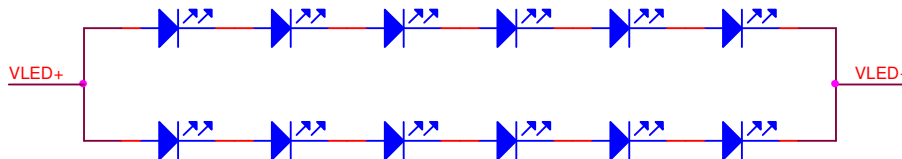

7.3 INTERFACE SPECIFICATIONS

7.3.1 Timing characteristics

Signal	Parameter	Symbol	Min.	Typ.	Max.	Unit.	Note
DCLK	DCLK cycle time	Tcph	83.3	111.1	200	ns	
	DCLK Frequency	fclk	5	9	12	MHz	
	DCLK High plus width	Tcwh	40	50	60	%	
Horizontal	HSD setup time	Thst	12	-	-	ns	
	HSD hold time	Thhd	12	-	-	ns	
	Horizontal display area	thd	-	480	-	Tcph	
	HSD period time	th	520	525	800	Tcph	
	HSD pulse width	thpw	1	-	-	Tcph	
	HSD back porch	thb	36	40	255	Tcph	
	HSD front porch	thfp	4	5	65	Tcph	
Vertical	VSD setup time	Tvst	12	-	-	ns	
	VSD hold time	Tvhd	12	-	-	ns	
	Vertical display area	tvd	-	272	-	th	
	VSD period time	tv	-	288	-	th	
	VSD pulse width	tvpw	1	-	-	th	
	VSD back porch	tvb	3	8	31	th	
	VSD front porch	tvfp	2	8	93	th	
DE	DE setup time	Tesu	12	-	-	ns	
	DE hold time	Tehd	12	-	-	ns	
DATA	Data setup time	Tdsu	12	-	-	ns	
	Data hold time	Tdhd	12	-	-	ns	

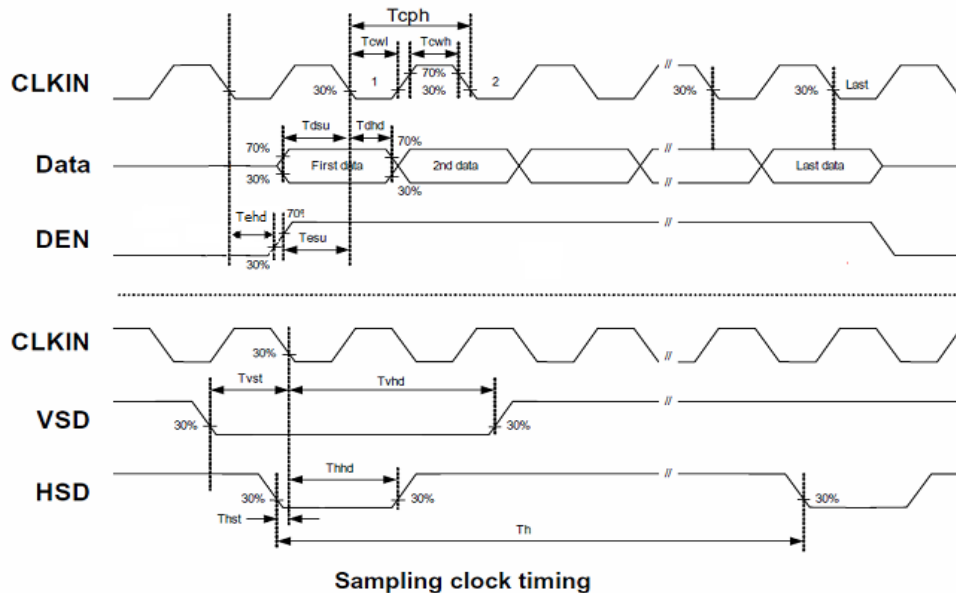

7.3.2 Input Timing Table

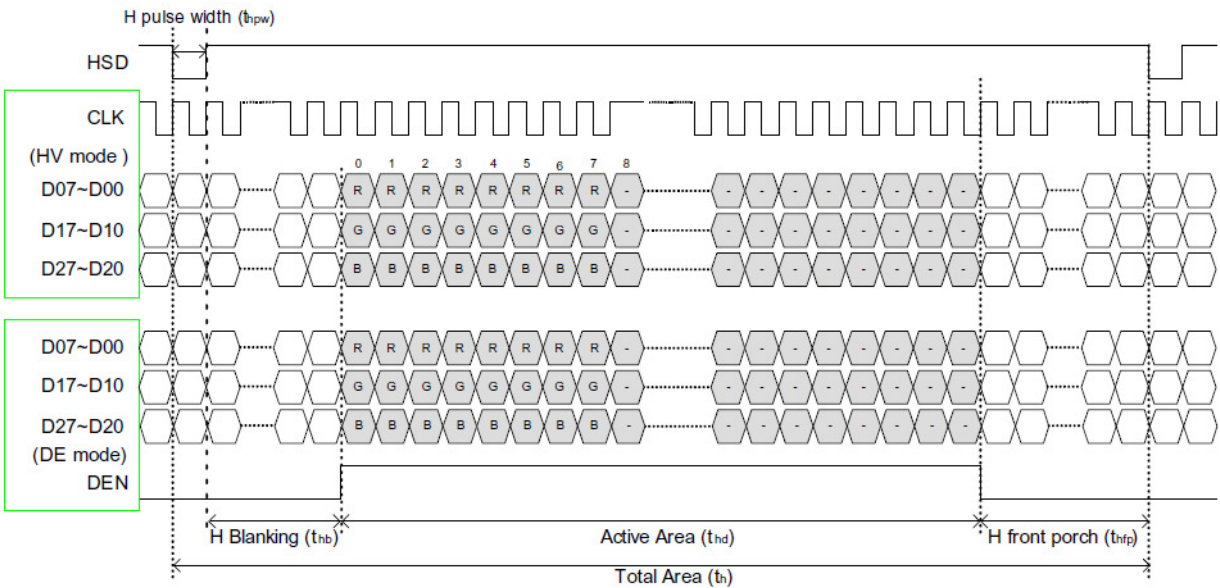

Horizontal display timing range

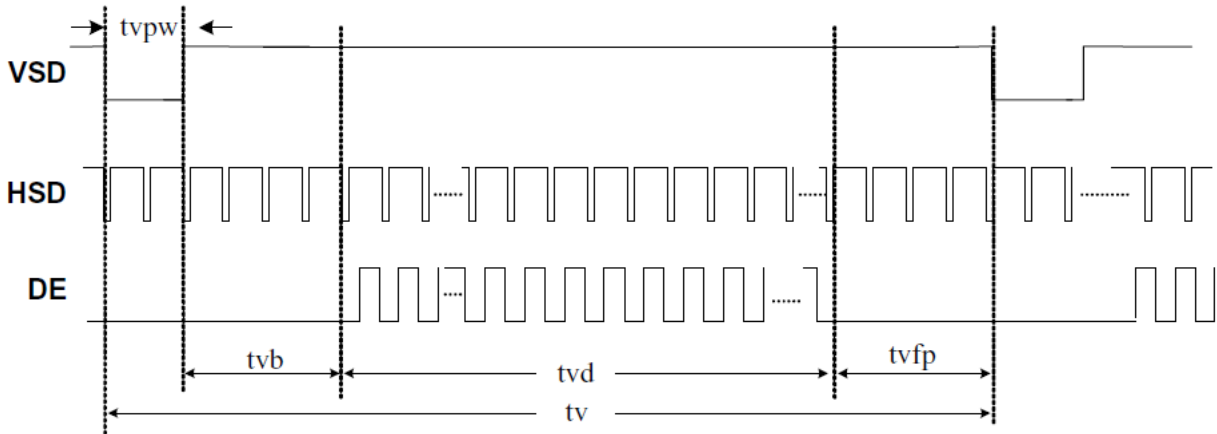

Vertical timing

7.4 Power On / Off Sequence

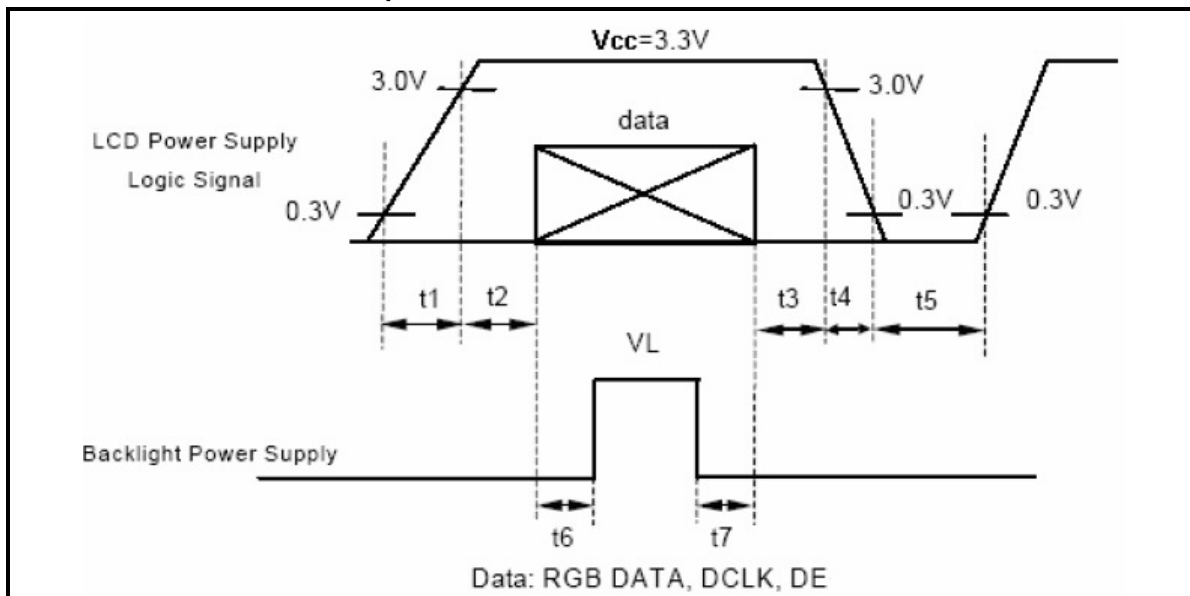

$t1 \leq 10\text{ms} : 1 \text{ sec} \leq t5$
 $50\text{ms} \leq t2 : 200\text{ms} \leq t6$
 $0 < t3 \leq 50\text{ms} : 200\text{ms} \leq t7$
 $0 < t4 \leq 10\text{ms}$

8. OPTICAL CHARACTERISTICS

Item	Symbol	Condition	Min.	Typ.	Max.	Unit
Brightness	--	Note1, Note 3, ($\theta = 0^\circ$, Normal Viewing Angle)	400	500	--	cd/m ²
Uniformity	B-uni		70	75	-	%
Contrast Ratio	CR		480	600	--	--
Response Time	Tr		--	6	--	ms
	Tf		--	14	--	ms
Color Chromaticity	White	Wx	0.260	0.310	0.360	--
		Wy	0.280	0.330	0.380	--
View angle	Horizontal	$\theta x+$	65	75	--	
		$\theta x-$	65	75	--	
	Vertical	$\theta Y+$	50	60	--	
		$\theta Y-$	60	70	--	
Image sticking	tis	2 hours	--	--	2	Sec

Note : The following optical specifications shall be measured in a darkroom or equivalent state (ambient luminance ≤ 1 lux, and at room temperature). The operation temperature is $25^\circ\text{C} \pm 2^\circ\text{C}$. The measurement method is shown in Note1.

Note1: The method of optical measurement:

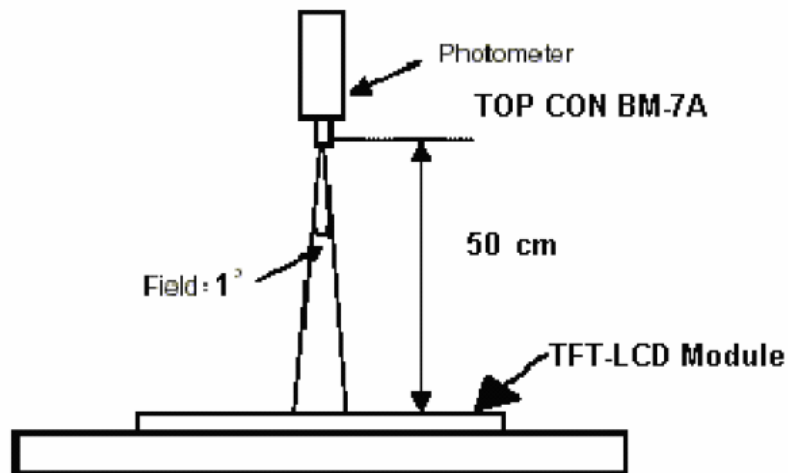

Note2: Measured at the center area of the panel and at the viewing angle of the $\theta x = \theta y = 0^\circ$

Note3: Definition of Contrast Ratio (CR):

CR = Luminance with all pixels in white state \div Luminance with all pixels in Black state

Note4: Definition of Viewing Angle:

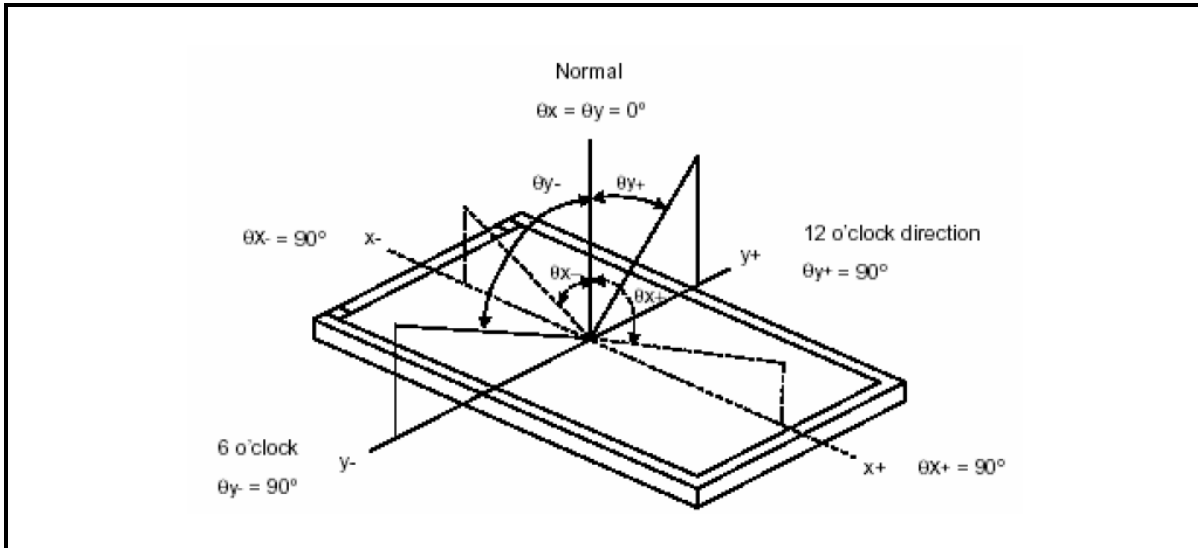

Note 5: Definition of Brightness Uniformity (B-uni):

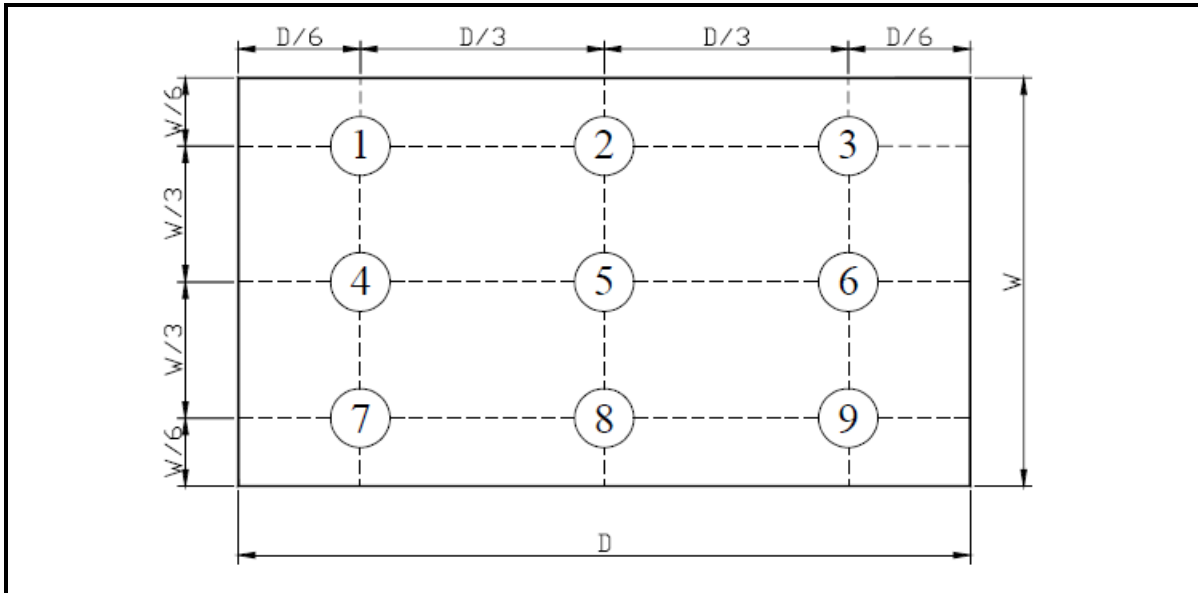

B-uni = (Minimum luminance of 9 points ÷ Maximum luminance of 9 points) X 100%

Note 6: Definition of Response Time:

The Response Time is set initially by defining the “Rising Time (Tr)” and the “Falling Time (Tf)” respectively. Tr and Tf are defined as following figure

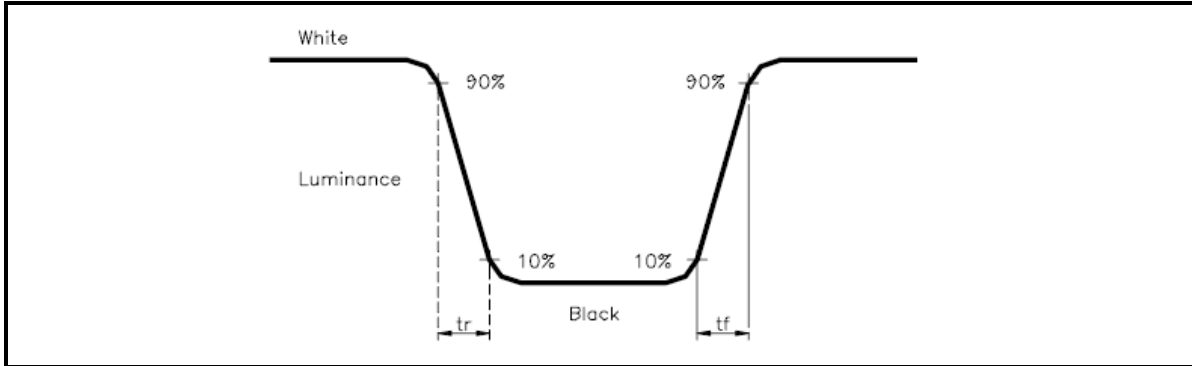

Note 7: Definition of Chromaticity:

The color coordinates (Wx, Wy), (Rx, Ry), (Gx, Gy), and (Bx, By) are obtained with all pixels in the viewing field at white, red, green, and blue states, respectively.

Note 8: Definition of Image sticking (tis):

Continuously display the test pattern shown in the figure below for 2 hours. Then display a completely white screen. The previous image shall not persist more than 2 sec at 25 °C

Image sticking pattern

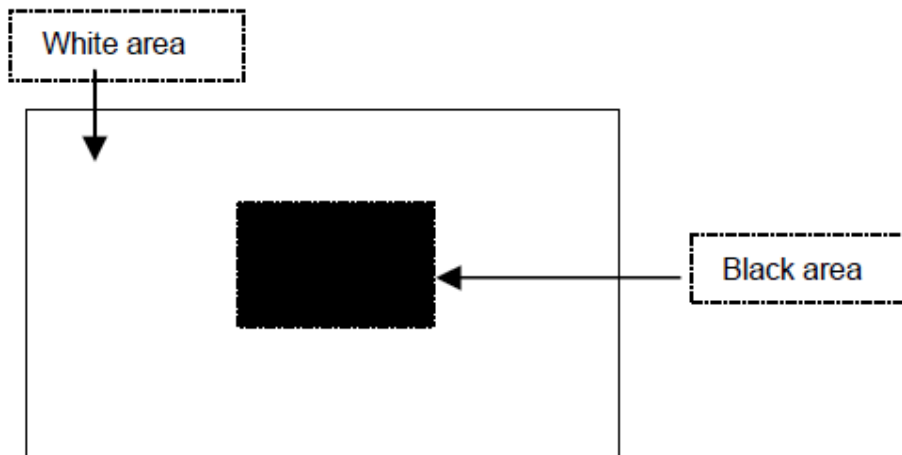

9. RELIABILITY

9.1 Test Condition

9.1.1 Temperature and Humidity(Ambient Temperature)

Temperature : $25 \pm 5^{\circ}\text{C}$

Humidity : $65 \pm 5\%$

9.1.2 Operation

Unless specified otherwise, test will be conducted under function state.

9.1.3 Container

Unless specified otherwise, vibration test will be conducted to the product itself without putting it in a container.

9.1.4 Test Frequency

In case of related to deterioration such as shock test. It will be conducted only once.

9.2 TESTS

No.	ITEM	CONDITION CRITERION
1	High Temperature Storage	80°C, 120 hrs
2	Low Temperature Storage	-30°C, 120 hrs
3	High Temperature Operating	70°C, 120 hrs
4	Low Temperature Operating	-20°C, 120 hrs
5	High Temperature/Humidity Non-Operating	60°C, 90%RH, 120 hrs
6	Temperature Shock Non-Operating	-30°C \longleftrightarrow 80°C (0.5hr each), 25 cycles
7	Vibration Test Non-Operating	Frequency:0 ~ 55 Hz Amplitude:1.5 mm Sweep Time:11min Test Period:6 Cycles for each Direction of X,Y,Z
8	Electro-static Discharge Non-Operating	150pF,330Ω Air:± 8KV;Contact: ±4KV 10 times/point;4 points/panel face

Note1: The test sample have recovery time for 24 hours at room temperature before the function check. In the standard conditions, there is no any touch panel function NG issue occurred.

9.3 JUDGMENT STANDARD

The judgment of the above test should be made as follow:

Pass: Normal display image with no obvious non-uniformity and no line defect. Partial transformation of the module parts should be ignored.

Fail: No display image, obvious non-uniformity, or line defects.

9.4 INCOMING INSPECTION STANDARDS

No.	Parameter	Criteria																
1	Operating	Display function: No Display malfunction (Major)																
		Contrast ratio (Black, White): Does not meet specified range in the spec. (Major) (Note:3)																
		Line Defect: No obvious Vertical and Horizontal line defect in bright, dark and colored. (Major) (Note:1)																
		Point Defect (Red, green, blue, dark): Active area ≤ 5 dots (Minor) (Note:1)																
		<table border="1"> <thead> <tr> <th rowspan="2">Item</th> <th colspan="2">Acceptable number</th> <th rowspan="2">Total</th> </tr> <tr> <th>A</th> <th>B</th> </tr> </thead> <tbody> <tr> <td>Bright</td> <td>0</td> <td>2</td> <td rowspan="3">5</td> </tr> <tr> <td>Dark</td> <td>2</td> <td>4</td> </tr> <tr> <td>Total</td> <td>2</td> <td>4</td> </tr> </tbody> </table>	Item	Acceptable number		Total	A	B	Bright	0	2	5	Dark	2	4	Total	2	4
Item	Acceptable number			Total														
	A	B																
Bright	0	2	5															
Dark	2	4																
Total	2	4																
		Non-uniformity: Visible through 6%ND filter. (Minor)																
		Foreign material in Black or White spots shape ($W > 1/4L$)																
		<table border="1"> <thead> <tr> <th>Zone Dimension</th> <th>Acceptable number</th> <th>Class Of Defects</th> <th>AQL Level</th> </tr> </thead> <tbody> <tr> <td>$D > 0.5$</td> <td>0</td> <td rowspan="3">Minor</td> <td rowspan="3">1.5</td> </tr> <tr> <td>$0.1 \leq D \leq 0.5$</td> <td>4</td> </tr> <tr> <td>$D \leq 0.1$</td> <td>*</td> </tr> </tbody> </table> <p>D = (Long + Short) / 2 * : Disregard</p>	Zone Dimension	Acceptable number	Class Of Defects	AQL Level	$D > 0.5$	0	Minor	1.5	$0.1 \leq D \leq 0.5$	4	$D \leq 0.1$	*				
Zone Dimension	Acceptable number	Class Of Defects	AQL Level															
$D > 0.5$	0	Minor	1.5															
$0.1 \leq D \leq 0.5$	4																	
$D \leq 0.1$	*																	
		Foreign Material in Line or spiral shape ($W \leq 1/4L$) (Note: 4)																
		<table border="1"> <thead> <tr> <th>L (mm) \ Zone W(mm)</th> <th>Acceptable number</th> <th>Class Of Defects</th> <th>AQL Level</th> </tr> </thead> <tbody> <tr> <td>$L > 2$ $W > 0.1$</td> <td>0</td> <td rowspan="3">Minor</td> <td rowspan="3">1.5</td> </tr> <tr> <td>$0.5 < L \leq 2$ $0.03 < W \leq 0.1$</td> <td>1</td> </tr> <tr> <td>$L \leq 0.5$ $W \leq 0.03$</td> <td>*</td> </tr> </tbody> </table> <p>L : Length W : Width * : Disregard</p>	L (mm) \ Zone W(mm)	Acceptable number	Class Of Defects	AQL Level	$L > 2$ $W > 0.1$	0	Minor	1.5	$0.5 < L \leq 2$ $0.03 < W \leq 0.1$	1	$L \leq 0.5$ $W \leq 0.03$	*				
L (mm) \ Zone W(mm)	Acceptable number	Class Of Defects	AQL Level															
$L > 2$ $W > 0.1$	0	Minor	1.5															
$0.5 < L \leq 2$ $0.03 < W \leq 0.1$	1																	
$L \leq 0.5$ $W \leq 0.03$	*																	
2	External Inspection (non-operating)	Dimension: Outline (Major)																
		Bezel appearance: uneven (Minor)																
		Scratch on the polarize: (Note:2)																
		<table border="1"> <thead> <tr> <th>L (mm) \ Zone W(mm)</th> <th>Acceptable number</th> <th>Class Of Defects</th> <th>AQL Level</th> </tr> </thead> <tbody> <tr> <td>-- $W > 0.1$</td> <td>0</td> <td rowspan="2">Minor</td> <td rowspan="2">1.5</td> </tr> <tr> <td>$L \leq 2$ $W \leq 0.1$</td> <td>3</td> </tr> </tbody> </table> <p>L : Length W : Width * : Disregard</p>	L (mm) \ Zone W(mm)	Acceptable number	Class Of Defects	AQL Level	-- $W > 0.1$	0	Minor	1.5	$L \leq 2$ $W \leq 0.1$	3						
L (mm) \ Zone W(mm)	Acceptable number	Class Of Defects	AQL Level															
-- $W > 0.1$	0	Minor	1.5															
$L \leq 2$ $W \leq 0.1$	3																	
		Dent or bubble on the polarize (Note:2)																
		<table border="1"> <thead> <tr> <th>Zone Dimension</th> <th>Acceptable number</th> <th>Class Of Defects</th> <th>AQL Level</th> </tr> </thead> <tbody> <tr> <td>$D \leq 0.05$</td> <td>*</td> <td rowspan="2">Minor</td> <td rowspan="2">1.5</td> </tr> <tr> <td>$D \leq 0.3$</td> <td>3</td> </tr> </tbody> </table> <p>D = (Long + Short) / 2 * : Disregard</p>	Zone Dimension	Acceptable number	Class Of Defects	AQL Level	$D \leq 0.05$	*	Minor	1.5	$D \leq 0.3$	3						
Zone Dimension	Acceptable number	Class Of Defects	AQL Level															
$D \leq 0.05$	*	Minor	1.5															
$D \leq 0.3$	3																	

Class of defects			Definition
	Major	AQL 0.65%	It is a defect that is likely to result in failure or to reduce materially the usability of the product for the intended function.
Minor	AQL 1.5%	It is a defect that will not result in functioning problem with deviation classified.	

Note1:

(a) Bright point defect is defined as point defect of R,G,B with area $>1/2$ pixel respectively

(b) Dark point defect is defined as visible in full white pattern.

(c) Definition of distribution of point defect is as follows:

- minimum separation between dark point defects should be larger than 5mm.
- minimum separation between bright point defects should be larger than 5mm.

(d) Definition of joined bright point defect and joined dark point defect are as follows:

- Two or more joined bright point defects must be nil.
- Three joined dark point defects must be nil.
- Coupling of one dark and one bright point in junction is counted as one dark and bright spot with 1 pair maximum.
- Two Joined dark point is counted as two dark points with 2 pair maximum.

Note2: The external inspection should be conducted at the distance 30 ± 5 cm between the eyes of inspector and the panel.

Note3: Luminance measurement for contrast ratio is at the distance 50 ± 5 cm between the detective head and the panel with ambient luminance less than 1 lux. Contrast ratio is obtained at optimum view angle.

Note4: W-Width in mm , L-length of Max.(L1,L2) in mm.

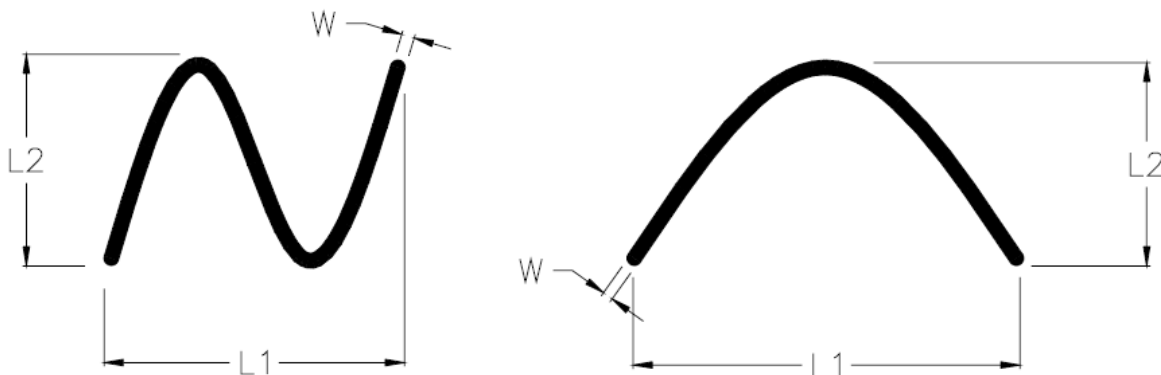

9.5 Sampling Condition

Unless otherwise agree in written, the sampling inspection shall be applied to the incoming inspection of customer.

Lot size: Quantity of shipment lot per model.

Sampling type: normal inspection, single sampling

Sampling table: MIL-STD-105E

Inspection level: Level II

9.6 Inspection conditions

The LCD shall be inspected under 40W white fluorescent light.

$\theta \leq 45^\circ$ inspection under non-operating condition.

$\theta \leq 5^\circ$ inspection under operating condition

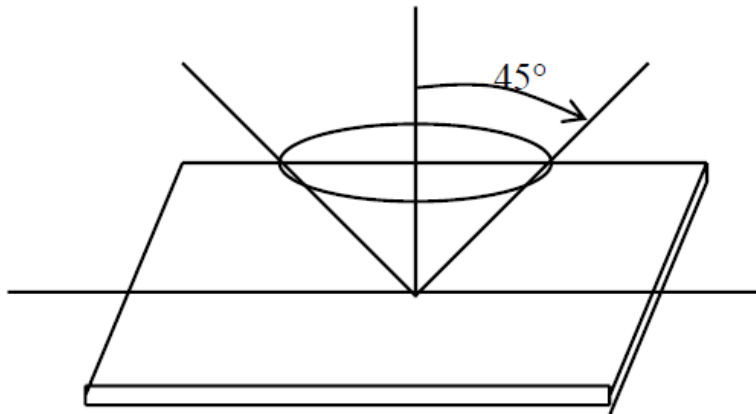

Definition of applicable Zones

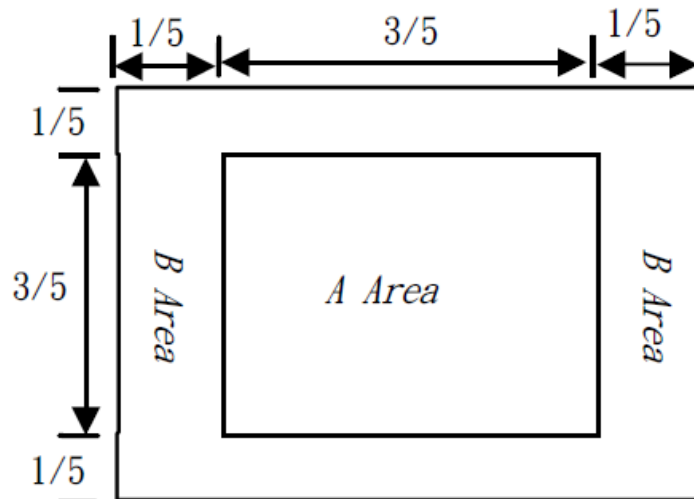

10. PRECAUTION RELATING PRODUCT HANDLING

10.1 SAFETY

- 10.1.1** If the LCD panel breaks , be careful not to get the liquid crystal to touch your skin.
- 10.1.2** If the liquid crystal touches your skin or clothes , please wash it off immediately by using soap and water.

10.2 HANDLING

- 10.2.1** Avoid any strong mechanical shock which can break the glass.
- 10.2.2** Avoid static electricity which can damage the CMOS LSI—When working with the module, be sure to ground your body and any electrical equipment you may be using.
- 10.2.3** Do not remove the panel or frame from the module.
- 10.2.4** The polarizing plate of the display is very fragile. So , please handle it very carefully, Do not touch, push or rub the exposed polarizing with anything harder than an HB pencil lead (glass , tweezers , etc.)
- 10.2.5** Do not wipe the polarizing plate with a dry cloth, as it may easily scratch the surface of plate.
- 10.2.6** Do not touch the display area with bare hands , this will stain the display area.
- 10.2.7** Do not use ketonics solvent & aromatic solvent. Use with a soft cloth soaked with a cleaning naphtha solvent.
- 10.2.8** To control temperature and time of soldering is $280 \pm 10^{\circ}\text{C}$ and 3-5 sec.
- 10.2.9** To avoid liquid (include organic solvent) stained on LCM.

10.3 STORAGE

- 10.3.1** Store the panel or module in a dark place where the temperature is $25^{\circ}\text{C} \pm 5^{\circ}\text{C}$ and the humidity is below 65% RH.
- 10.3.2** Do not place the module near organics solvents or corrosive gases.
- 10.3.3** Do not crush, shake, or jolt the module.