



Your Total LCD Solution Provider

<http://www.orientdisplay.com>

**SPECIFICATION
FOR
LCD MODULE**

MODULE NO: AFD1024768A0L-8.0N4WTH

VERSION NO: 02

Customer's Approval:

--

	SIGNATURE	DATE
PREPARED BY (RD ENGINEER)		
CHECKED BY		
APPROVED BY		

REVISION STATUS

Version	Revised Date	Page	Content	Modified by
V1.0	2013/03/13	--	First Issued	Garry
V2.0	2013/08/31	--	Update company logo	Garry

TABLE OF CONTENTS

No.	Content	Page
	PRODUCT SPECIFICATION	1
	REVISION STATUS.....	2
	TABLE OF CONTENTS	3
1.	GENERAL DESCRIPTION.....	4
2.	MECHANICAL SPECIFICATION	5
3.	PIN DESCRIPTION	6
4.	ABSOLUTE MAXIMUM RATINGS	8
5.	BLOCK DIAGRAM	9
6.	RELATIONSHIP BETWEEN DISPLAYED COLOR AND INPUT	10
7.	ELECTRICAL CHARACTERISTICS	11
8.	OPTICAL CHARACTERISTICS	15
9.	RELIABILITY.....	18
10.	PRECAUTION RELATING PRODUCT HANDLING	23

1. GENERAL DESCRIPTION

1.1 Description

The specifications is model AFD1024768A0L-8.0N4WTH is a color active matrix thin film transistor (TFT) liquid crystal display (LCD) that uses amorphous silicon TFT as a switching device. This model is composed of a TFT LCD panel, a driving circuit, a back light system. This TFT LCD has a 8.0 (4:3) inch diagonally measured active display area with XGA (1024 horizontal by 768 vertical pixel) resolution.

1.2 Features:

No.	Item	Specification	Unit
1	Panel Size	8.0"	Inch
2	Number of Pixels	1024 (W) x RGB x 768 (H)	Pixels
3	Active Area	162.048 (W) × 121.536 (H)	mm
4	Pixel Pitch	0.15825 (W) x 0.15825(H)	mm
5	Outline Dimension	183 (W) × 141 (H) × 6.3 (T)	mm
6	Number of Colors	262K	- -
7	Display Mode	TN / Normally White / Transmissive	- -
8	View Direction	4:30 o'clock(Gray Inversion)	- -
9	Display Format	RGB vertical stripe	- -
10	Surface Treatment	Clear	- -
11	Contrast Ratio	700 (Typ.)	- -
12	Luminance (cd/m ²)	1000 (Typ.)	cd/m ²
13	Interface	LVDS 6 bit Interface	- -
14	Backlight	White LED	- -
15	Operation Temperature	-20 ~ 70	°C
16	Storage Temperature	-30 ~ 80	°C
17	Weight	(TBD)	g

2. MECHANICAL SPECIFICATION

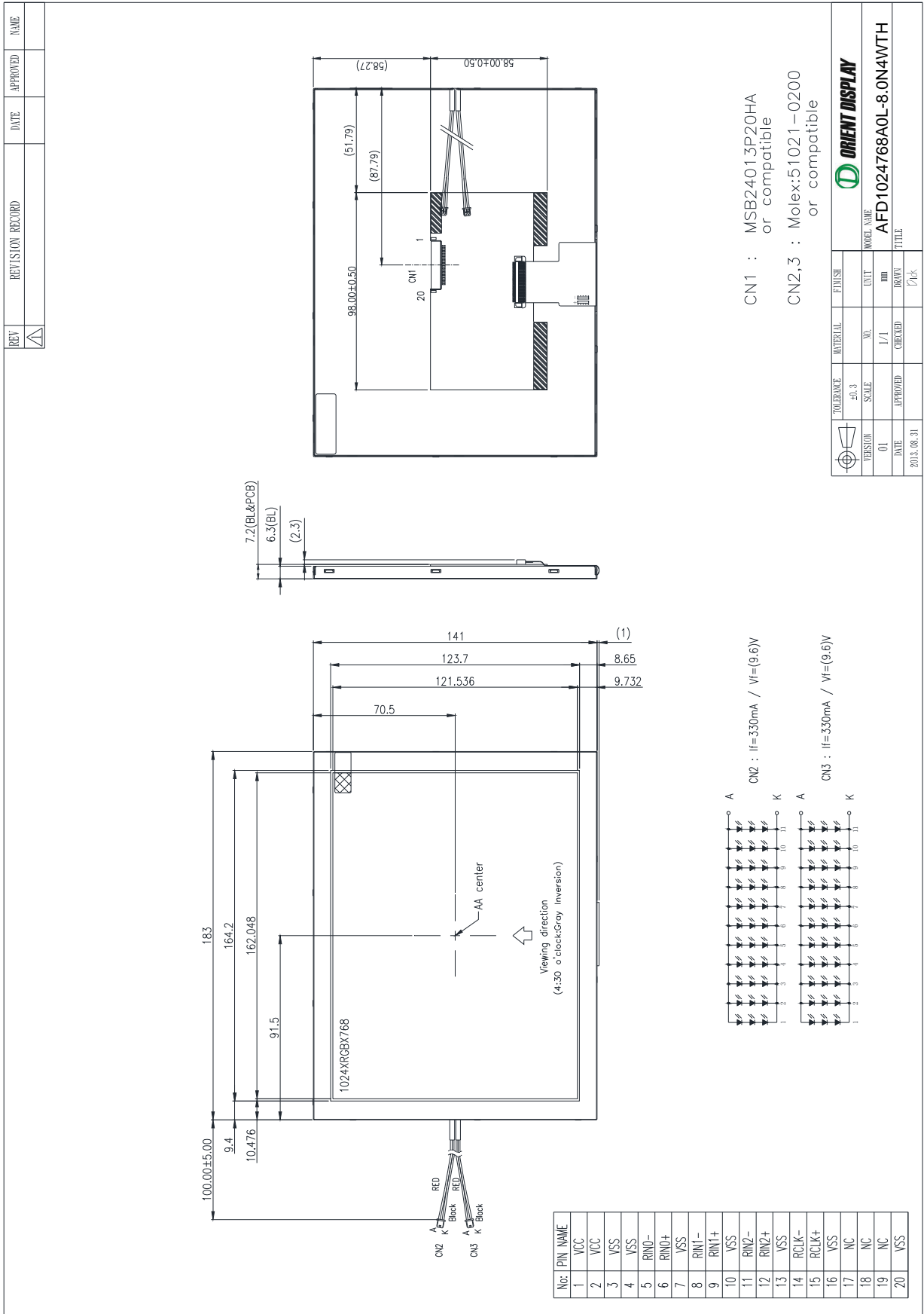

3. PIN DESCRIPTION

3.1 TFT LCD Module(CN1)

Pin No.	Symbol	I/O	Function	Remark
1	VCC	P	Power Supply +3.3V	
2	VCC	P	Power Supply +3.3V	
3	GND	P	Ground	
4	GND	P	Ground	
5	RXIN0-	I	Negative LVDS differential data input	
6	RXIN0+	I	Positive LVDS differential data input	
7	GND	P	Ground	
8	RXIN1-	I	Negative LVDS differential data input	
9	RXIN1+	I	Positive LVDS differential data input	
10	GND	P	Ground	
11	RXIN2-	I	Negative LVDS differential data input	
12	RXIN2+	I	Positive LVDS differential data input	
13	GND	P	Ground	
14	CLK-	I	Negative LVDS differential clock input	
15	CLK+	I	Positive LVDS differential clock input	
16	GND	P	Ground	
17	NC	-	NO Connect	
18	NC	-	NO Connect	
19	NC	-	NO Connect	
20	GND	P	Ground	

NOTE:

1. NC Pin must be floating

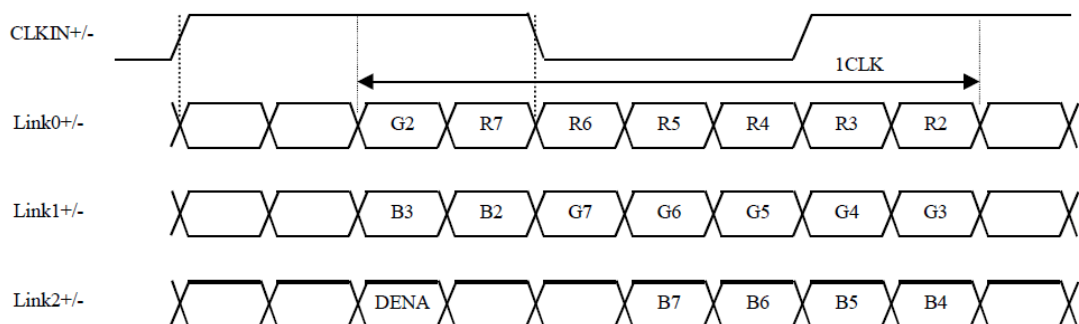

3.2 Backlight Unit(CN2,CN3)

Pin No.	Symbol	Function	Remark
1	LEDA	Power Supply for LED backlight	RED
2	LEDK	GND for LED backlight	BLACK

4. ABSOLUTE MAXIMUM RATINGS

4.1 Electrical Absolute Rating

4.1.1 TFT LCD Module

Item	Symbol	Values		Unit	Note
		Min	Max.		
Power supply voltage	VCC	-0.3	5.0	V	

4.1.2 Environment Absolute Rating

Item	Symbol	Values			Unit	Note
		Min	Typ	Max.		
Operating Temperature	Topa	-20		70	°C	Ambient temperature
Storage Temperature	Tstg	-30		80	°C	

5. BLOCK DIAGRAM

5.1 TFT LCD Module

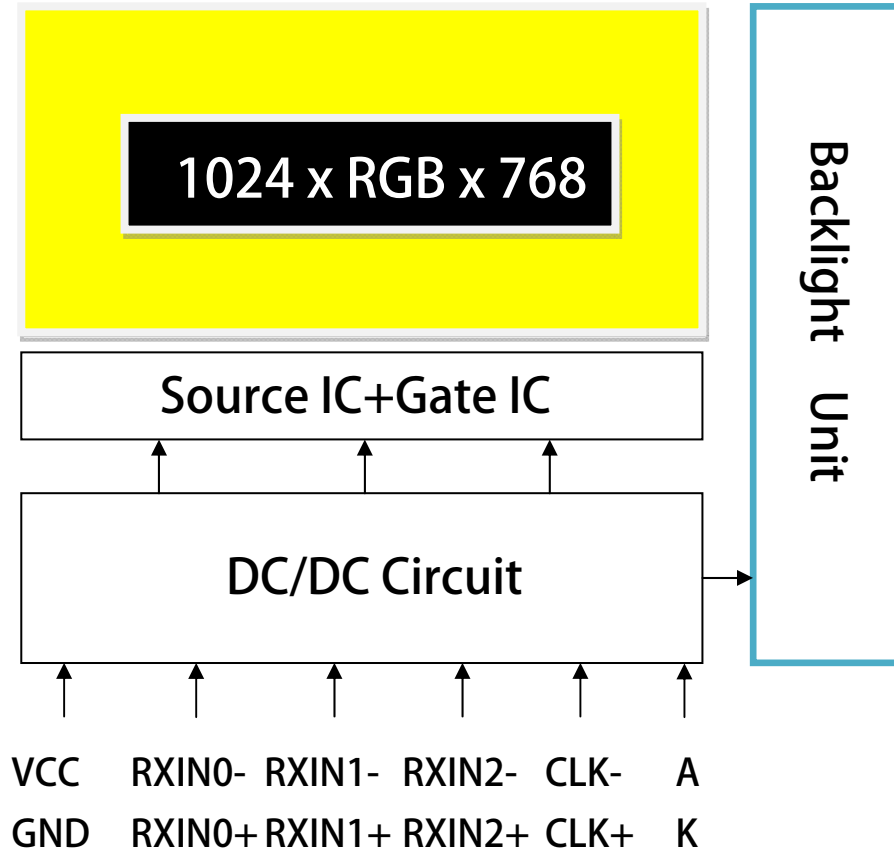

6. Relationship Between Displayed Color and Input

6.1 6 bit

	Color & Gray Scale	Data Signal																	
		R5	R4	R3	R2	R1	R0	G5	G4	G3	G2	G1	G0	B5	B4	B3	B2	B1	B0
Basic Color	Black	0	0	0	0	0	0	0	0	0	0	0	0	0	0	0	0	0	0
	Red	1	1	1	1	1	1	0	0	0	0	0	0	0	0	0	0	0	0
	Green	0	0	0	0	0	0	1	1	1	1	1	1	0	0	0	0	0	0
	Blue	0	0	0	0	0	0	0	0	0	0	0	0	1	1	1	1	1	1
	Cyan	0	0	0	0	0	0	1	1	1	1	1	1	1	1	1	1	1	1
	Magenta	1	1	1	1	1	1	0	0	0	0	0	0	1	1	1	1	1	1
	Yellow	1	1	1	1	1	1	1	1	1	1	1	1	0	0	0	0	0	0
	White	1	1	1	1	1	1	1	1	1	1	1	1	1	1	1	1	1	1
Red	Black	0	0	0	0	0	0	0	0	0	0	0	0	0	0	0	0	0	0
	Red(1)	0	0	0	0	0	1	0	0	0	0	0	0	0	0	0	0	0	0
	Red(2)	0	0	0	0	1	0	0	0	0	0	0	0	0	0	0	0	0	0
	:	:	:	:	:	:	:	:	:	:	:	:	:	:	:	:	:	:	:
	Red(31)	0	1	1	1	1	1	0	0	0	0	0	0	0	0	0	0	0	0
	:	:	:	:	:	:	:	:	:	:	:	:	:	:	:	:	:	:	:
	Red(62)	1	1	1	1	1	0	0	0	0	0	0	0	0	0	0	0	0	0
Red(63)	1	1	1	1	1	1	0	0	0	0	0	0	0	0	0	0	0	0	
Green	Black	0	0	0	0	0	0	0	0	0	0	0	0	0	0	0	0	0	0
	Green(1)	0	0	0	0	0	0	0	0	0	0	0	1	0	0	0	0	0	0
	Green(2)	0	0	0	0	0	0	0	0	0	0	1	0	0	0	0	0	0	0
	:	:	:	:	:	:	:	:	:	:	:	:	:	:	:	:	:	:	:
	Green(31)	0	0	0	0	0	0	0	1	1	1	1	0	0	0	0	0	0	0
	:	:	:	:	:	:	:	:	:	:	:	:	:	:	:	:	:	:	:
	Green(62)	0	0	0	0	0	0	1	1	1	1	1	0	0	0	0	0	0	0
Green(63)	0	0	0	0	0	0	1	1	1	1	1	1	0	0	0	0	0	0	
Blue	Black	0	0	0	0	0	0	0	0	0	0	0	0	0	0	0	0	0	0
	Blue(1)	0	0	0	0	0	0	0	0	0	0	0	0	0	0	0	0	0	1
	Blue(2)	0	0	0	0	0	0	0	0	0	0	0	0	0	0	0	0	1	0
	:	:	:	:	:	:	:	:	:	:	:	:	:	:	:	:	:	:	:
	Blue(31)	0	0	0	0	0	0	0	0	0	0	0	0	0	1	1	1	1	1
	:	:	:	:	:	:	:	:	:	:	:	:	:	:	:	:	:	:	:
	Blue(62)	0	0	0	0	0	0	0	0	0	0	0	0	1	1	1	1	1	0
Blue(63)	0	0	0	0	0	0	0	0	0	0	0	0	1	1	1	1	1	1	

0 : Low level voltage, 1 :High level voltage

Each basic color can be displayed in 64 gray scales from 6 bit data signals. With the combination of total 18 bit data signals, the 262K-color display can be achieved on the screen.

7. ELECTRICAL CHARACTERISTICS

7.1 TFT LCD Module

Item	Symbol	Min.	Typ.	Max.	Unit	Note
Power supply	VCC	3.0	3.3	3.6	V	
Input Voltage for logic	Differential Input High Threshold	VTH		+100	mV	
	Differential Input Low Threshold	VTL	-100		mV	
Magnitude differential Input Voltage	[V _{id}]	200	-	600	mV	Note 2
Input voltage range (singled-end)	RxVIN	0	-	2.4	V	Note 2
Differential input common mode voltage	RxVcm	VID / 2	-	2.4 - VID / 2	V	Note 2
Differential input leakage current	RVxliz	-10	-	+10	uA	
Power Supply current	ICC	-	(150)	(250)	mA	Note 1

Note 1: frame =60Hz , Ta=25°C , Display pattern : Black pattern

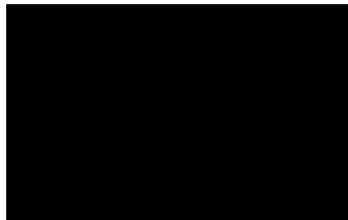

Note 2:

Single-end Signals

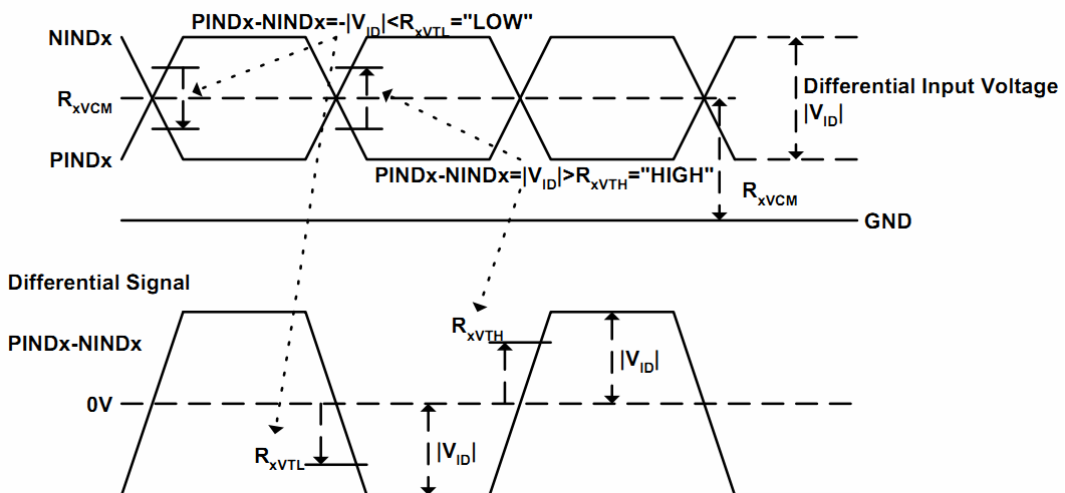

7.2 Backlight Unit(CN2,CN3)

Item	Symbol	Value			Unit	Condition
		Min.	Typ.	Max.		
LED Voltage	VL	(9.0)	(9.6)	(10.5)	V	
LED Current	IF	-	330	-	mA	3S11P
Power Consumption	PBL	-	3.168	-	W	
LED Life Time (25°C)	-	(40000)	-	-	hr	(1)

Note (1): The “LED life time” is defined as the module brightness decrease to 50% original brightness that the ambient temperature is 25°C 60% RH.

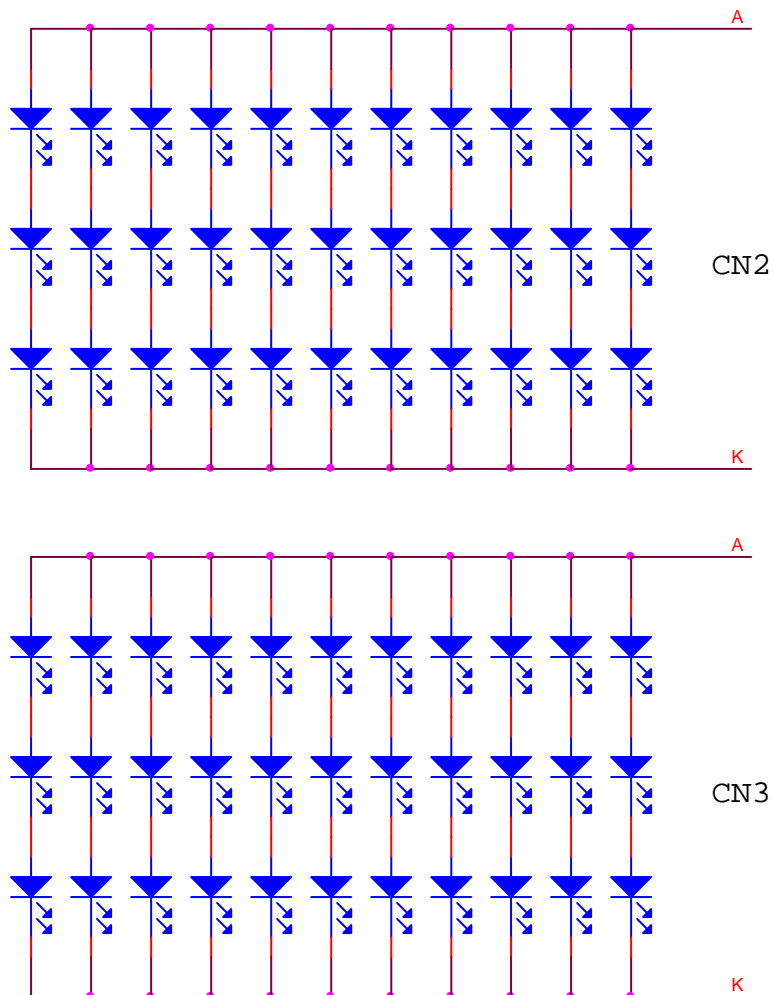

7.3 INTERFACE SPECIFICATIONS

7.3.1 AC Electrical Characteristics

Parameter	Symbol	Min.	Typ.	Max	Unit.	Note
Clock frequency	RxFCLK	20	-	71	MHz	
Input data skew margin	TRSKM	500	-	-	ps	
Clock high time	TLVCH	-	$4/(7 \cdot RxFCLK)$	-	ns	
Clock low time	TLVCL	-	$3/(7 \cdot RxFCLK)$	-	ns	

7.3.2 Input Clock and Data Timing Diagram

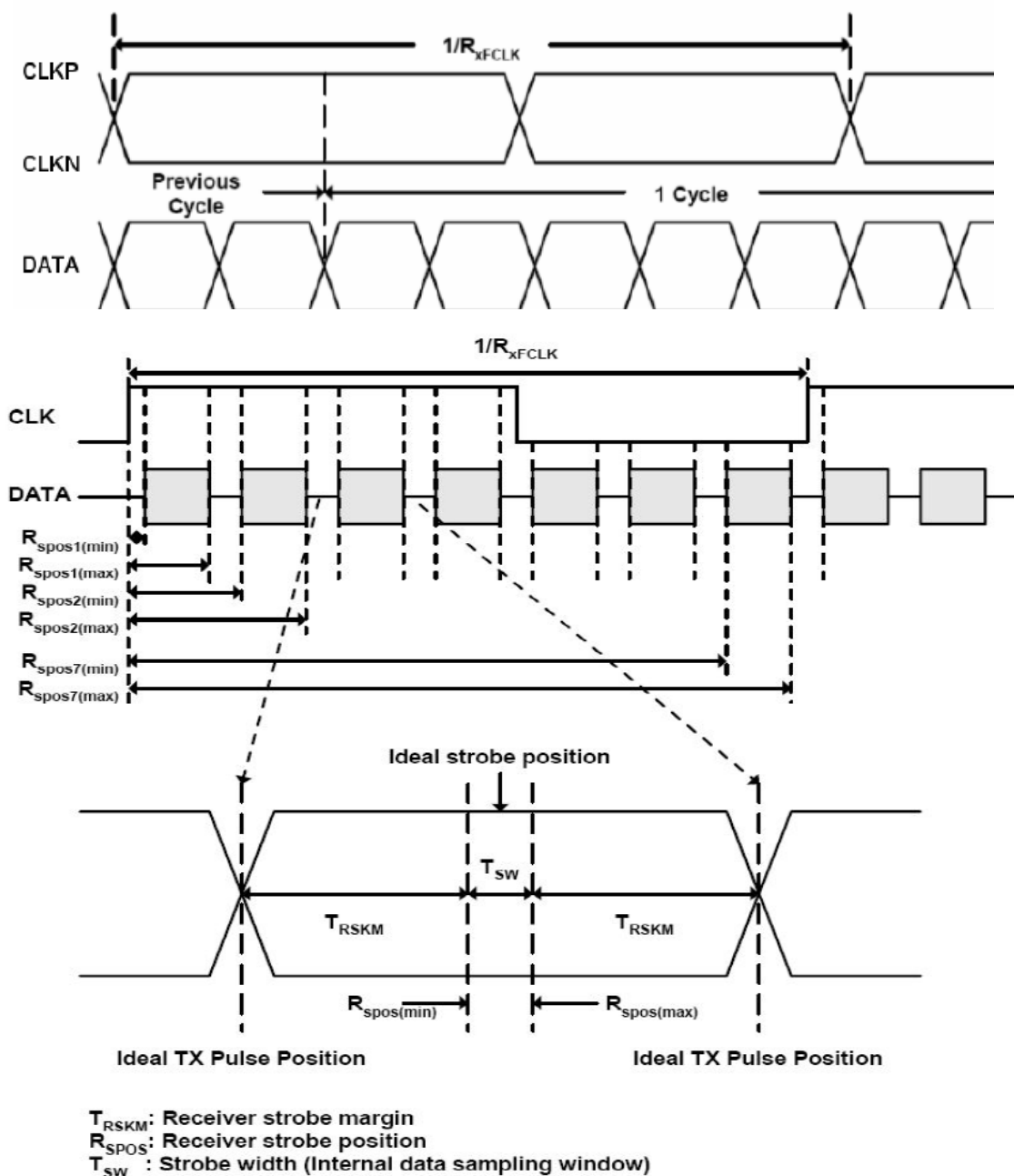

7.3.3 Timing

Signal	Parameter	Symbol	Min.	Typ.	Max.	Unit.	Remark
DCLK	CLK frequency	Fclk	52	65	71	MHz	
HSYNC	Horizontal Line	Th	1114	1344	1400	CLK	
	HS Display Area	Thd	-	1024	-	CLK	
	HS Blanking	Thb+thfp	90	320	376	CLK	
VSYNC	VS Period Time	Tv	778	806	845	th	
	VS Display Area	Tvd	-	768	-	th	
	VS Blanking	Tvb+Tvfp	10	38	77	th	

7.4 Power On / Off Sequence

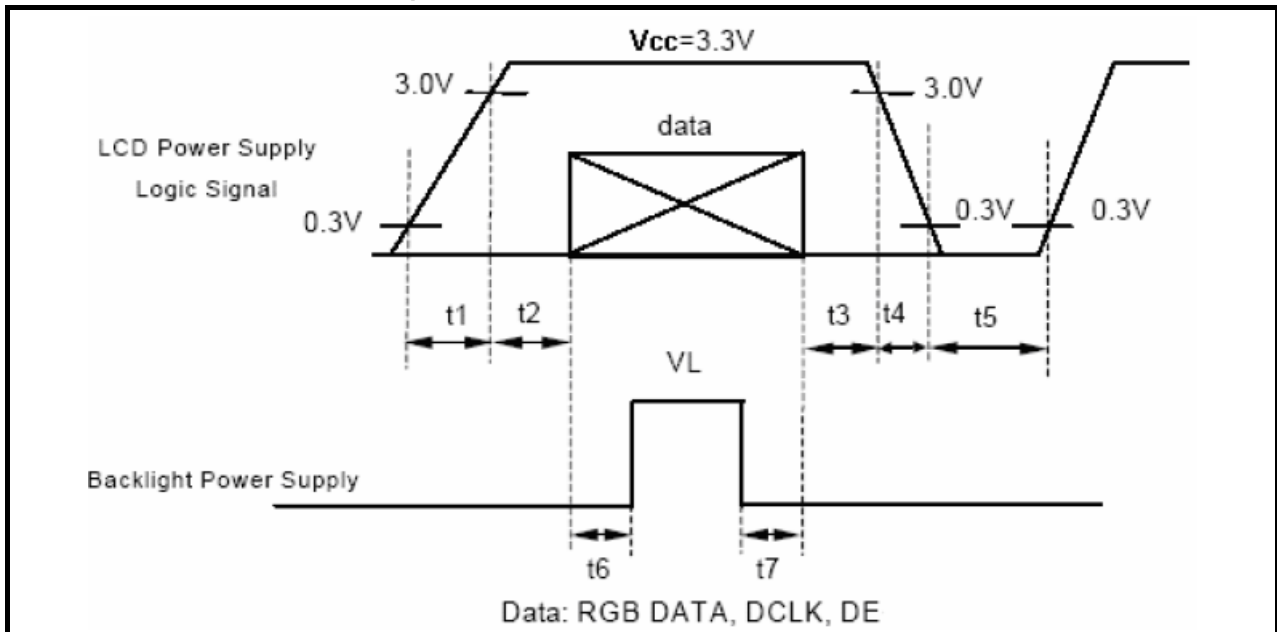

$t1 \leq 10\text{ms} : 1 \text{ sec} \leq t5$
 $50\text{ms} \leq t2 : 200\text{ms} \leq t6$
 $0 < t3 \leq 50\text{ms} : 200\text{ms} \leq t7$
 $0 < t4 \leq 10\text{ms}$

8. OPTICAL CHARACTERISTICS

Item		Symbol	Condition	Min.	Typ.	Max.	Unit
Brightness		--	Note1, Note 3, ($\theta = 0^\circ$; Normal Viewing Angle)	800	1000	--	cd/m ²
Uniformity		B-uni		70	75	-	%
Contrast Ratio		CR		400	500	--	--
Response Time		Tr		--	10	20	ms
		Tf		--	20	30	ms
Color Chromaticity	White	Wx	Center CR \geq 10	0.260	0.310	0.360	--
		Wy		0.280	0.330	0.380	--
View angle	Horizontal	θ_{x+}		65	75	--	
		θ_{x-}		65	75	--	
	Vertical	θ_{Y+}	65	75	--		
		θ_{Y-}	65	75	--		
Image sticking		tis	2 hours	--	--	2	Sec

Note : The following optical specifications shall be measured in a darkroom or equivalent state (ambient luminance ≤ 1 lux, and at room temperature). The operation temperature is $25^\circ\text{C} \pm 2^\circ\text{C}$. The measurement method is shown in Note1.

Note1: The method of optical measurement:

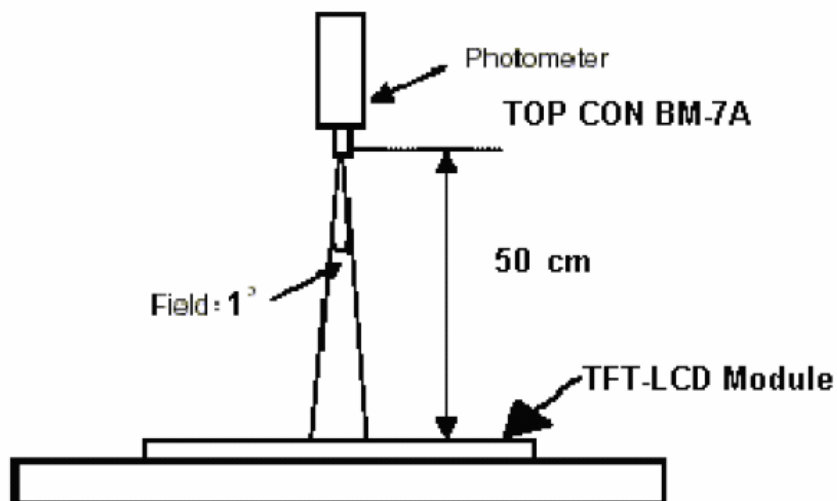

Note2: Measured at the center area of the panel and at the viewing angle of the $\theta_x = \theta_y = 0^\circ$

Note3: Definition of Contrast Ratio (CR):

CR = Luminance with all pixels in white state \div Luminance with all pixels in Black state

Note4: Definition of Viewing Angle:

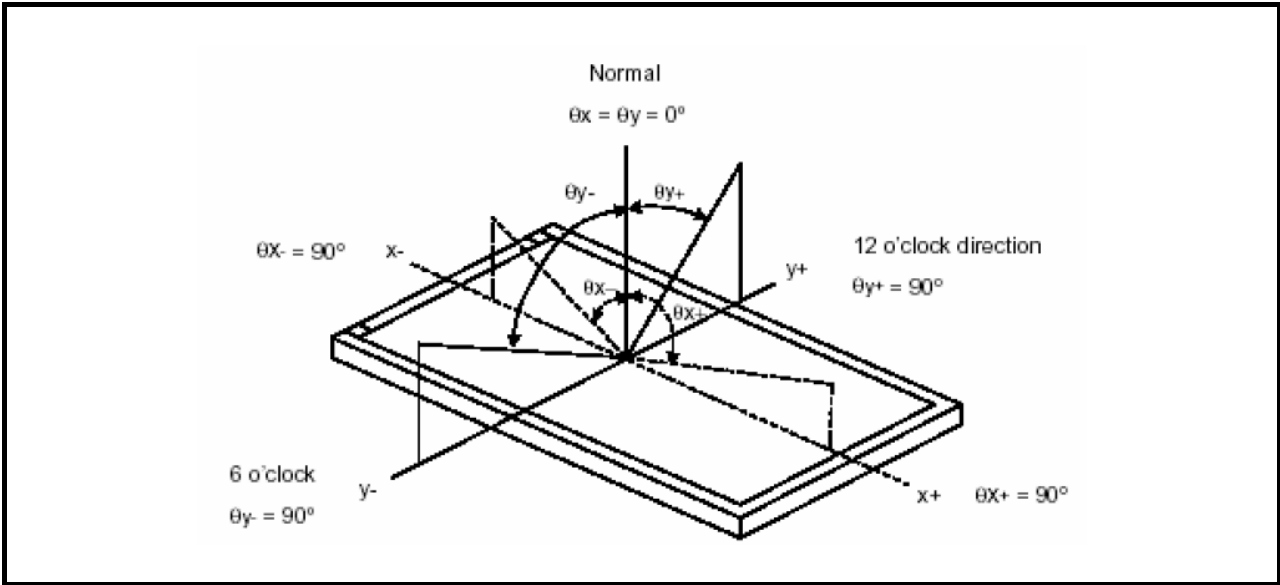

Note 5: Definition of Brightness Uniformity (B-uni):

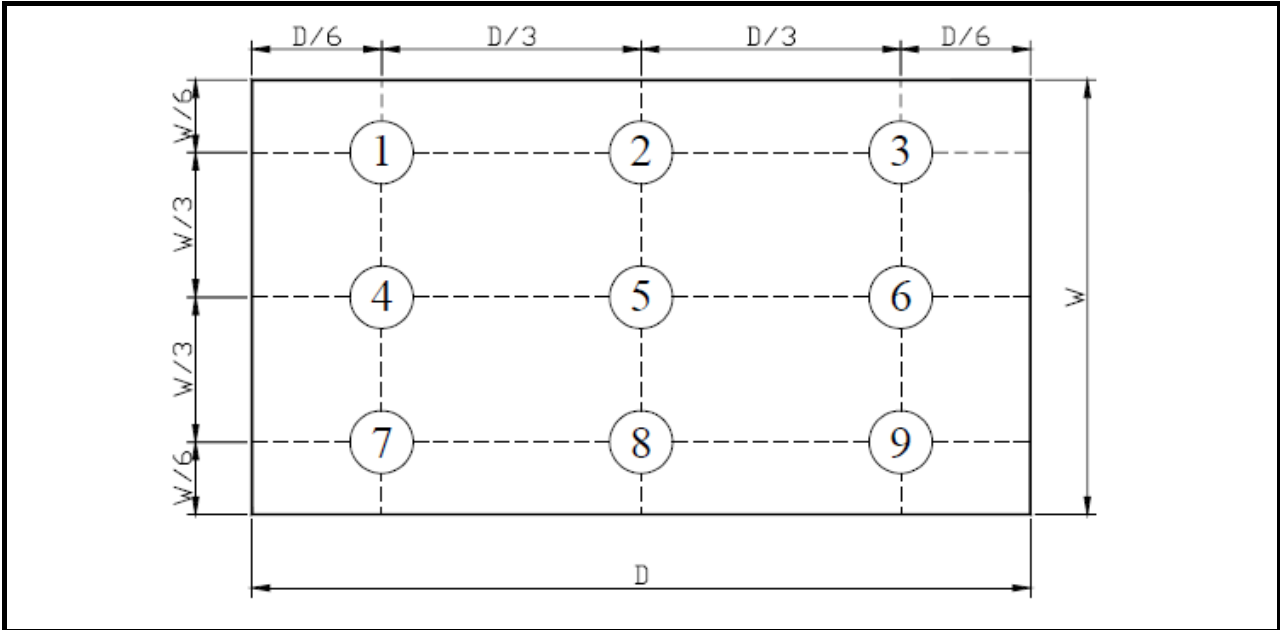

$$B\text{-uni} = (\text{Minimum luminance of 9 points} \div \text{Maximum luminance of 9 points}) \times 100\%$$

Note6: Definition of Response Time:

The Response Time is set initially by defining the “Rising Time (Tr)” and the “Falling Time (Tf)” respectively. Tr and Tf are defined as following figure

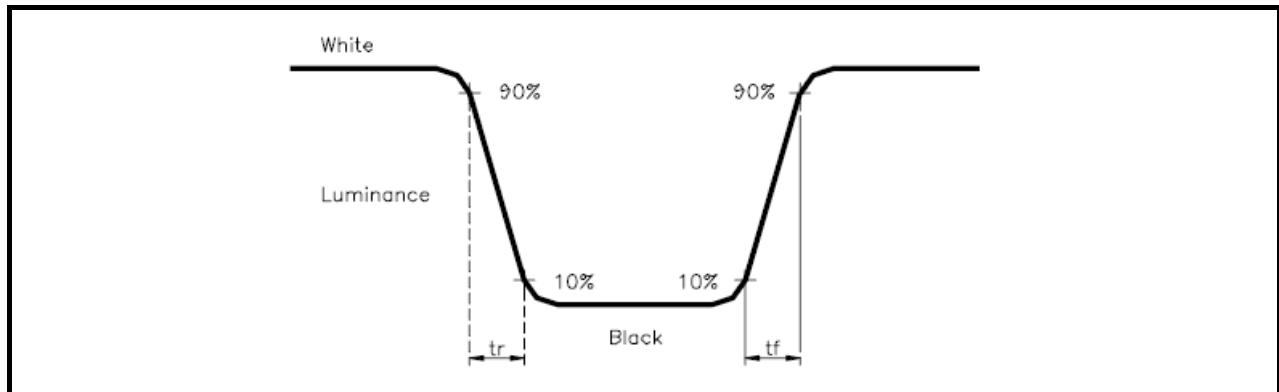

Note 7: Definition of Chromaticity:

The color coordinates (Wx,Wy),(Rx,Ry),(Gx,Gy),and (Bx,By) are obtained with all pixels in the viewing field at white, red, green, and blue states, respectively.

Note 8: Definition of Image sticking (tis):

Continuously display the test pattern shown in the figure below for 2 hours. Then display a completely white screen. The previous image shall not persist more than 2 sec at 25 °C

Image sticking pattern

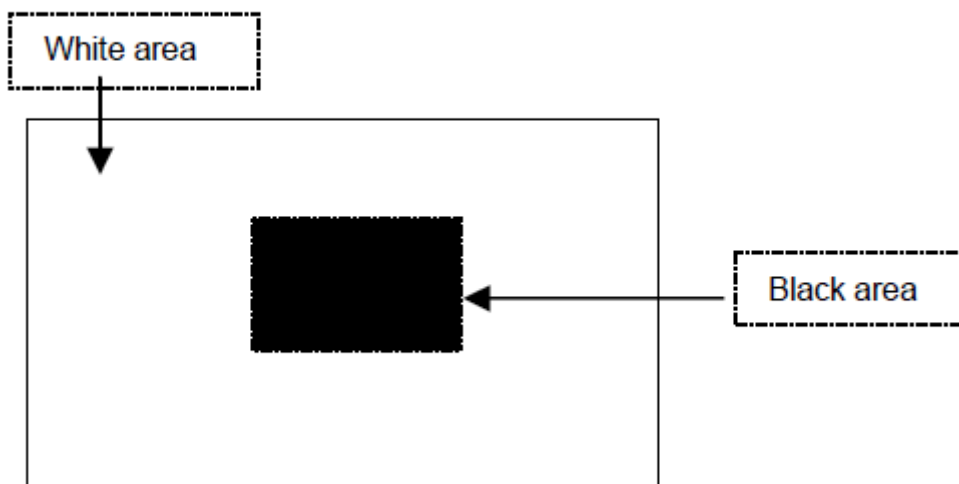

9. RELIABILITY

9.1 Test Condition

9.1.1 Temperature and Humidity(Ambient Temperature)

Temperature : $25 \pm 5^{\circ}\text{C}$

Humidity : $65 \pm 5\%$

9.1.2 Operation

Unless specified otherwise, test will be conducted under function state.

9.1.3 Container

Unless specified otherwise, vibration test will be conducted to the product itself without putting it in a container.

9.1.4 Test Frequency

In case of related to deterioration such as shock test. It will be conducted only once.

9.2 TESTS

No.	ITEM	CONDITION CRITERION
1	High Temperature Storage	80°C, 120 hrs
2	Low Temperature Storage	-30°C, 120 hrs
3	High Temperature Operating	70°C, 120 hrs
4	Low Temperature Operating	-20°C, 120 hrs
5	High Temperature/Humidity Non-Operating	40°C, 90%RH, 120 hrs
6	Temperature Shock Non-Operating	-10°C \longleftrightarrow 60°C (0.5hr each), 25 cycles
7	Vibration Test Non-Operating	Frequency:0 ~ 55 Hz Amplitude:1.5 mm Sweep Time:11min Test Period:6 Cycles for each Direction of X,Y,Z
8	Electro-static Discharge Non-Operating	150pF, 330Ω Air:± 8KV;Contact: ±4KV 10 times/point;4 points/panel face

9.3 JUDGEMENT STANDARD

The judgement of the above test should be made as follows:

Pass: Normal display image with no obvious non-uniformity and no line defect. Partial transformation of the module parts should be ignored.

Fail: No display image, obvious non-uniformity, or line defects.

9.4 INCOMING INSPECTION STANDARDS

No.	Parameter	Criteria														
1	Operating	Display function: No Display malfunction (Major)														
		Contrast ratio (Black, White): Does not meet specified range in the spec. (Major) (Note:3)														
		Line Defect: No obvious Vertical and Horizontal line defect in bright, dark and colored. (Major) (Note:1)														
		Point Defect (Red, green, blue, dark): Active area ≤ 5 dots (Minor) (Note:1)														
		<table border="1"> <thead> <tr> <th rowspan="2">Item</th> <th colspan="2">Acceptable number</th> <th rowspan="2">Total</th> </tr> <tr> <th>A</th> <th>B</th> </tr> </thead> <tbody> <tr> <td>Bright</td> <td>0</td> <td>2</td> <td rowspan="3">5</td> </tr> <tr> <td>Dark</td> <td>2</td> <td>4</td> </tr> <tr> <td>Total</td> <td>2</td> <td>4</td> </tr> </tbody> </table>	Item	Acceptable number		Total	A	B	Bright	0	2	5	Dark	2	4	Total
Item	Acceptable number			Total												
	A	B														
Bright	0	2	5													
Dark	2	4														
Total	2	4														
1	Operating	Non-uniformity: Visible through 6%ND filter. (Minor)														
		Foreign material in Black or White spots shape ($W > 1/4L$)														
		<table border="1"> <thead> <tr> <th>Zone Dimension</th> <th>Acceptable number</th> <th>Class Of Defects</th> <th>AQL Level</th> </tr> </thead> <tbody> <tr> <td>$D > 0.5$</td> <td>0</td> <td rowspan="3">Minor</td> <td rowspan="3">1.5</td> </tr> <tr> <td>$0.1 \leq D \leq 0.5$</td> <td>4</td> </tr> <tr> <td>$D \leq 0.1$</td> <td>*</td> </tr> </tbody> </table>	Zone Dimension	Acceptable number	Class Of Defects	AQL Level	$D > 0.5$	0	Minor	1.5	$0.1 \leq D \leq 0.5$	4	$D \leq 0.1$	*		
		Zone Dimension	Acceptable number	Class Of Defects	AQL Level											
		$D > 0.5$	0	Minor	1.5											
$0.1 \leq D \leq 0.5$	4															
$D \leq 0.1$	*															
$D = (\text{Long} + \text{Short}) / 2$ * : Disregard																
Foreign Material in Line or spiral shape ($W \leq 1/4L$) (Note: 4)																
1	Operating	<table border="1"> <thead> <tr> <th>L (mm) \ Zone W(mm)</th> <th>Acceptable number</th> <th>Class Of Defects</th> <th>AQL Level</th> </tr> </thead> <tbody> <tr> <td>$L > 2$ $W > 0.1$</td> <td>0</td> <td rowspan="3">Minor</td> <td rowspan="3">1.5</td> </tr> <tr> <td>$0.5 < L \leq 2$ $0.03 < W \leq 0.1$</td> <td>1</td> </tr> <tr> <td>$L \leq 0.5$ $W \leq 0.03$</td> <td>*</td> </tr> </tbody> </table>	L (mm) \ Zone W(mm)	Acceptable number	Class Of Defects	AQL Level	$L > 2$ $W > 0.1$	0	Minor	1.5	$0.5 < L \leq 2$ $0.03 < W \leq 0.1$	1	$L \leq 0.5$ $W \leq 0.03$	*		
		L (mm) \ Zone W(mm)	Acceptable number	Class Of Defects	AQL Level											
		$L > 2$ $W > 0.1$	0	Minor	1.5											
		$0.5 < L \leq 2$ $0.03 < W \leq 0.1$	1													
		$L \leq 0.5$ $W \leq 0.03$	*													
L : Length W : Width * : Disregard																
2	External Inspection (non-operating)	Dimension: Outline (Major)														
		Bezel appearance: uneven (Minor)														
		Scratch on the polarize: (Note:2)														
		<table border="1"> <thead> <tr> <th>L (mm) \ Zone W(mm)</th> <th>Acceptable number</th> <th>Class Of Defects</th> <th>AQL Level</th> </tr> </thead> <tbody> <tr> <td>-- $W > 0.1$</td> <td>0</td> <td rowspan="2">Minor</td> <td rowspan="2">1.5</td> </tr> <tr> <td>$L \leq 2$ $W \leq 0.1$</td> <td>3</td> </tr> </tbody> </table>	L (mm) \ Zone W(mm)	Acceptable number	Class Of Defects	AQL Level	-- $W > 0.1$	0	Minor	1.5	$L \leq 2$ $W \leq 0.1$	3				
		L (mm) \ Zone W(mm)	Acceptable number	Class Of Defects	AQL Level											
-- $W > 0.1$	0	Minor	1.5													
$L \leq 2$ $W \leq 0.1$	3															
L : Length W : Width * : Disregard																
Dent or bubble on the polarize (Note:2)																
2	External Inspection (non-operating)	<table border="1"> <thead> <tr> <th>Zone Dimension</th> <th>Acceptable number</th> <th>Class Of Defects</th> <th>AQL Level</th> </tr> </thead> <tbody> <tr> <td>$D \leq 0.05$</td> <td>*</td> <td rowspan="2">Minor</td> <td rowspan="2">1.5</td> </tr> <tr> <td>$D \leq 0.3$</td> <td>3</td> </tr> </tbody> </table>	Zone Dimension	Acceptable number	Class Of Defects	AQL Level	$D \leq 0.05$	*	Minor	1.5	$D \leq 0.3$	3				
		Zone Dimension	Acceptable number	Class Of Defects	AQL Level											
		$D \leq 0.05$	*	Minor	1.5											
		$D \leq 0.3$	3													
		$D = (\text{Long} + \text{Short}) / 2$ * : Disregard														

Class of defects			Definition
	Major	AQL 0.65%	It is a defect that is likely to result in failure or to reduce materially the usability of the product for the intended function.
Minor	AQL 1.5%	It is a defect that will not result in functioning problem with deviation classified.	

Note1:

(a) Bright point defect is defined as point defect of R,G,B with area $> 1/2$ pixel respectively

(b) Dark point defect is defined as visible in full white pattern.

(c) Definition of distribution of point defect is as follows:

- minimum separation between dark point defects should be larger than 5mm.
- minimum separation between bright point defects should be larger than 5mm.

(d) Definition of joined bright point defect and joined dark point defect are as follows:

- Two or more joined bright point defects must be nil.
- Three joined dark point defects must be nil.
- Coupling of one dark and one bright point in junction is counted as one dark and bright spot with 1 pair maximum.
- Two Joined dark point is counted as two dark points with 2 pair maximum.

Note2: The external inspection should be conducted at the distance 30 ± 5 cm between the eyes of inspector and the panel.

Note3: Luminance measurement for contrast ratio is at the distance 50 ± 5 cm between the detective head and the panel with ambient luminance less than 1 lux. Contrast ratio is obtained at optimum view angle.

Note4: W-Width in mm , L-length of Max.(L1,L2) in mm.

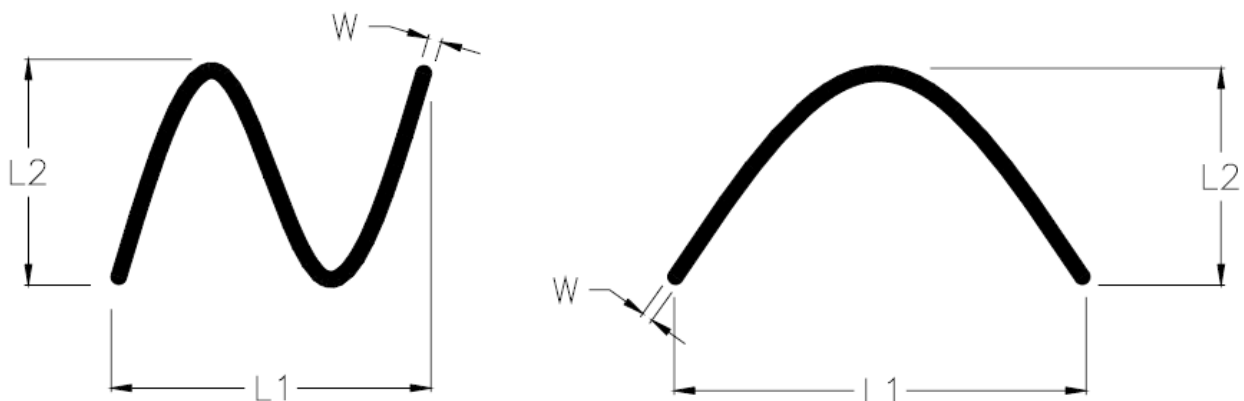

9.5 Sampling Condition

Unless otherwise agree in written, the sampling inspection shall be applied to the incoming inspection of customer.

Lot size: Quantity of shipment lot per model.

Sampling type: normal inspection, single sampling

Sampling table: MIL-STD-105E

Inspection level: Level II

9.6 Inspection conditions

The LCD shall be inspected under 40W white fluorescent light.

$\theta \leq 45^\circ$ inspection under non-operating condition.

$\theta \leq 5^\circ$ inspection under operating condition

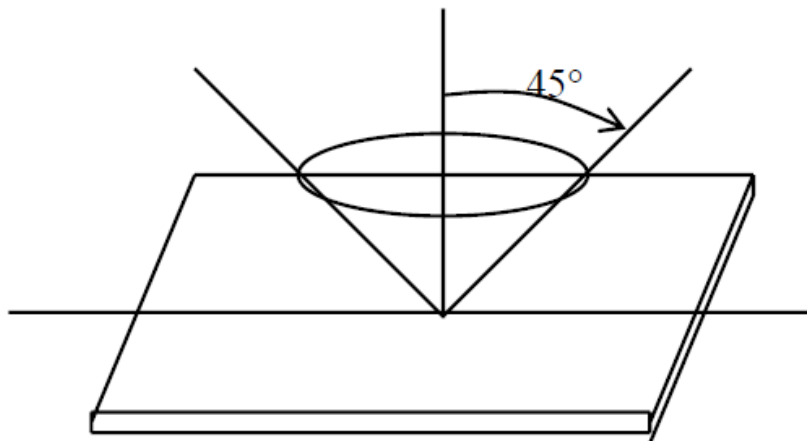

Definition of applicable Zones

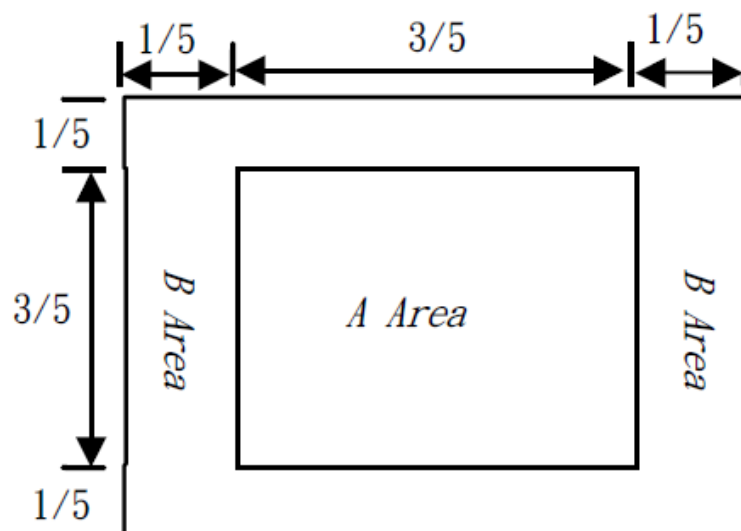

10. PRECAUTION RELATING PRODUCT HANDLING

10.1 SAFETY

10.1.1 If the LCD panel breaks , be careful not to get the liquid crystal to touch your skin.

10.1.2 If the liquid crystal touches your skin or clothes , please wash it off immediately by using soap and water.

10.2 HANDLING

10.2.1 Avoid any strong mechanical shock which can break the glass.

10.2.2 Avoid static electricity which can damage the CMOS LSI—When working with the module, be sure to ground your body and any electrical equipment you may be using.

10.2.3 Do not remove the panel or frame from the module.

10.2.4 The polarizing plate of the display is very fragile. So , please handle it very carefully, Do not touch, push or rub the exposed polarizing with anything harder than an HB pencil lead (glass , tweezers , etc.)

10.2.5 Do not wipe the polarizing plate with a dry cloth, as it may easily scratch the surface of plate.

10.2.6 Do not touch the display area with bare hands , this will stain the display area.

10.2.7 Do not use ketonics solvent & aromatic solvent. Use with a soft cloth soaked with a cleaning naphtha solvent.

10.2.8 To control temperature and time of soldering is $280 \pm 10^{\circ}\text{C}$ and 3-5 sec.

10.2.9 To avoid liquid (include organic solvent) stained on LCM.

10.3 STORAGE

10.3.1 Store the panel or module in a dark place where the temperature is $25^{\circ}\text{C} \pm 5^{\circ}\text{C}$ and the humidity is below 65% RH.

10.3.2 Do not place the module near organics solvents or corrosive gases.

10.3.3 Do not crush, shake, or jolt the module.