



## DESCRIPTION

A6120 is a series of low power consumption, low dropout voltage regulator with a typical dropout voltage of 1.0V at 2A load current.

A6120 can provide output value in the range of 1.2V~5.0V in 0.1V steps. It also can customized on command.

Other than every voltage version can be used as an adjustable voltage version, with which desired voltage can be achieved by setting the values of two external resistors of the application circuitry.

A6120 has well load transient response and good temperature characteristic, And it uses trimming technique to guarantee output voltage accuracy within±2%.

The A6120 is available in SOT-223 and TO-252 Packages.

## ORDERING INFORMATION

Package Type	Part Number	
SOT-223 SPQ: 2,500pcs/Reel	N	A6120NR-XX
		A6120NVR-XX
TO-252 SPQ: 2,500pcs/Reel	D	A6120DR-XX
		A6120DVR-XX
Note	X: Output Voltage 12=1.2V; 18=1.8V; 25=2.5V; 33=3.3V; 50=5.0V V: Halogen free Package R: Tape & Reel	
AiT provides all RoHS products		

## FEATURES

- Low Power Consumption:3.0uA (Typ.)
- Maximum output current : 2A
- Maximum input voltage: 18V
- Line regulation: 0.2% (Typical)
- Output Voltage Range:1.2V~5.0V (customized on command in 0.1V steps)
- Highly Accurate:±2%(±1% customized)
- Typical Dropout Voltage:  
850mV@1.5A ( $V_{OUT}=3.3V$ )
- Operation environment Temperature:  
-40°C~85°C
- Available in SOT-223 and TO-252 Packages

## APPLICATION

- Battery Charger
- Battery Powered equipment
- Post Regulators for Switching Supplies
- Reference Voltage Source Regulation after Switching Power

## TYPICAL APPLICATION

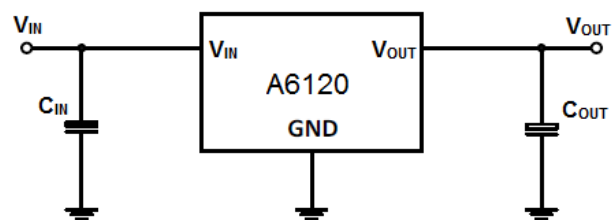
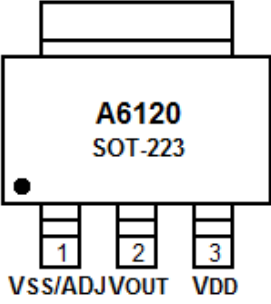
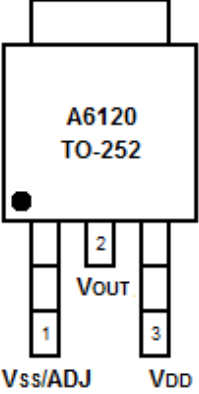

Fig1. A6120 fixed voltage application circuit

NOTE: Input capacitor ( $C_{IN}=1\mu F$ ) and Output capacitor ( $C_{OUT}=1\mu F$ ) are recommended in all application circuit. ceramic capacitor is recommended.



## PIN DESCRIPTION

 <p style="text-align: center;">Top View</p>	 <p style="text-align: center;">Top View</p>	
Pin #	Symbol	Function
1	V <sub>SS</sub> /ADJ	V <sub>SS</sub> /ADJ Pin
2	V <sub>OUT</sub>	Output Pin
3	V <sub>DD</sub>	Input Pin



## ABSOLUTE MAXIMUM RATINGS

Max Input Voltage		20V
T <sub>J</sub> , Operating Junction Temperature		125°C
T <sub>A</sub> , Ambient Temperature		-40°C~85°C
Package Thermal Resistance	SOT-223	20°C/W
	TO-252	12°C/W
T <sub>S</sub> , Storage Temperature		-40°C~150°C
Lead Temperature & Time		260°C, 10 Sec

Stress beyond above listed "Absolute Maximum Ratings" may lead permanent damage to the device. These are stress ratings only and operations of the device at these or any other conditions beyond those indicated in the operational sections of the specifications are not implied. Exposure to absolute maximum rating conditions for extended periods may affect device reliability.

## RECOMMENDED OPERATING CONDITIONS

Parameter	Value
Input Voltage Range	Max. 18V
Ambient Temperature	-40°C~85°C



## ELECTRICAL CHARACTERISTICS

Test Conditions:  $C_{IN}=1\mu F$ ,  $C_{OUT}=1\mu F$ ,  $T_A=25^\circ C$ , unless Otherwise Specified

Parameter	Symbol	Test Condition		Min.	Typ.	Max.	Unit
Input Voltage	$V_{DD}$			-	-	18	V
Output Voltage	$V_{OUT}$			$V_{OUT}$ $\times 0.98$	$V_{OUT}$	$V_{OUT}$ $\times 1.02$	V
Maximum Output Current	$I_{OUT (Max.)}$	$V_{IN}-V_{OUT}=1.9V$	$V_{OUT}<1.5V$	2	-	-	A
		$V_{IN}-V_{OUT}=1.5V$	$1.5V \leq V_{OUT} < 2.0V$				
		$V_{IN}-V_{OUT}=1V$	$V_{OUT} \geq 2.0V$				
Input-Output Voltage Differential NOTE3	Dropout Voltage	$I_{OUT} \leq 1.5A$	$V_{OUT} < 1.5V$	-	1600	1800	mV
			$1.5V \leq V_{OUT} < 2.0V$	-	1200	1400	
			$V_{OUT} \geq 2.0V$	-	850	950	
Line Regulation NOTE1	$\frac{\Delta V_{OUT}}{\Delta V_{IN} \times V_{OUT}}$	$I_{OUT}=10mA$ Set $V_{OUT}+1V \leq V_{IN} \leq 18V$		-	0.1	0.3	%/V
Load Regulation NOTE1,2	$\Delta V_{OUT}$	$1mA \leq I_{OUT} \leq 1.5A$	$V_{OUT} < 1.5V$	-	40	60	mV
			$1.5V \leq V_{OUT} < 2.0V$	-	20	40	
			$V_{OUT} \geq 2.0V$	-	10	30	
Quiescent Current	$I_q$	$V_{IN} = \text{Set } V_{OUT} + 1V$		-	3.0	5.0	$\mu A$
Output Voltage Temperature Coefficient	$\frac{\Delta V_{OUT}}{\Delta T \times V_{OUT}}$	$I_{OUT}=100mA$		-	200	-	ppm/ $^\circ C$
Thermal Resistance Junction to case	$\theta_{JC}$	SOT-223 TO-252		-	20 12	-	$^\circ C / W$

NOTE1: Line Regulation and Load Regulation in Table1 are tested under constant junction temperature.

NOTE2: When load current varies between 0~2A and  $V_{IN}-V_{OUT}$  ranges from 1V~18V at constant junction temperature, the parameter is satisfied the criterion in table.

NOTE3: Dropout Voltage is the voltage difference between the input and output pin when the input voltage is minimum to maintain the lowest spec output voltage.



## TYPICAL PERFORMANCE CHARACTERISTIC

1. Load Regulation ( $V_{OUT}=1.2V$ )

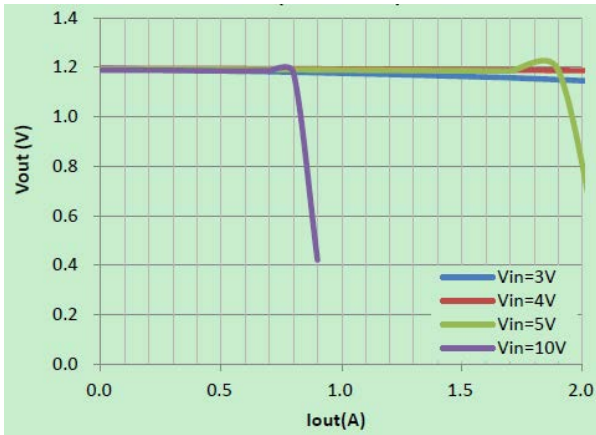

2. Load Regulation ( $V_{OUT}=3.3V$ )

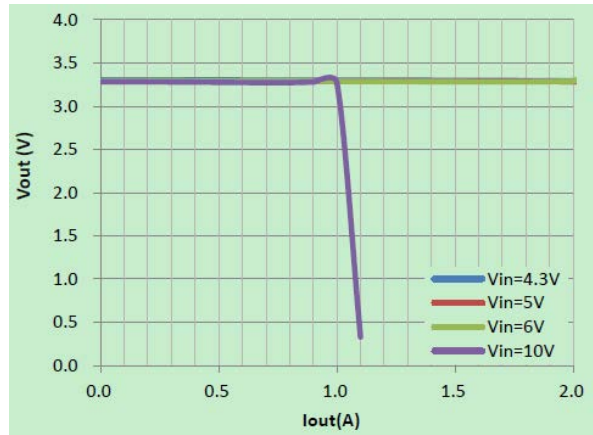

3. Load Regulation ( $V_{OUT}=5.0V$ )

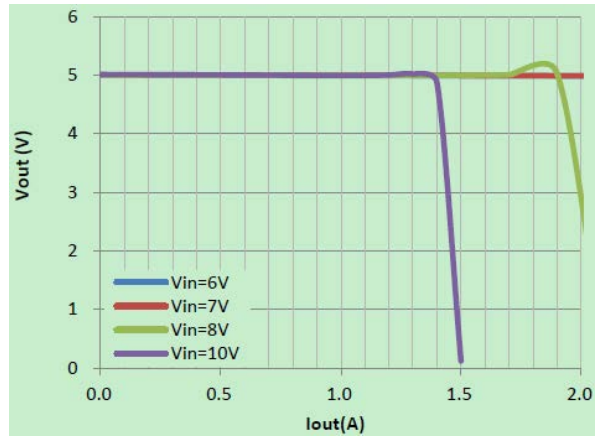

4. Line Regulation

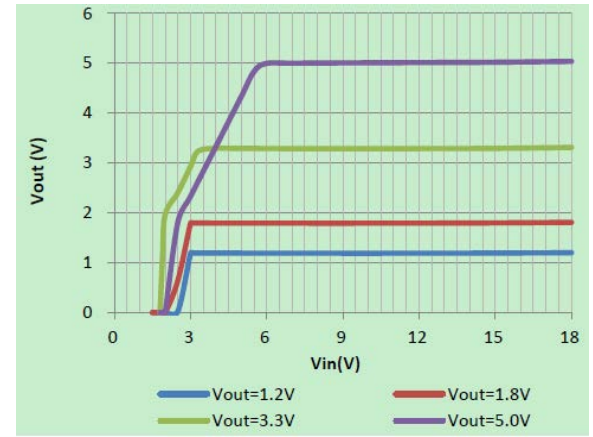

5. Dropout

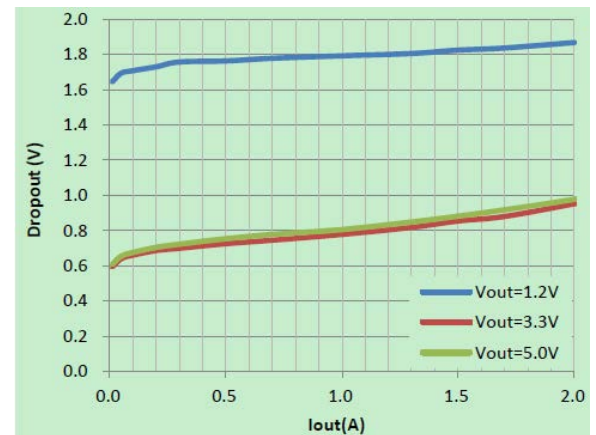

6.  $I_q$

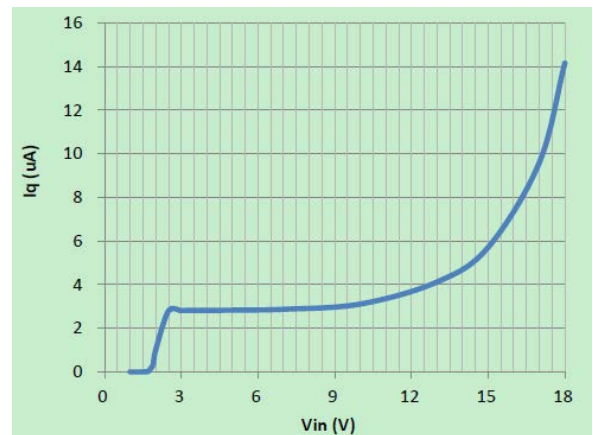



7. Line Transient Response

$I_{OUT}=100\text{mA}$ ,  $V_{IN}=3.3\text{V}$  to  $4.3\text{V}$

(Orange:  $V_{IN}$ , Green:  $V_{OUT}$ )

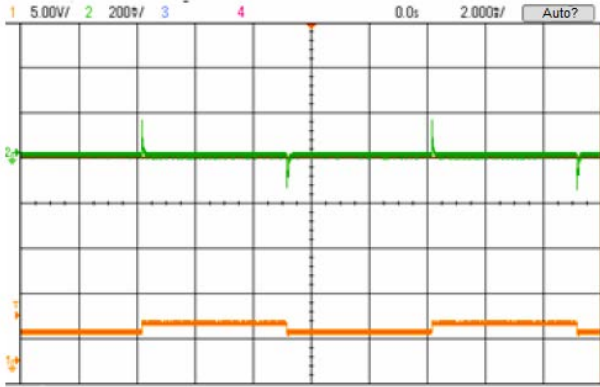

8. Load Transient Response

$V_{IN}=3.3\text{V}$ ,  $I_{OUT}=0.1\text{A}$  to  $1\text{A}$

(Pink:  $I_{OUT}$ , Green:  $V_{OUT}$ )

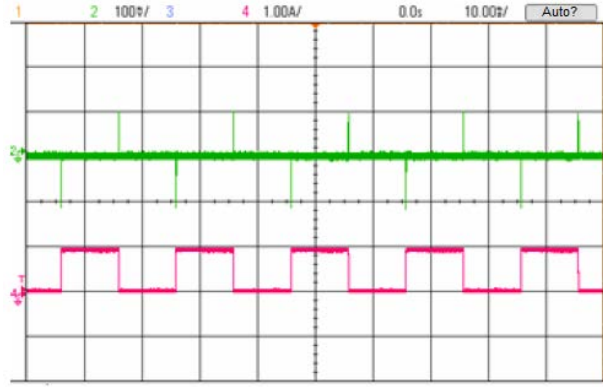



## BLOCK DIAGRAM

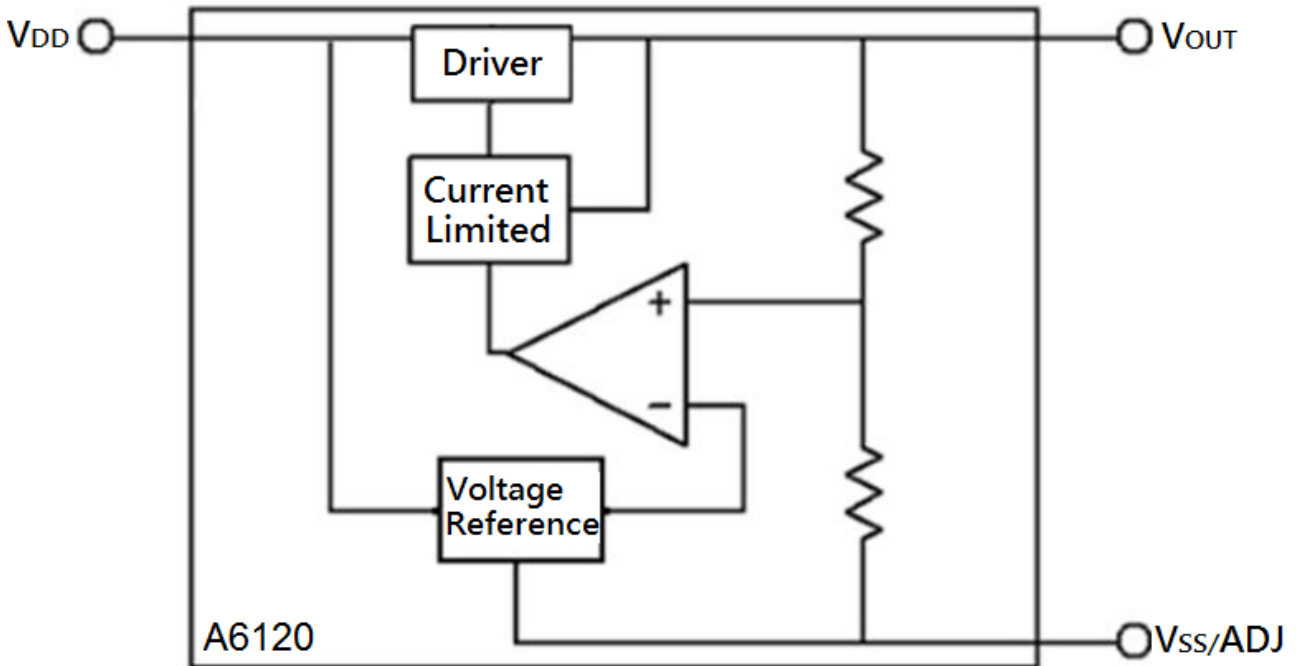

## DETAILED INFORMATION

A6120 is a series of low dropout voltage and low power consumption regulator. Its application circuitry requires minimum number of external components. Both fixed voltage and adjustable voltage application circuits need input and output capacitors to assure output voltage stability. Any desired output voltage from fixed voltage to 18V can be achieved by assigning proper values to two external resistors in its application circuitry (as shown in Fig.2, as R1, R2 are the two external resistors.).

A6120 uses trimming technique to assure the accuracy of output value within  $\pm 2\%$ , at the same time, temperature compensation is elaborately considered in this chip, which makes A6120's temperature coefficient within 100ppm/ $^{\circ}\text{C}$



## TYPICAL APPLICATION

A6120 has fixed voltage and adjustable voltage application mode.

A 1μF ceramic capacitor connected between input and GND as bypass capacitor and a 1μF ceramic capacitor between output and GND are recommended for all application.

Using a bypass capacitor ( $C_{ADJ}$ ) between the adjust terminal and ground can improve ripple rejection. The bypass capacitor prevents ripple from being amplified in case the output voltage is increased. The impedance of  $C_{ADJ}$  should be less than the resistance of R1 to prevent ripple from being amplified at any frequency. As R1 is normally in the range of 1kΩ~10kΩ, the value of  $C_{ADJ}$  should satisfy the following condition:

$$1/(2\pi * \text{Frequency}_{\text{Ripple}} * C_{ADJ}) < R1$$

A 0.1μF ceramic capacitor is recommended.

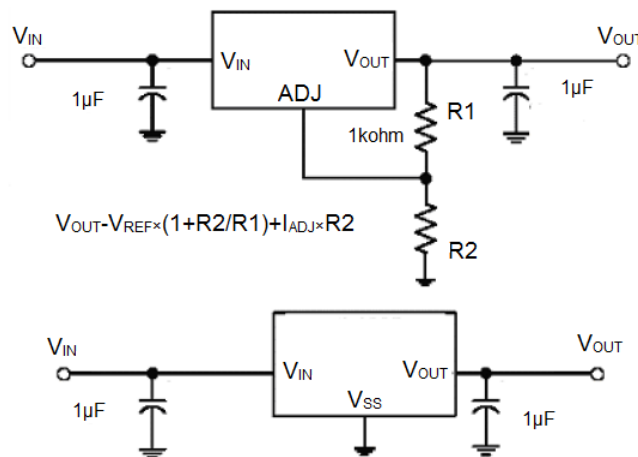

Fig 2. Typical Application of A6120

## EXPLANATION

The output voltage of adjustable application satisfies this followed equation:

$$V_{OUT} = V_{REF} * (1 + R2/R1) + I_{ADJ} * R2.$$

The second term  $I_{ADJ} * R2$  can be ignored since the adjustable pin current  $I_{ADJ}$  (~ 2μA) is much less than the current through R1 (~1mA).

The value of R1 is preferred in the range of 1kΩ ~ 10kΩ and the value of  $V_{REF}$  is the output voltage of typical fixed voltage application circuit.





## PACKAGE INFORMATION

Dimension in SOT-223 (Unit: mm)

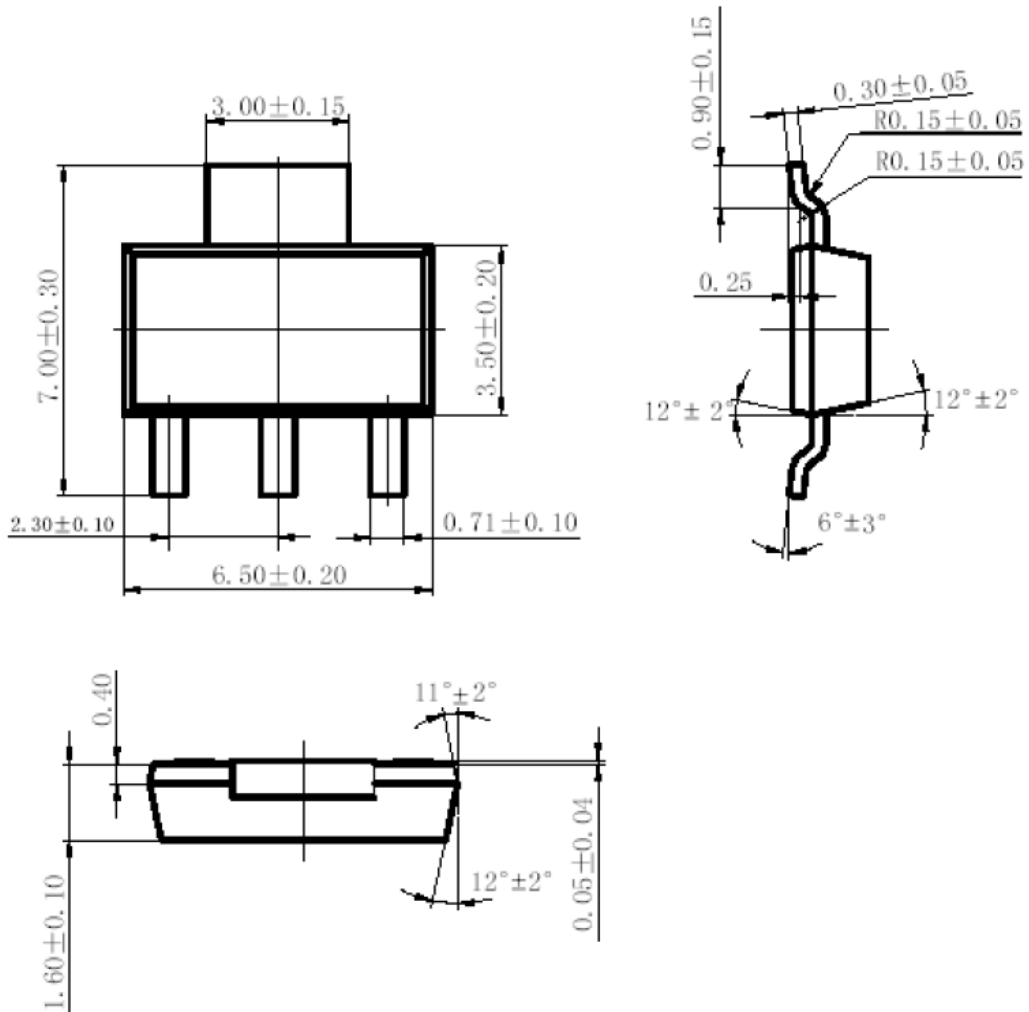



Dimension in TO-252 (Unit: mm)

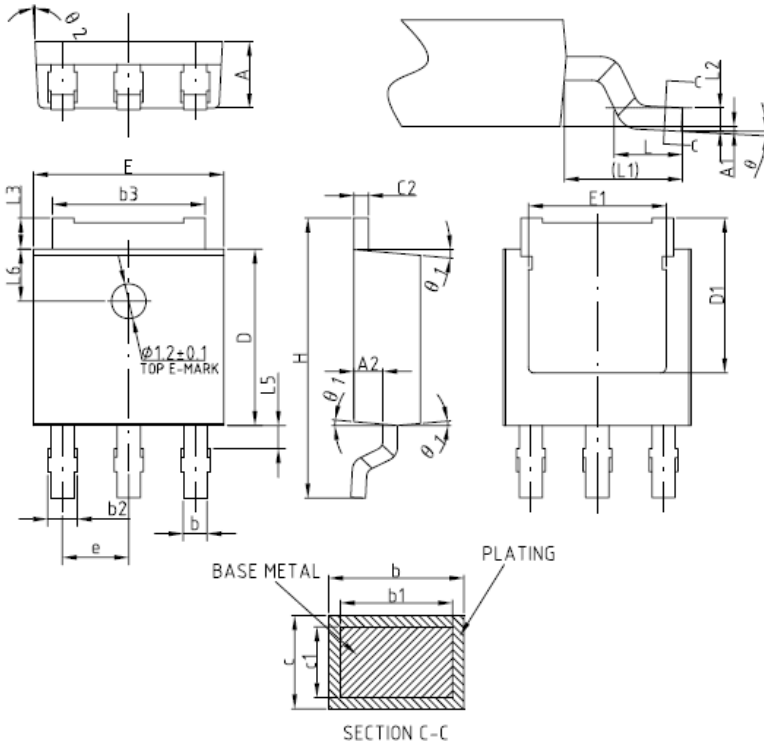

Symbol	Min	Max
A	2.200	2.380
A1	0.000	0.100
A2	0.900	1.100
b	0.770	0.890
b1	0.760	0.860
b2	0.770	1.100
b3	5.230	5.430
c	0.470	0.600
c1	0.460	0.560
c2	0.470	0.600
D	6.000	6.200
D1	5.250	-
E	6.500	6.700
E1	4.700	-
e	2.280(BSC)	
H	9.800	10.40
L	1.400	1.700
L1	2.900(REF)	
L2	0.510(BSC)	
L3	0.900	1.250
L5	0.900	1.500
L6	1.800(REF)	
θ	0°	8°
θ1	3°	7°
θ2	1°	5°



## IMPORTANT NOTICE

AiT Semiconductor Inc. (AiT) reserves the right to make changes to any its product, specifications, to discontinue any integrated circuit product or service without notice, and advises its customers to obtain the latest version of relevant information to verify, before placing orders, that the information being relied on is current.

AiT Semiconductor Inc.'s integrated circuit products are not designed, intended, authorized, or warranted to be suitable for use in life support applications, devices or systems or other critical applications. Use of AiT products in such applications is understood to be fully at the risk of the customer. As used herein may involve potential risks of death, personal injury, or server property, or environmental damage. In order to minimize risks associated with the customer's applications, the customer should provide adequate design and operating safeguards.

AiT Semiconductor Inc. assumes to no liability to customer product design or application support. AiT warrants the performance of its products of the specifications applicable at the time of sale.