

isc Silicon NPN Power Transistor
2SC4762
DESCRIPTION

- High Breakdown Voltage-
: $V_{CBO} = 1500V$ (Min)
- High Switching Speed
- Low Saturation Voltage
- Built-in Damper Diode
- 100% avalanche tested
- Minimum Lot-to-Lot variations for robust device performance and reliable operation

APPLICATIONS

- Horizontal deflection output for medium resolution display.

ABSOLUTE MAXIMUM RATINGS ($T_a = 25^\circ C$)

SYMBOL	PARAMETER	VALUE	UNIT
V_{CBO}	Collector-Base Voltage	1500	V
V_{CEO}	Collector-Emitter Voltage	600	V
V_{EBO}	Emitter-Base Voltage	5	V
I_C	Collector Current- Continuous	± 7	A
I_{CP}	Collector Current-Pulse	± 14	A
I_B	Base Current- Continuous	3.5	A
P_C	Collector Power Dissipation @ $T_c = 25^\circ C$	50	W
T_J	Junction Temperature	150	$^\circ C$
T_{stg}	Storage Temperature Range	-55~150	$^\circ C$

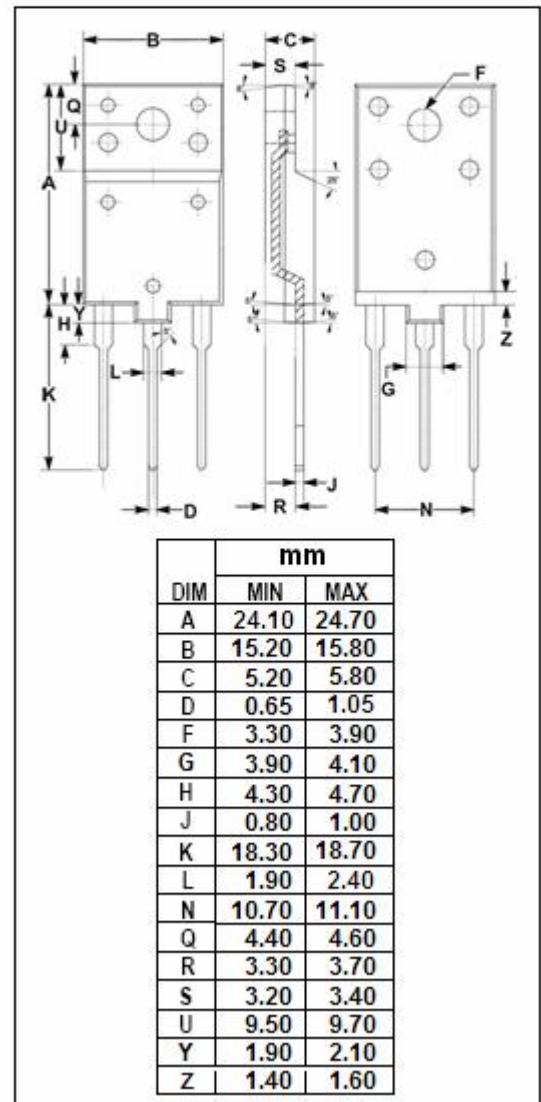
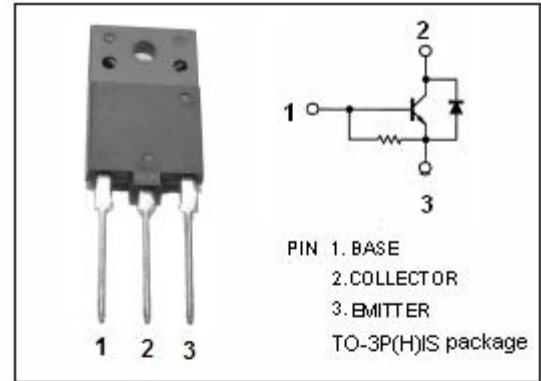

isc Silicon NPN Power Transistor
2SC4762
ELECTRICAL CHARACTERISTICS

 T_c=25°C unless otherwise specified

SYMBOL	PARAMETER	CONDITIONS	MIN	TYP.	MAX	UNIT
V _{(BR)EBO}	Emitter-Base Breakdown Voltage	I _E = 300mA ; I _C = 0	5			V
V _{CE(sat)}	Collector-Emitter Saturation Voltage	I _C = 5A; I _B = 1A			5.0	V
V _{BE(sat)}	Base-Emitter Saturation Voltage	I _C = 5A; I _B = 1A			1.5	V
I _{CBO}	Collector Cutoff Current	V _{CB} = 1500V ; I _E = 0			1.0	mA
I _{EBO}	Emitter Cutoff Current	V _{EB} = 5V ; I _C = 0	83		250	mA
h _{FE-1}	DC Current Gain	I _C = 1A ; V _{CE} = 5V	8			
h _{FE-2}	DC Current Gain	I _C = 5A ; V _{CE} = 5V	5		9	
V _{ECF}	C-E Diode Forward Voltage	I _F = 5A			1.8	V
f _T	Current-Gain—Bandwidth Product	I _C = 0.1A ; V _{CE} = 10V	1	3		MHz
C _{OB}	Output Capacitance	I _E =0 ; V _{CB} =10V; f _{test} =1.0MHz		170		pF

Switching times; Resistive load

t _{stg}	Storage Time	I _C = 5A , I _{B1} = 1A; I _{B2} = -2A R _L = 39 Ω			3.0	μ s
t _f	Fall Time				0.2	μ s

NOTICE:

ISC reserves the rights to make changes of the content herein the datasheet at any time without notification. The information contained herein is presented only as a guide for the applications of our products.

ISC products are intended for usage in general electronic equipment. The products are not designed for use in equipment which require specialized quality and/or reliability, or in equipment which could have applications in hazardous environments, aerospace industry, or medical field. Please contact us if you intend our products to be used in these special applications.

ISC makes no warranty or guarantee regarding the suitability of its products for any particular purpose, nor does ISC assume any liability arising from the application or use of any products, and specifically disclaims any and all liability, including without limitation special, consequential or incidental damages.